

Lens Controller Series

Rev 2.0



The AFZ Lens Controller Unit provides precise control over zoom, focus, and iris settings for compatible lenses. This unit simplifies lens operation through a user-friendly interface and eliminates the need for manual adjustments. The AFZ also offers advanced features, such as programmable presets and seamless integration with external applications via a dedicated API.

Technical specifications

Power requirements	24Vdc 1A	
Input options	USB-C (USB to UART chip) RS232 5-24V Preset Inputs (4x)	
Housing	Metal	
Operating environment	Temperature	0~40 °C
	Humidity	20~85 %
Certification	CE / RoHS	
Accessories	VA0-LC1-CBL2	2 meter lens connection cable
	VA0-LC1-CBL5	5 meter lens connection cable

The information provided in this documentation contains general descriptions and/or technical characteristics of the performance of the products contained herein. This documentation is not intended as a substituted for and is not to be used for determining suitability or reliability of these products for specific user applications. It is the duty of any such user or integrator to perform the appropriate and complete risk analysis, evaluation, and testing of the products with respect to the relevant specific application or use thereof. Neither VA Imaging nor any of its affiliates or subsidiaries shall be responsible or liable for misuse of the information contained herein or incorrect information in this document.

Lens Options

	VA7-LCM-12MP-1040MM-F1.6-100-AFZ	VA7-LCS-12MP-1050MM-F1.4-017-AFZ
Focal Length (mm)	10-40	10-50
Mount	C	CS
Sensor size	1"	1/1.7"
Resolution (megapixels)	12	12
Aperture	F1.6	F1.4
IR Corrected	Yes	Yes
Distortion	-8% ~ -4.8%	-10.7% ~ 0.07%
Minimum object distance (m)	2.5	1.5
Dimensions (mm)	Ø66 x 98.07	Ø50 x 87.4
Weight (gram)	560	265

Technical drawing

Controller

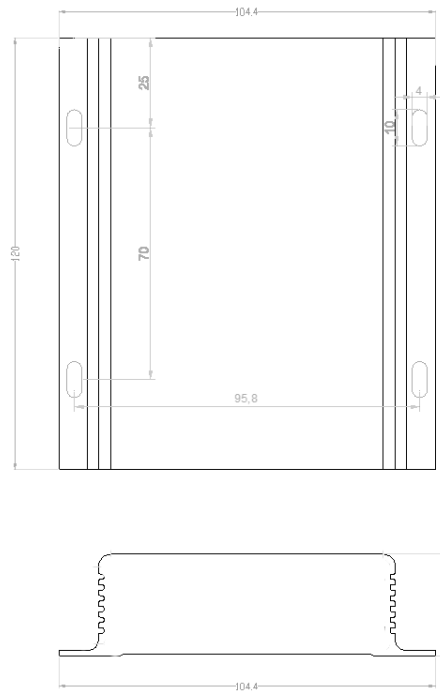

The information provided in this documentation contains general descriptions and/or technical characteristics of the performance of the products contained herein.

This documentation is not intended as a substituted for and is not to be used for determining suitability or reliability of these products for specific user applications.

It is the duty of any such user or integrator to perform the appropriate and complete risk analysis, evaluation, and testing of the products with respect to the relevant specific application or use thereof. Neither VA Imaging nor any of its affiliates or subsidiaries shall be responsible or liable for misuse of the information contained herein or incorrect information in this document.

VA7-LCM-12MP-1040MM-F1.6-100-AFZ

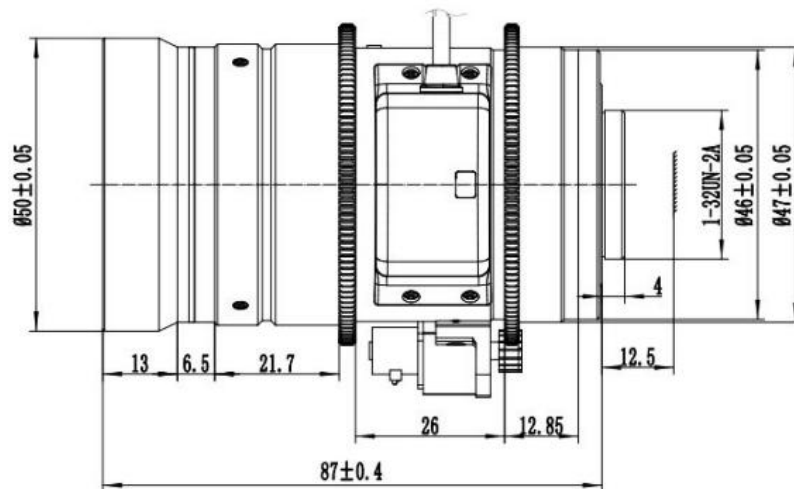
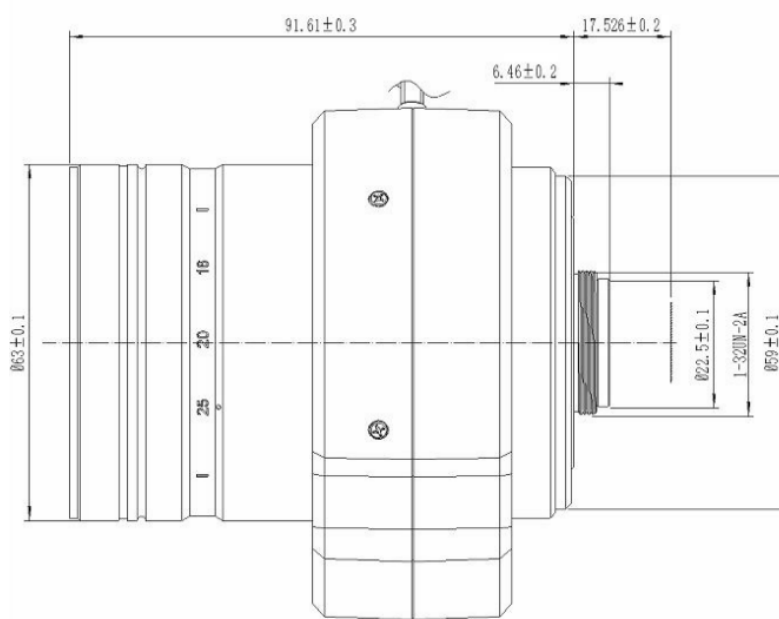

The information provided in this documentation contains general descriptions and/or technical characteristics of the performance of the products contained herein.

This documentation is not intended as a substituted for and is not to be used for determining suitability or reliability of these products for specific user applications.

It is the duty of any such user or integrator to perform the appropriate and complete risk analysis, evaluation, and testing of the products with respect to the relevant specific application or use thereof. Neither VA Imaging nor any of its affiliates or subsidiaries shall be responsible or liable for misuse of the information contained herein or incorrect information in this document.

Usage

The lens controller has an internal positioning system. By calibrating the lens controller, the positioning system is calibrated and the system will know the position of each motor at all times. The positioning system is used for setting and calling presets and for moving to a specific position. The unit can be configured that during startup the calibration sequence is automatically started, but can also be done with the API. There are a few options to use controller:

1. RS-232 Input
2. USB-C Input
3. 4 Input presets

The RS-232 and USB connection cannot be active at the same time. The selection of the connection used is done by setting dipswitch 2: Down = USB / Up = RS-232

The RS-232 port settings are: 19200,8,N,1, 10 sec timeout. When connecting the controller to a PC via the USB port, a virtual comport is created and the port settings are the same.

RS-232 Pelco-D

When using the lens controller with RS-232, the Pelco-D protocol can be used with the following command sequence:

Byte 1	Byte 2	Byte 3	Byte 4	Byte 5	Byte 6	Byte 7
0xFF	0x01	Command 1	Command 2	0x00	Data	Checksum

The check sum is the 8-bit (modulo 256) sum of the payload (bytes 2 through 6) in the message. Commands are and data values are according to the table below:

Function	Command 1	Command 2	Data
Zoom In	0x00	0x20	0x00
Zoom Out	0x00	0x40	0x00
Focus Near	0x01	0x00	0x00
Focus Far	0x00	0x80	0x00
Iris Open	0x02	0x00	0x00
Iris Close	0x04	0x00	0x00
Call Preset	0x00	0x07	Preset [1-10]
Set Preset	0x00	0x03	Preset [1-10]
Set Zoom Speed	0x00	0x25	Speed [0-2]
Set Focus Speed	0x00	0x27	Speed [0-2]
Stop all motors	0x00	0x00	0x00

Windows Application

Connect the board to your PC via USB for control and preset saving through a downloadable application. This software unlocks full lens control and easy switching between saved preset.

A. Connecting to the controller

1. After running the application, the Controller Type = AFZ Controller, Serial port = COMx. Where x is the port assigned to the board by windows.

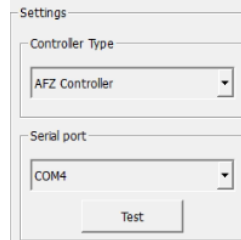

Click on "Test", when the board is successfully connected the following message is displayed:

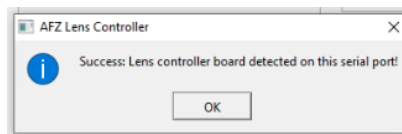

When a error message is displayed try the following:

- Try selecting another Serial port from the list
 - Check the controller has power connected
2. After connecting to the board, selecting the connected lens:

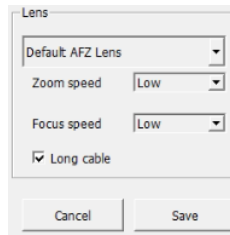

3. Select the zoom and focus speed; A higher settings will increase the time to adjust but will be less accurate.
4. When the cable connected is longer than 5 meter, enable the "Long cable" option. This will make the calibration less sensitive to noise.
5. Press save to store the settings to the controller and enable control.

B. Controlling the lens.

1. The lens can be controlled with the section below.

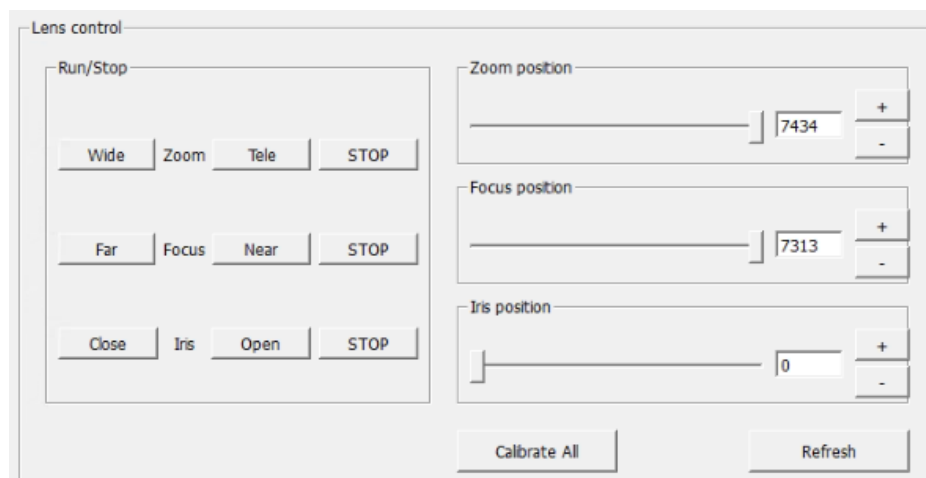

2. The calibration sequence can also be started with the button "Calibrate all"
3. The current position can be loaded from the controller by pressing "Refresh"

C. Setting presets

1. 10 Positions can be saved and stored in the controller by using the panel below:

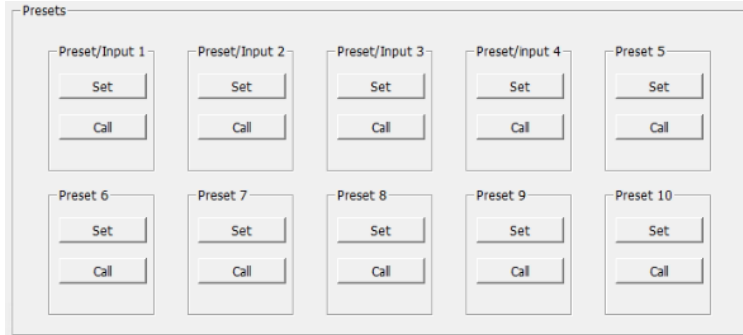

2. The values can be written to the controller with the "Store in device" button.



3. These positions can later be called by the Software, API or by RS-232. The first 4 presets can also be loaded with the hardware preset inputs.

API

A Python API facilitates seamless integration of the controller into various applications. This API not only enables control but also expands Pelco-D functionality by introducing absolute position control. Comprehensive documentation for these commands accompanies the API for ease of use.

Input Presets

The device supports storing preset positions for focus, zoom, and iris. These settings can be saved to the device's internal memory using either the provided API or the Windows application. Activation of a preset occurs upon receiving a rising edge signal on the designated input.

Example usage

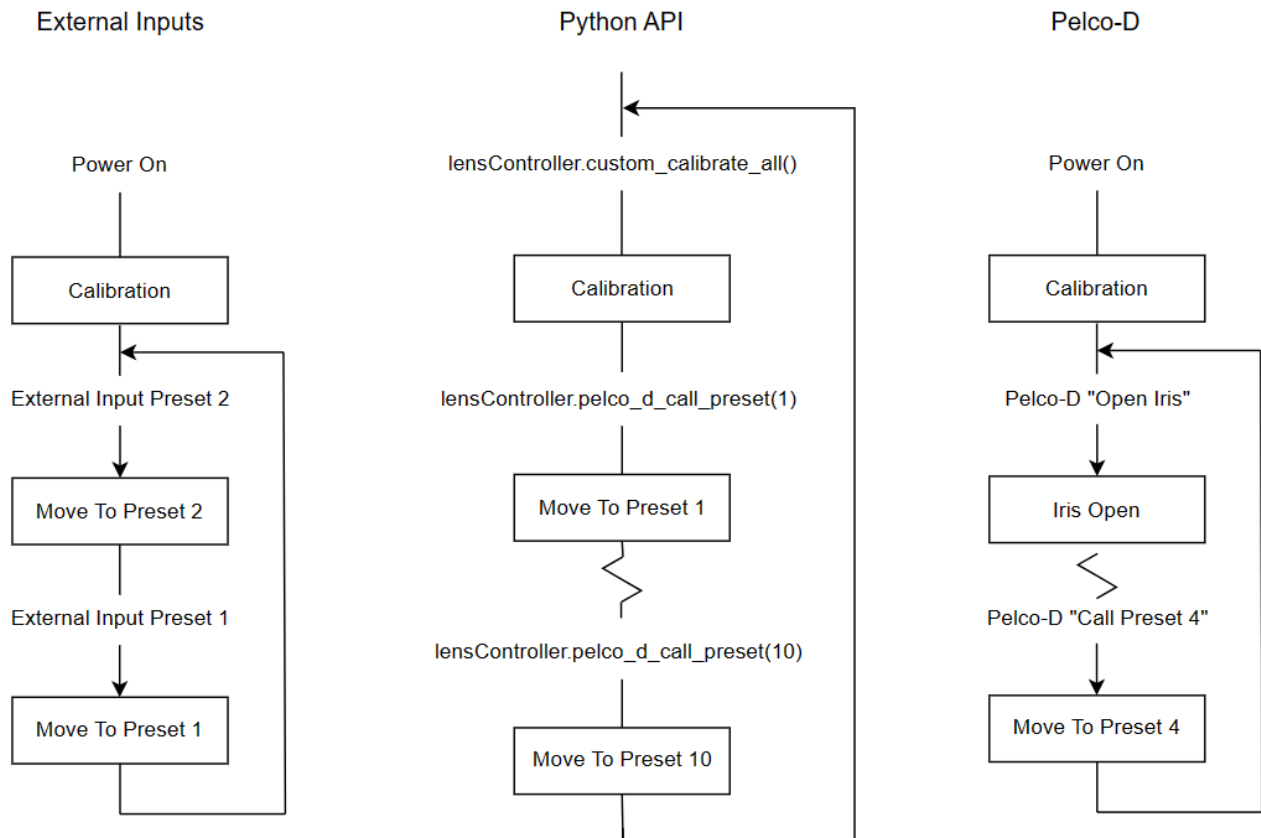

Motor cable

Pin	Color	Function	VA7-LCS-10MP-1050MM-F1.4-017-AFZ Internal Color	VA7-LCM-12MP-1040MM-F1.6-100-AFZ Internal Color
1	Green	Focus A	Red	Black
2	Blue	Focus A-	Yellow	White
3	Grey	Focus B	Brown	Blue
4	Purple	Focus B-	Orange	Red
5	Orange	Zoom A	Red	Yellow
6	Pink	Zoom A-	Yellow	Green
7	White/Green	Zoom B	Brown	Purple
8	White/Blue	Zoom B-	Orange	Orange
9	White/Grey	Iris A	Red	Red
10	White/Purple	Iris A-	Yellow	Yellow
11	White/Orange	Iris B	Brown	Brown
12	White/Pink	Iris B-	Orange	Orange

DIP Switch

Pin	Function
1	ON = Calibration on power up active
2	USB / RS-232 Selection

RS-232

Pin	Function
1	TX
2	RX
3	GND

Input preset

