

China Daheng Group, Inc. Beijing Image Vision Technology Branch

# MERCURY USB3 Vision Cameras

## User Manual

Version: V1.0.54  
Date: 2020-03-09

**D HENG** | **大恒图像**  
**IM GING**

All rights reserved. No parts of this manual may be used or reproduced, in any forms or by any means, without prior written permission of China Daheng Group, Inc. Beijing Image Vision Technology Branch.

The right is also reserved to modify or change any parts of this manual in the future without prior notification.

All other trademarks are the properties of their respective owners.

© 2020 China Daheng Group, Inc. Beijing Image Vision Technology Branch

Web: <http://www.daheng-imaging.com/en>

Sales Email: [isales@daheng-imaging.com](mailto:isales@daheng-imaging.com)

Sales Tel: +86 10 8282 8878

Support Email: [isupport@daheng-imaging.com](mailto:isupport@daheng-imaging.com)

# Preface

We really appreciate your choosing of DAHENG IMAGING products.

The MERCURY USB3.0 series camera is DAHENG IMAGING's mature area scan industrial digital camera, featuring high resolution, high definition and extremely low noise. The camera is equipped with standard USB3.0 interface, is easy to install and use.

The MERCURY family cameras are especially suitable for machine vision applications such as industrial inspection, medical, scientific research, education, security and so on.

The MERCURY USB3 Vision series camera is a compact camera that will be a good choice for the users who are demanding on the camera size. This manual describes in detail on how to install and use the MERCURY USB3 Vision digital cameras.

# Contents

<b>1. Introduction</b>	<b>1</b>
1.1. Series Introduction	1
1.2. Naming Rules	1
1.3. Standards	2
1.4. Document, CAD/Technical Drawing and Software Downloads	2
<b>2. Precautions</b>	<b>3</b>
2.1. Guideline for Avoiding EMI and ESD	3
2.2. Environmental Requirements	3
2.3. Camera Mechanical Installation Precautions	3
<b>3. Installation Guideline</b>	<b>4</b>
3.1. Host Preparation	4
3.1.1. Software Package	4
3.1.2. User Software Interface	4
3.2. Camera Power	5
3.3. Camera Driver Installation	6
3.3.1. System Requirements	6
3.3.2. Driver Installation	6
3.4. Open Device and Start Acquisition	6
<b>4. General Specification</b>	<b>7</b>
4.1. Explanation of Important Parameters	7
4.1.1. About Spectral Response	7
4.2. MER-031-860U3M/C(-L)	7
4.2.1. Parameter	7
4.2.2. Spectral Response	10
4.3. MER-031-860U3M(-L) NIR	11
4.3.1. Parameter	11
4.3.2. Spectral Response	12
4.4. MER-041-436U3M/C(-L)	12
4.4.1. Parameter	12
4.4.2. Spectral Response	15
4.5. MER-050-560U3M/C(-L)	15
4.5.1. Parameter	15
4.5.2. Spectral Response	18
4.6. MER-050-560U3M(-L) NIR	18
4.6.1. Parameter	18
4.6.2. Spectral Response	19
4.7. MER-051-120U3M/C(-L)	19

4.7.1. Parameter .....	19
4.7.2. Spectral Response.....	22
4.8. MER-131-210U3M/C(-L) .....	22
4.8.1. Parameter .....	22
4.8.2. Spectral Response.....	24
4.9. MER-131-210U3M(-L) NIR.....	25
4.9.1. Parameter .....	25
4.9.2. Spectral Response.....	26
4.10. MER-132-43U3M/C(-L) .....	26
4.10.1. Parameter .....	26
4.10.2. Spectral Response.....	29
4.11. MER-131-210U3M/C(-L).....	30
4.11.1. Parameter.....	30
4.11.2. Spectral Response .....	32
4.12. MER-134-93U3M/C(-L) .....	33
4.12.1. Parameter .....	33
4.12.2. Spectral Response.....	36
4.13. MER-160-227U3M/C(-L) .....	36
4.13.1. Parameter .....	36
4.13.2. Spectral Response.....	39
4.14. MER-230-168U3M/C(-L) .....	39
4.14.1. Parameter .....	39
4.14.2. Spectral Response.....	42
4.15. MER-231-41U3M/C(-L) .....	43
4.15.1. Parameter .....	43
4.15.2. Spectral Response.....	46
4.16. MER-301-125U3M/C(-L) .....	47
4.16.1. Parameter .....	47
4.16.2. Spectral Response.....	49
4.17. MER-302-56U3M/C(-L) .....	50
4.17.1. Parameter .....	50
4.17.2. Spectral Response.....	53
4.18. MER-500-14U3M/C(-L) .....	53
4.18.1. Parameter .....	53
4.18.2. Spectral Response.....	56
4.19. MER-502-79U3M/C(-L) .....	57
4.19.1. Parameter .....	57
4.19.2. Spectral Response.....	60
4.20. MER-502-79U3M(-L) POL.....	61
4.20.1. Parameter .....	61
4.20.2. Spectral Response.....	62
4.21. MER-503-36U3M/C(-L) .....	62

4.21.1. Parameter .....	62
4.21.2. Spectral Response.....	65
4.22. MER-630-60U3M/C(-L) .....	66
4.22.1. Parameter .....	66
4.22.2. Spectral Response.....	68
4.23. MER-1070-14U3M/C(-L) .....	69
4.23.1. Parameter .....	69
4.23.2. Spectral Response.....	72
4.24. MER-1220-32U3M/C(-L) .....	73
4.24.1. Parameter .....	73
4.24.2. Spectral Response.....	75
4.25. MER-1520-13U3C(-L) .....	76
4.25.1. Parameter .....	76
4.25.2. Spectral Response.....	78
4.26. MER-1810-21U3C(-L) .....	78
4.26.1. Parameter .....	78
4.26.2. Spectral Response.....	80
4.27. MER-2000-19U3M/C(-L) .....	80
4.27.1. Parameter .....	80
4.27.2. Spectral Response.....	83
<b>5. Dimensions .....</b>	<b>84</b>
5.1. Camera Dimensions.....	84
5.2. Optical Interface .....	85
5.3. Tripod Adapter Dimensions .....	85
<b>6. Filters and Lenses .....</b>	<b>87</b>
6.1. Filters .....	87
6.2. Lens Selection Reference .....	88
6.2.1. HN-2M Series .....	89
6.2.2. HN-5M Series .....	89
<b>7. Electrical Interface.....</b>	<b>91</b>
7.1. LED Light.....	91
7.2. USB Port .....	91
7.3. I/O Port.....	91
7.3.1. Line0 (Opto-isolated Input) Circuit .....	92
7.3.2. Line1 (Opto-isolated Output) Circuit.....	93
7.3.3. Line 2/Line3 (Bidirectional) Circuit.....	95
7.3.3.1. Line2/3 is Configured as Input.....	96
7.3.3.2. Line2/3 is Configured as Output .....	97
<b>8. Features.....</b>	<b>100</b>
8.1. I/O Control .....	100

8.1.1. Input Mode Operation .....	100
8.1.2. Output Mode Operation.....	101
8.1.3. Read the LineStatus.....	102
<b>8.2. Image Acquisition Control.....</b>	<b>103</b>
8.2.1. Acquisition Start and Stop .....	103
8.2.1.1. Acquisition Start.....	103
8.2.1.2. Acquisition Stop.....	104
8.2.2. RegionSendMode .....	105
8.2.2.1. Single ROI mode and Configuration .....	106
8.2.2.2. Multi-ROI mode and Configuration .....	106
8.2.3. Switching Acquisition Mode.....	107
8.2.4. Continuous Mode and Configuration.....	109
8.2.5. Software Trigger Acquisition and Configuration .....	109
8.2.6. External Trigger Acquisition and Configuration .....	110
8.2.7. Set Exposure .....	112
8.2.8. Overlapping Exposure and Non-overlapping Exposure .....	115
8.2.9. Strobe .....	117
<b>8.3. Basic Features .....</b>	<b>119</b>
8.3.1. Gain .....	119
8.3.2. Pixel Format.....	121
8.3.3. ROI.....	124
8.3.4. Auto Exposure/Auto Gain.....	125
8.3.4.1. ROI Setting of Auto Exposure/Auto Gain.....	125
8.3.4.2. Auto Gain.....	126
8.3.4.3. Auto Exposure .....	127
8.3.5. Auto White Balance.....	127
8.3.5.1. Auto White Balance ROI.....	127
8.3.5.2. Auto White Balance Adjustment.....	128
8.3.6. Test Pattern .....	129
8.3.7. User Set Control .....	130
8.3.8. Device User ID.....	133
8.3.9. Timestamp .....	133
8.3.10. Binning .....	133
8.3.11. Decimation .....	136
8.3.12. Reverse X and Reverse Y.....	138
8.3.13. User Data Area .....	140
8.3.14. Timer .....	140
8.3.15. Counter .....	142
<b>8.4. Image Processing.....</b>	<b>142</b>
8.4.1. Defect Pixel Correction .....	142
<b>8.5. Image Transmission .....</b>	<b>143</b>
8.5.1. Calculate Frame Rate .....	143

8.5.2. USB Interface Bandwidth .....	144
8.5.3. DeviceLinkThroughputLimit.....	144
8.5.4. Camera Acquisition Time .....	147
<b>9. Software Tool .....</b>	<b>153</b>
9.1. Frame Rate Calculation Tool .....	153
<b>10. FAQ .....</b>	<b>155</b>
<b>11. Revision History .....</b>	<b>157</b>
<b>12. Contact Us.....</b>	<b>160</b>
12.1. Contact Sales .....	160
12.2. Contact Support .....	161



# 1. Introduction

## 1.1. Series Introduction

The MER-U3 and MER-U3-L cameras of MERCURY USB3 Vision series are DAHENG IMAGING's mature area scan industrial digital camera, featuring outstanding performance, compact size, outstanding price/performance ratio, which are easy to install and use. The MER-U3 series camera integrates I/O (GPIO) interfaces to provide external power supply and various control operations such as external trigger and strobe. Compared to the MER-U3 series, the MER-U3-L series camera has no I/O (GPIO) interfaces, so it is lighter and more cost effective. The MER-U3 and MER-U3-L series cameras are available in a variety of resolutions and frame rates, and are available with CCD and CMOS sensors from leading chip manufacturers.

The MER-U3 and MER-U3-L series digital cameras transmit image data through the USB3.0 data interface. Thanks to the locking screw connectors, the MERCURY series cameras can secure the reliability of cameras deployed in harsh industrial environments. Featuring high reliability and high price/performance ratio, the MERCURY series cameras are especially suitable for machine vision applications such as industrial inspection, medical, scientific research, education, security and so on. And the MERCURY USB3 Vision series camera will be a good choice for the users who are demanding on the camera size.

## 1.2. Naming Rules

Details of the MERCURY USB3 Vision series camera are given in the [section 4](#). Each camera model name is determined by its sensor's maximum resolution, maximum frame rate at maximum resolution, the color/monochrome type of the sensor, and whether external trigger interfaces are provided, etc.

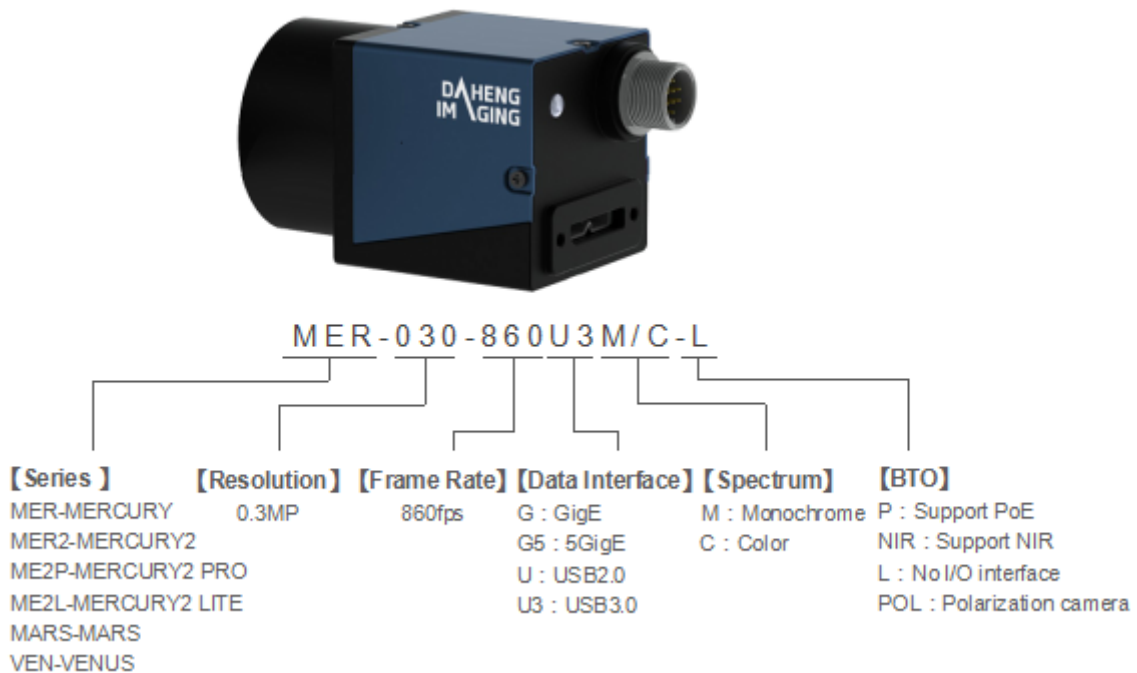

Figure 1-1 Naming rules

### 1.3. Standards

The camera follows the USB3 Vision1.0 standard, and its development interface GalaxySDK is implemented based on the GEN<i>CAM standard.

### 1.4. Document, CAD/Technical Drawing and Software Downloads

Product related document, CAD/Technical drawing and software can be downloaded from the [Downloads](#) of DAHENG IMAGING website. The relevant contents are as follows:

Document	MERCURY USB3 Vision Cameras User Manual
CAD/Technical Drawing	DAHENG IMAGING MER-U3 CAD/Technical Drawing
Software	Galaxy Windows SDK—USB3.0, GigE, MERCURY USB2.0 Cameras
	Galaxy Linux SDK—USB3.0, GigE, MERCURY USB2.0 Cameras

## 2. Precautions

### 2.1. Guideline for Avoiding EMI and ESD

You should consider the EMI (Electro Magnetic Interference) and ESD (Electro-Static Discharge) problem in the process of using the camera, to guarantee the camera to work in a relatively good electromagnetic environment. The main measures are as follows:

- 1) USB cables certificated by USB IF with locking screw are recommended.
- 2) Using shielded cable can avoid electro-magnetic interface. Shielding layer of the cable should conduct to ground nearby and not until stretched too long. When many devices need conduct to ground, using single point grounding to avoid earth loop.
- 3) Keep your cameras away from equipment with high voltage, or high current (such as motor, inverter, relay, etc.). If necessary, use additional shielding.
- 4) ESD (electro-static discharge) may damage cameras permanently, so use suitable clothing (cotton) and shoes, and touch the metal to discharge the electro-static before operating cameras.

### 2.2. Environmental Requirements

- 1) Housing temperature during operation: 0°C ~ 45°C, humidity during operation: 10% ~ 80%.  
Storage temperature: -20°C ~ 70°C.
- 2) To avoid collecting dust in the optical filter, always keep the plastic cap on cameras when no lens is mounted.
- 3) PC requirement: Intel Core 2 Duo, 2.4GHz or above, and 2GB memory or above.
- 4) USB3.0 host controller requirement: Intel controller integrated in mainboard is recommend. Select Renesas controller if external frame grabber is needed.
- 5) The cable must have a locking screw at the end of the device.
- 6) Make sure that cameras are transported in the original factory packages.

### 2.3. Camera Mechanical Installation Precautions

Camera installation requirements:

- 1) The screw and camera have a screw length between 2.5 and 2.7mm.
- 2) Screw assembly torque  $\leq 1\text{N.M}$ . If the screw assembly torque is too large, it may cause the camera thread stripping.

## 3. Installation Guideline

### 3.1. Host Preparation

#### 3.1.1. Software Package

The software package of DAHENG IMAGING's MERCURY series is used to control the MERCURY series camera to provide stable, real-time image transmission, and provides multiple samples and easy-to-integrate SDKs for various programming tools. The package is composed of the following modules:

- 1) Driver Package (Driver): This package provides the MERCURY series camera driver program, such as: the USB3.0 cameras' driver program.
- 2) Interface Library (API): This package provides the camera control interface library and the image processing interface library, supports the user for secondary development.
- 3) Demonstration Program (GalaxyView.exe): This demonstration program is used to display the camera control, image acquisition and image processing functions, the user can control the camera directly by the demonstration program, and the user can develop their own control program based on the camera interface library.
- 4) Sample: These samples demonstrate cameras' functions, the user can easily use these samples to control cameras, or refer to the samples to develop their own control programs.
- 5) Programmer's Manual: This manual is the users programming guide that instructs the users how to configure the programming environment and how to control cameras and acquire images through the camera interface library.

You can download the latest software package from the website: [www.daheng-imaging.com/en/Downloads](http://www.daheng-imaging.com/en/Downloads).

#### 3.1.2. User Software Interface

After installing the MERCURY series camera software package, the user can use the demonstration program and the samples to control the camera, also the user can control the camera by the program which is written by the user themselves. The software package provides three kinds of program interface, the user can select the suitable one for use according to their own requirements:

##### 1) API Interface

In order to simplify the users' programming complexity, the package provides the general C programming interface GxIAPI.dll and image processing algorithm interface DxImageProc.dll for the user to control the camera, and provides the samples and software development manual which are based on these interfaces. The API interface supports C/C++/C#/Python, etc.

##### 2) GenTL Interface

This interface is developed according to the standard of general transport layer in GEN<i>CAM standard, DAHENG IMAGING follows the GEN<i>CAM standard and provides the GenTL interface for the user, the

user can use the GenTL interface directly to develop their own control program. The definition and usage of GenTL interfaces can be downloaded from the website of EMVA.

In addition, users can use some third-party software that supports GEN<i>CAM standard to control the camera, such as HALCON.

### 3) USB3 Vision interface

The MERCURY series USB3.0 camera is compatible with the USB3 Vision protocol, which allows the user to control the camera directly through the USB3 Vision protocol. In addition, the user can use some third-party software that supports the USB3 Vision protocol to control the camera, such as HALCON.

#### ● Note

GEN<i>CAM standard: GEN<i>CAM is administered by the European Machine Vision Association (EMVA). GenICam provides a generic programming interface for all kinds of cameras and devices. It provides a standard application programming interface (API), no matter what interface technology is being used. It mainly includes the following modules:

- GenAPI: an XML description file format defining how to capture the features of a device and how to access and control these features in a standard way
- GenTL: a generic Transport Layer Interface, between software drivers and libraries, that transports the image data from the camera to the application running on a PC
- SFNC: common naming convention for camera features, which promotes interoperability between products from different manufacturers

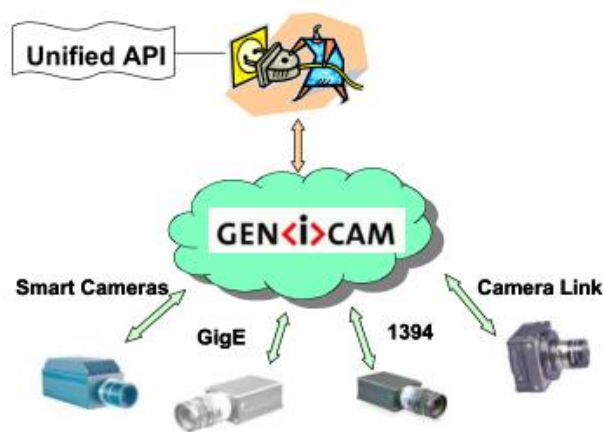

Figure 3-1 GEN<i>CAM standard schematic diagram

## 3.2. Camera Power

The camera is powered by the USB 3.0 interface.

### 3.3. Camera Driver Installation

#### 3.3.1. System Requirements

GalaxySDK is suitable for all cameras in the MERCURY series. The GalaxySDK contains various operating systems such as Windows, Android and Linux. The requirements for the operating system and version of the installation package are as follows:

Operating Systems	Applicable Version
Windows	<ul style="list-style-type: none"><li>➤ Windows XP (32bit, 64bit)</li><li>➤ Windows 7 (32bit, 64bit)</li><li>➤ Windows 8 (32bit, 64bit)</li><li>➤ Windows 8.1 (32bit, 64bit)</li><li>➤ Windows 10 (32bit, 64bit)</li></ul>
Linux	<ul style="list-style-type: none"><li>➤ Ubuntu 12.04 or above, kernel version 3.5.0.23 or above</li></ul>
Android	<ul style="list-style-type: none"><li>➤ Android6 or above</li></ul>

#### 3.3.2. Driver Installation



The steps to install the Galaxy SDK under Windows are as follows:

- 1) Download the corresponding version of the installation package from [www.daheng-imaging.com/en/Downloads](http://www.daheng-imaging.com/en/Downloads).
- 2) Run the installer.
- 3) Follow the instructions of the installation wizard to complete the installation process. During the installation process, you can choose the camera interface you need (USB2.0, USB3 Vision, GigE Vision, etc.).

During the installation process, especially when installing the \*.sys file, you must always pay attention to whether the anti-virus software intercepts the driver. If intercepted, it may cause the driver installation to fail.

### 3.4. Open Device and Start Acquisition

After powering the device, connecting the device to the USB3.0 interface of the host. Double-click the GalaxyView software to acquire image. The steps are as follows:

- 1) Click the  icon on the toolbar in the GalaxyView to refresh device list.
- 2) After the device is enumerated, double-click the device enumerated in the device list.
- 3) Click the  icon on the toolbar to perform the Start Acquisition operation on the current device.

## 4. General Specification

### 4.1. Explanation of Important Parameters

#### 4.1.1. About Spectral Response

QE: Quantum efficiency, which is the ratio of the average number of photoelectrons produced per unit time to the number of incident photons at a given wavelength.

Sensitivity: The change of the sensor output signal relative to the incident light energy. The commonly used sensitivity units are  $V/((W/m^2)\cdot s)$ ,  $V/lux\cdot s$ ,  $e-/((W/m^2)\cdot s)$  or  $DN/((W/m^2)\cdot s)$ .

The spectral response graphs given by different manufacturers are different. Some graphs' ordinate is relative sensitivity response, and abscissa is wavelength. Some graphs' ordinate is QE, and abscissa is wavelength.

### 4.2. MER-031-860U3M/C(-L)

#### 4.2.1. Parameter

Specifications	MER-031-860U3C	MER-031-860U3C-L
Resolution	640×480	
Sensor Type	Onsemi PYTHON 300 global shutter CMOS	
Optical Size	1/4 inch	
Pixel Size	4.8μm×4.8μm	
Frame Rate	860fps @ 640×480	
ADC Bit Depth	10bit	
Pixel Bit Depth	8bit, 10bit	
Shutter Time	20μs~1s	
Gain	0dB~16dB	
Pixel Data Formats	Bayer RG8/Bayer RG10	
Signal Noise Ratio	37.84dB	
Synchronization	External trigger, software trigger	Software trigger

I/O	1 input and 1 output with opto-isolated, 2 programmable GPIOs	N/A
Operating Temp.	0°C~45°C	
Storage Temp.	-20°C~70°C	
Operating Humidity	10%~80%	
Power Consumption	< 2.7W@5V	
Lens Mount	C	
Dimensions	29mm×29 mm×29mm (without lens adapter or connectors)	
Weight	57g	53g
Software	Windows XP/Win7/Win8/Win10 32bit, 64bit OS	
Data Interface	USB3.0	
Programmable Control	Image size, gain, exposure time, trigger polarity, flash polarity	Image size, gain, exposure time
Conformity	CE, RoHS, FCC, USB3 Vision, GenICam	

Table 4-1 MER-031-860U3C(-L) camera specifications

Specifications	MER-031-860U3M	MER-031-860U3M-L
Resolution	640×480	
Sensor Type	Onsemi PYTHON 300 global shutter CMOS	
Optical Size	1/4 inch	
Pixel Size	4.8μm×4.8μm	
Frame Rate	860fps @ 640×480	
ADC Bit Depth	10bit	
Pixel Bit Depth	8bit, 10bit	
Shutter Time	20μs~1s	



Gain	0dB~16dB	
Pixel Data Formats	Mono8/Mono10	
Signal Noise Ratio	38dB	
Synchronization	External trigger, software trigger	Software trigger
I/O	1 input and 1 output with opto-isolated, 2 programmable GPIOs	N/A
Operating Temp.	0°C~45°C	
Storage Temp.	-20°C~70°C	
Operating Humidity	10%~80%	
Power Consumption	< 2.7W@5V	
Lens Mount	C	
Dimensions	29mm×29 mm×29mm (without lens adapter or connectors)	
Weight	57g	53g
Software	Windows XP/Win7/Win8/Win10 32bit, 64bit OS	
Data Interface	USB3.0	
Programmable Control	Image size, gain, exposure time, trigger polarity, flash polarity	Image size, gain, exposure time
Conformity	CE, RoHS, FCC, USB3 Vision, GenICam	

Table 4-2 MER-031-860U3M(-L) camera specifications

4.2.2. Spectral Response

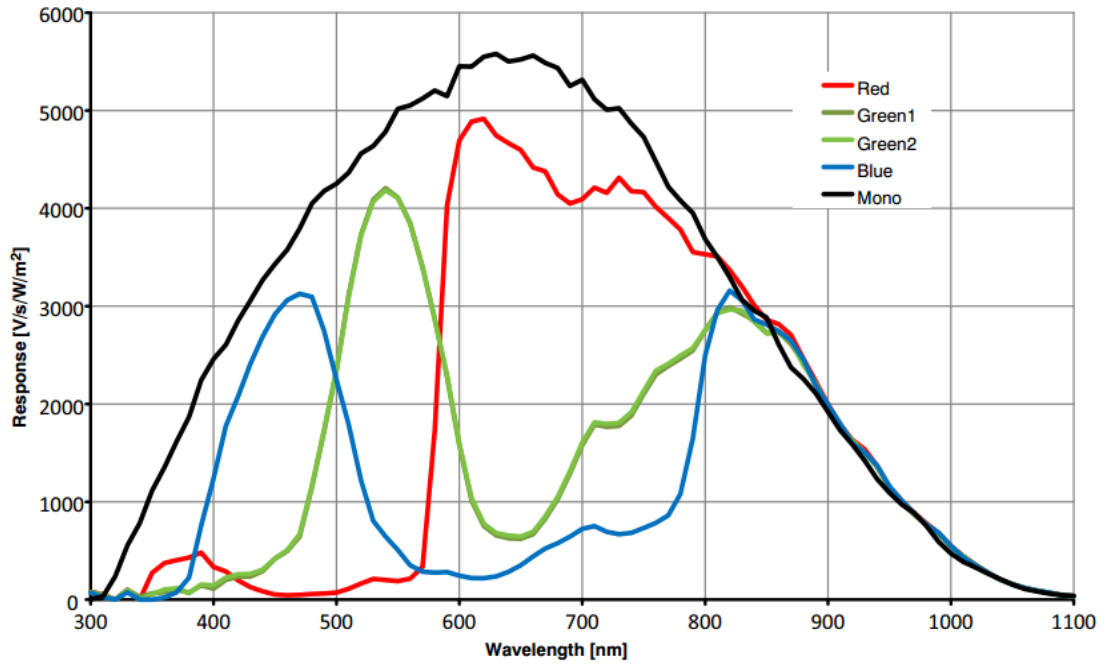

Figure 4-1 MER-031-860U3M/C(-L)/MER-050-560U3M/C(-L)/MER-131-210U3M/C(-L) sensor spectral response

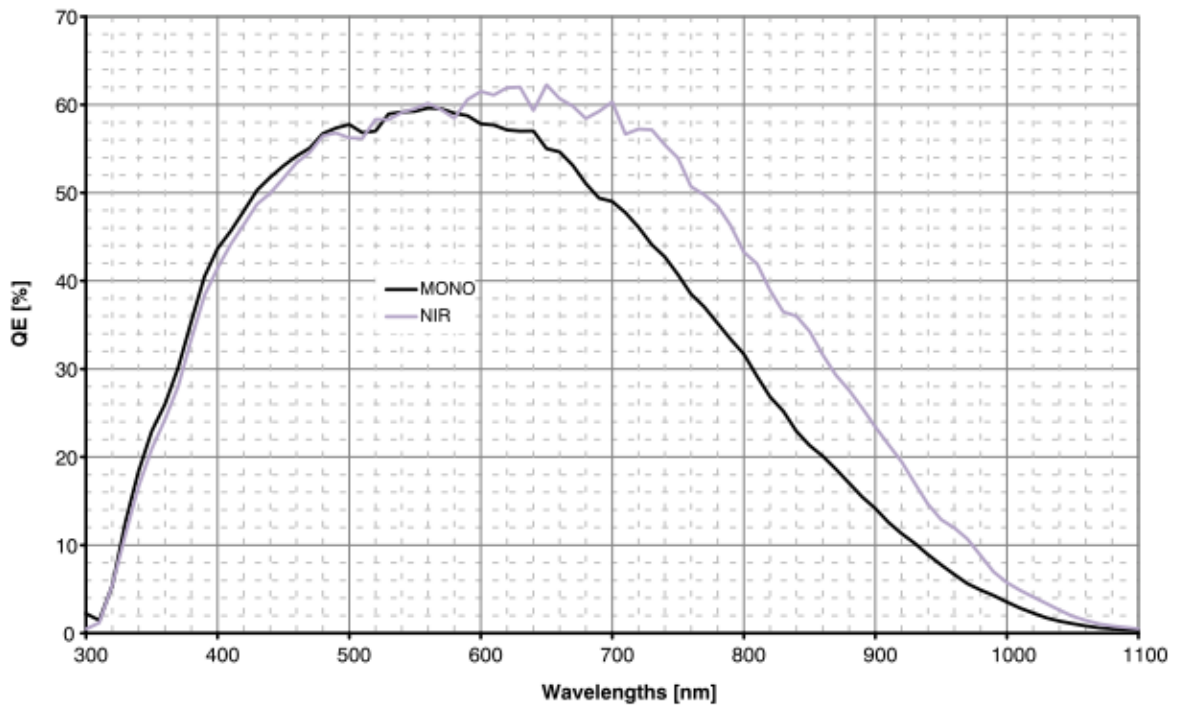

Figure 4-2 MER-031-860U3M(-L) NIR/MER-050-560U3M(-L) NIR/MER-131-210U3M(-L) NIR sensor spectral response

### 4.3. MER-031-860U3M(-L) NIR

#### 4.3.1. Parameter

Specifications	MER-031-860U3M NIR	MER-031-860U3M-L NIR
Resolution	640 × 480	
Sensor Type	Onsemi PYTHON 300 global shutter CMOS	
Optical Size	1/4 inch	
Pixel Size	4.8μm×4.8μm	
Frame Rate	860fps @ 640 × 480	
ADC Bit Depth	10bit	
Pixel Bit Depth	8bit, 10bit	
Shutter Time	20μs~1s	
Gain	0dB~16dB	
Pixel Data Formats	Mono8/Mono10	
Signal Noise Ratio	37.45dB	
Synchronization	External trigger, software trigger	Software trigger
I/O	1 input and 1 output with opto-isolated, 2 programmable GPIOs	N/A
Operating Temp.	0°C~45°C	
Storage Temp.	-20°C~70°C	
Operating Humidity	10%~80%	
Power Consumption	< 2.7W@5V	
Lens Mount	C	
Dimensions	29mm×29 mm×29mm (without lens adapter or connectors)	
Weight	57g	53g

Software	Windows XP/Win7/Win8/Win10 32bit, 64bit OS	
Data Interface	USB3.0	
Programmable Control	Image size, gain, exposure time, trigger polarity, flash polarity	Image size, gain, exposure time
Conformity	CE, RoHS, FCC, USB3 Vision, GenICam	

Table 4-3 MER-031-860U3M(-L) NIR camera specifications

### 4.3.2. Spectral Response

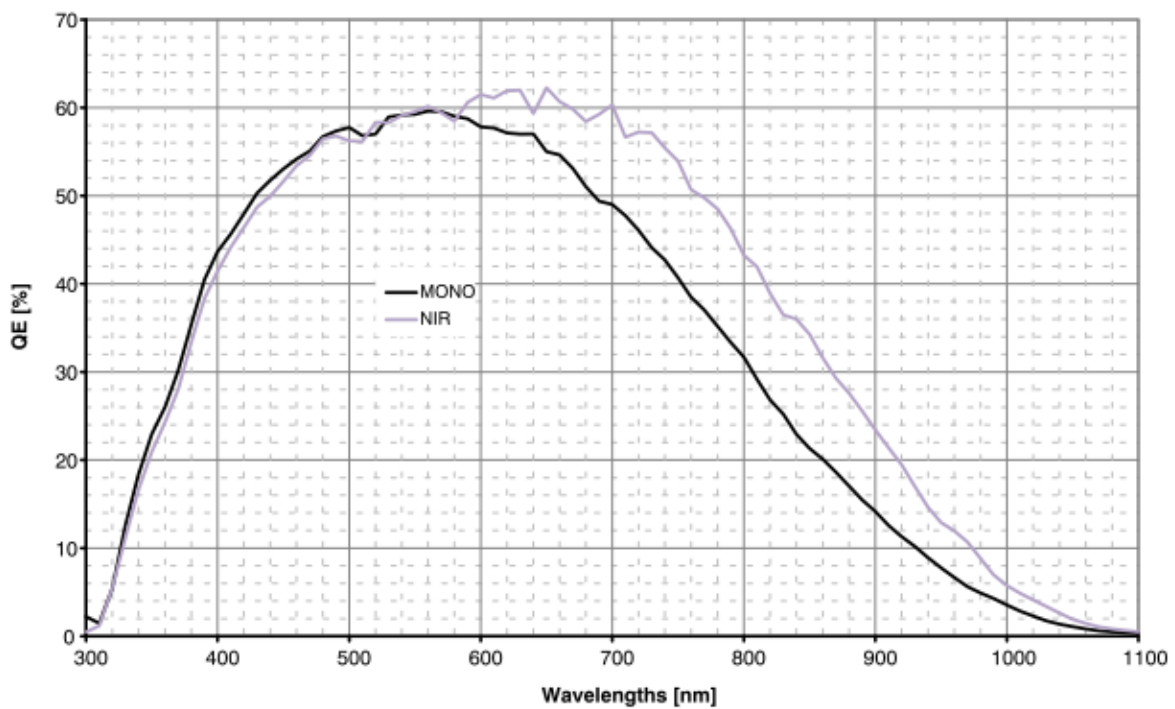

Figure 4-3 MER-031-860U3M(-L) NIR/MER-050-560U3M(-L) NIR/MER-131-210U3M(-L) NIR sensor spectral response

## 4.4. MER-041-436U3M/C(-L)

### 4.4.1. Parameter

Specifications	MER-041-436U3C	MER-041-436U3C-L
Resolution	720×540	
Sensor Type	Sony IMX287 global shutter CMOS	
Optical Size	1/2.9 inch	
Pixel Size	6.9μm×6.9μm	

Frame Rate	438fps @ 720x540	
ADC Bit Depth	10bit	
Pixel Bit Depth	8bit, 10bit	
Shutter Time	20μs~1s	
Gain	0dB~24dB	
Pixel Data Formats	Bayer RG8/Bayer RG10	
Signal Noise Ratio	44dB	
Synchronization	External trigger, software trigger	Software trigger
I/O	1 input and 1 output with opto-isolated, 2 programmable GPIOs	N/A
Operating Temp.	0°C~45°C	
Storage Temp.	-20°C~70°C	
Operating Humidity	10%~80%	
Power Consumption	< 2.7W@5V	
Lens Mount	C	
Dimensions	29mm×29 mm×29mm (without lens adapter or connectors)	
Weight	57g	53g
Software	Windows XP/Win7/Win8/Win10 32bit, 64bit OS	
Data Interface	USB3.0	
Programmable Control	Image size, gain, exposure time, trigger polarity, flash polarity	Image size, gain, exposure time
Conformity	CE, RoHS, FCC, USB3 Vision, GenICam	

Table 4-4 MER-041-436U3C(-L) camera specifications

Specifications	MER-041-436U3M	MER-041-436U3M-L
Resolution	720x540	
Sensor Type	Sony IMX287 global shutter CMOS	

Optical Size	1/2.9 inch	
Pixel Size	6.9μm×6.9μm	
Frame Rate	438fps @ 720×540	
ADC Bit Depth	10bit	
Pixel Bit Depth	8bit, 10bit	
Shutter Time	20μs~1s	
Gain	0dB~24dB	
Pixel Data Formats	Mono8/Mono10	
Signal Noise Ratio	43.46dB	
Synchronization	External trigger, software trigger	Software trigger
I/O	1 input and 1 output with opto-isolated, 2 programmable GPIOs	N/A
Operating Temp.	0°C~45°C	
Storage Temp.	-20°C~70°C	
Operating Humidity	10%~80%	
Power Consumption	< 2.7W@5V	
Lens Mount	C	
Dimensions	29mm×29 mm×29mm (without lens adapter or connectors)	
Weight	57g	53g
Software	Windows XP/Win7/Win8/Win10 32bit, 64bit OS	
Data Interface	USB3.0	
Programmable Control	Image size, gain, exposure time, trigger polarity, flash polarity	Image size, gain, exposure time
Conformity	CE, RoHS, FCC, USB3 Vision, GenICam	

Table 4-5 MER-041-436U3M(-L) camera specifications

### 4.4.2. Spectral Response

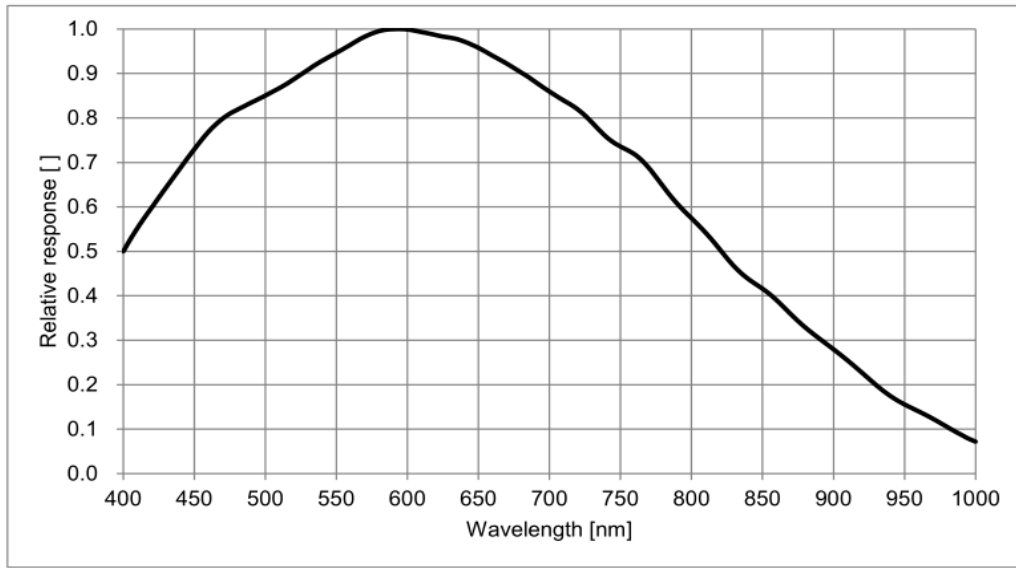

Figure 4-4 MER-041-436U3M(-L) sensor spectral response

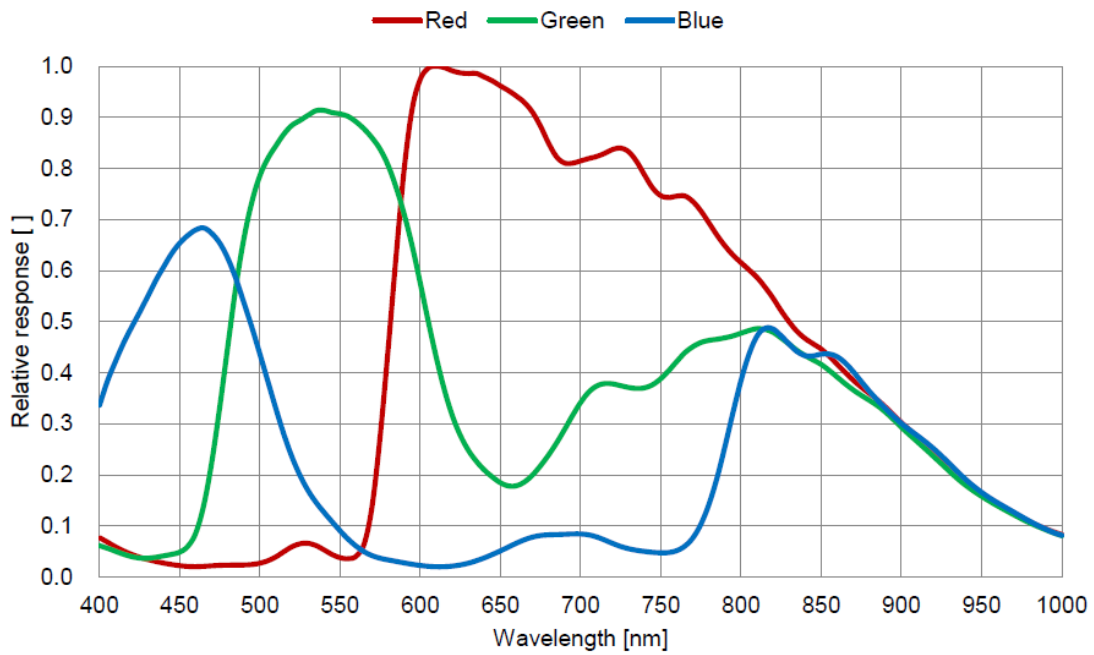

Figure 4-5 MER-041-436U3C(-L) sensor spectral response

## 4.5. MER-050-560U3M/C(-L)

### 4.5.1. Parameter

Specifications	MER-050-560U3C	MER-050-560U3C-L
Resolution	800 × 600	

Sensor Type	Onsemi PYTHON 500 global shutter CMOS	
Optical Size	1/3.6 inch	
Pixel Size	4.8 $\mu$ m $\times$ 4.8 $\mu$ m	
Frame Rate	560fps @ 800 $\times$ 600	
ADC Bit Depth	10bit	
Pixel Bit Depth	8bit, 10bit	
Shutter Time	20 $\mu$ s~1s	
Gain	0dB~16dB	
Pixel Data Formats	Bayer RG8/Bayer RG10	
Signal Noise Ratio	37.84dB	
Synchronization	External trigger, software trigger	Software trigger
I/O	1 input and 1 output with opto-isolated, 2 programmable GPIOs	N/A
Operating Temp.	0 $^{\circ}$ C~45 $^{\circ}$ C	
Storage Temp.	-20 $^{\circ}$ C~70 $^{\circ}$ C	
Operating Humidity	10%~80%	
Power Consumption	< 2.7W@5V	
Lens Mount	C	
Dimensions	29mm $\times$ 29 mm $\times$ 29mm (without lens adapter or connectors)	
Weight	57g	53g
Software	Windows XP/Win7/Win8/Win10 32bit, 64bit OS	
Data Interface	USB3.0	
Programmable Control	Image size, gain, exposure time, trigger polarity, flash polarity	Image size, gain, exposure time



Conformity	CE, RoHS, FCC, USB3 Vision, GenICam
------------	-------------------------------------

Table 4-6 MER-050-560U3C(-L) camera specifications

Specifications	MER-050-560U3M	MER-050-560U3M-L
Resolution	800 × 600	
Sensor Type	Onsemi PYTHON 500 global shutter CMOS	
Optical Size	1/3.6 inch	
Pixel Size	4.8μm × 4.8μm	
Frame Rate	560fps @ 800 × 600	
ADC Bit Depth	10bit	
Pixel Bit Depth	8bit, 10bit	
Shutter Time	20μs~1s	
Gain	0dB~16dB	
Pixel Data Formats	Mono8/Mono10	
Signal Noise Ratio	37.82dB	
Synchronization	External trigger, software trigger	Software trigger
I/O	1 input and 1 output with opto-isolated, 2 programmable GPIOs	N/A
External Trigger and Light Source Control Line	Shielded industrial interface	N/A
Operating Temp.	0°C~45°C	
Storage Temp.	-20°C~70°C	
Operating Humidity	10%~80%	
Power Consumption	< 2.7W@5V	
Lens Mount	C	

Dimensions	29mm×29 mm×29mm (without lens adapter or connectors)	
Weight	57g	53g
Software	Windows XP/Win7/Win8/Win10 32bit, 64bit OS	
Data Interface	USB3.0	
Programmable Control	Image size, gain, exposure time, trigger polarity, flash polarity	Image size, gain, exposure time
Conformity	CE, RoHS, FCC, USB3 Vision, GenICam	

Table 4-7 MER-050-560U3M(-L) camera specifications

#### 4.5.2. Spectral Response

For the spectral response of MER-050-560U3M/C(-L), please see [section 4.2.2](#).

### 4.6. MER-050-560U3M(-L) NIR

#### 4.6.1. Parameter

Specifications	MER-050-560U3M NIR	MER-050-560U3M-L NIR
Resolution	800 × 600	
Sensor Type	Onsemi PYTHON 500 global shutter CMOS	
Optical Size	1/3.6 inch	
Pixel Size	4.8μm × 4.8μm	
Frame Rate	560fps @ 800 × 600	
ADC Bit Depth	10bit	
Pixel Bit Depth	8bit, 10bit	
Shutter Time	20μs~1s	
Gain	0dB~16dB	
Pixel Data Formats	Mono8/Mono10	
Signal Noise Ratio	37.8dB	

Synchronization	External trigger, software trigger	Software trigger
I/O	1 input and 1 output with opto-isolated, 2 programmable GPIOs	N/A
Operating Temp.	0°C~45°C	
Storage Temp.	-20°C~70°C	
Operating Humidity	10%~80%	
Power Consumption	< 2.7W@5V	
Lens Mount	C	
Dimensions	29mm×29 mm×29mm (without lens adapter or connectors)	
Weight	57g	53g
Software	Windows XP/Win7/Win8/Win10 32bit, 64bit OS	
Data Interface	USB3.0	
Programmable Control	Image size, gain, exposure time, trigger polarity, flash polarity	Image size, gain, exposure time
Conformity	CE, RoHS, FCC, USB3 Vision, GenICam	

Table 4-8 MER-050-560U3M(-L) NIR camera specifications

#### 4.6.2. Spectral Response

For the spectral response of MER-050-560U3M(-L) NIR, please see [section 4.3.2](#).

### 4.7. MER-051-120U3M/C(-L)

#### 4.7.1. Parameter

Specifications	MER-051-120U3C	MER-051-120U3C-L
Resolution	808 × 608	
Sensor Type	Onsemi PYTHON 480 global shutter CMOS	
Optical Size	1/3.6 inch	
Pixel Size	4.8μm × 4.8μm	

Frame Rate	120fps @ 808 × 608	
ADC Bit Depth	10bit	
Pixel Bit Depth	8bit, 10bit	
Shutter Time	5μs~1s	
Gain	0dB~16dB	
Pixel Data Formats	Bayer RG8/Bayer RG10	
Signal Noise Ratio	40dB	
Synchronization	External trigger, software trigger	Software trigger
I/O	1 input and 1 output with opto-isolated, 2 programmable GPIOs	N/A
Operating Temp.	0°C~45°C	
Storage Temp.	-20°C~70°C	
Operating Humidity	10%~80%	
Power Consumption	< 2.7W@5V	
Lens Mount	C	
Dimensions	29mm×29 mm×29mm (without lens adapter or connectors)	
Weight	57g	53g
Software	Windows XP/Win7/Win8/Win10 32bit, 64bit OS	
Data Interface	USB3.0	
Programmable Control	Image size, gain, exposure time, trigger polarity, flash polarity	Image size, gain, exposure time
Conformity	CE, RoHS, FCC, USB3 Vision, GenICam	

Table 4-9 MER-051-120U3C(-L) camera specifications

Specifications	MER-051-120U3M	MER-051-120U3M-L
Resolution	808 × 608	
Sensor Type	Onsemi PYTHON 480 global shutter CMOS	

Optical Size	1/3.6 inch	
Pixel Size	4.8 $\mu$ m $\times$ 4.8 $\mu$ m	
Frame Rate	120fps @ 808 $\times$ 608	
ADC Bit Depth	10bit	
Pixel Bit Depth	8bit, 10bit	
Shutter Time	5 $\mu$ s~1s	
Gain	0dB~16dB	
Pixel Data Formats	Mono8/Mono10	
Signal Noise Ratio	38.01dB	
Synchronization	External trigger, software trigger	Software trigger
I/O	1 input and 1 output with opto-isolated, 2 programmable GPIOs	N/A
Operating Temp.	0°C~45°C	
Storage Temp.	-20°C~70°C	
Operating Humidity	10%~80%	
Power Consumption	< 2.7W@5V	
Lens Mount	C	
Dimensions	29mm $\times$ 29 mm $\times$ 29mm (without lens adapter or connectors)	
Weight	57g	53g
Software	Windows XP/Win7/Win8/Win10 32bit, 64bit OS	
Data Interface	USB3.0	
Programmable Control	Image size, gain, exposure time, trigger polarity, flash polarity	Image size, gain, exposure time
Conformity	CE, RoHS, FCC, USB3 Vision, GenICam	

Table 4-10 MER-051-120U3M(-L) camera specifications

### 4.7.2. Spectral Response

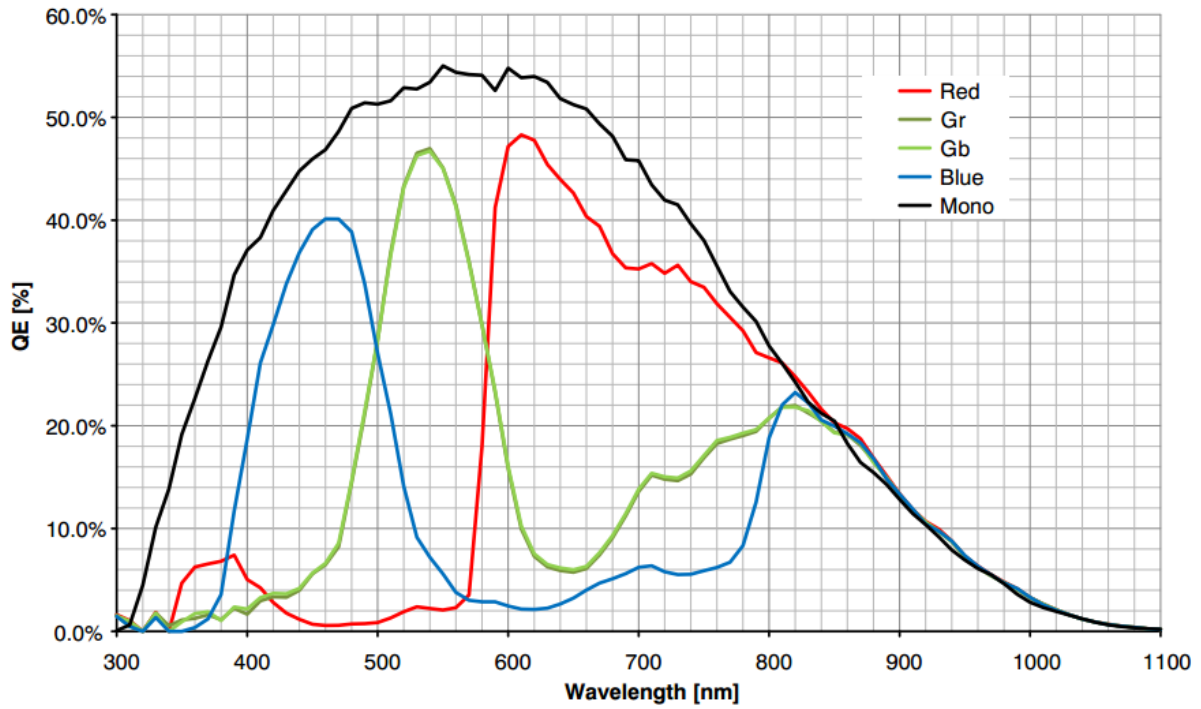

Figure 4-6 MER-051-120U3M/C(-L) sensor spectral response

## 4.8. MER-131-210U3M/C(-L)

### 4.8.1. Parameter

Specifications	MER-131-210U3C	MER-131-210U3C-L
Resolution	1280 × 1024	
Sensor Type	Onsemi PYTHON 1300 global shutter CMOS	
Optical Size	1/2 inch	
Pixel Size	4.8μm × 4.8μm	
Frame Rate	210fps @ 1280 × 1024	
ADC Bit Depth	10bit	
Pixel Bit Depth	8bit, 10bit	
Shutter Time	20μs~1s	
Gain	0dB~16dB	

Pixel Data Formats	Bayer RG8/Bayer RG10	
Signal Noise Ratio	37.45dB	
Synchronization	External trigger, software trigger	Software trigger
I/O	1 input and 1 output with opto-isolated, 2 programmable GPIOs	N/A
Operating Temp.	0°C~45°C	
Storage Temp.	-20°C~70°C	
Operating Humidity	10%~80%	
Power Consumption	< 2.7W@5V	
Lens Mount	C	
Dimensions	29mm×29 mm×29mm (without lens adapter or connectors)	
Weight	57g	53g
Software	Windows XP/Win7/Win8/Win10 32bit, 64bit OS	
Data Interface	USB3.0	
Programmable Control	Image size, gain, exposure time, trigger polarity, flash polarity	Image size, gain, exposure time
Conformity	CE, RoHS, FCC, USB3 Vision, GenICam	

Table 4-11 MER-131-210U3C(-L) camera specifications

Specifications	MER-131-210U3M	MER-131-210U3M-L
Resolution	1280 × 1024	
Sensor Type	Onsemi PYTHON 1300 global shutter CMOS	
Optical Size	1/2 inch	
Pixel Size	4.8μm × 4.8μm	
Frame Rate	210fps @ 1280 × 1024	

ADC Bit Depth	10bit	
Pixel Bit Depth	8bit, 10bit	
Shutter Time	20 $\mu$ s~1s	
Gain	0dB~16dB	
Pixel Data Formats	Mono8/Mono10	
Signal Noise Ratio	37.3dB	
Synchronization	External trigger, software trigger	Software trigger
I/O	1 input and 1 output with opto-isolated, 2 programmable GPIOs	N/A
Operating Temp.	0°C~45°C	
Storage Temp.	-20°C~70°C	
Operating Humidity	10%~80%	
Power Consumption	< 2.7W@5V	
Lens Mount	C	
Dimensions	29mm×29 mm×29mm (without lens adapter or connectors)	
Weight	57g	53g
Software	Windows XP/Win7/Win8/Win10 32bit, 64bit OS	
Data Interface	USB3.0	
Programmable Control	Image size, gain, exposure time, trigger polarity, flash polarity	Image size, gain, exposure time
Conformity	CE, RoHS, FCC, USB3 Vision, GenICam	

Table 4-12 MER-131-210U3M(-L) camera specifications

#### 4.8.2. Spectral Response

For the spectral response of MER-131-210U3M/C(-L), please see [section 4.2.2](#).



## 4.9. MER-131-210U3M(-L) NIR

### 4.9.1. Parameter

Specifications	MER-131-210U3M NIR	MER-131-210U3M-L NIR
Resolution	1280 × 1024	
Sensor Type	Onsemi PYTHON 1300 global shutter CMOS	
Optical Size	1/2 inch	
Pixel Size	4.8μm × 4.8μm	
Frame Rate	210fps @ 1280 × 1024	
ADC Bit Depth	10bit	
Pixel Bit Depth	8bit, 10bit	
Shutter Time	20μs~1s	
Gain	0dB~16dB	
Pixel Data Formats	Mono8/Mono10	
Signal Noise Ratio	37.84dB	
Synchronization	External trigger, software trigger	Software trigger
I/O	1 input and 1 output with opto-isolated, 2 programmable GPIOs	N/A
Operating Temp.	0°C~45°C	
Storage Temp.	-20°C~70°C	
Operating Humidity	10%~80%	
Power Consumption	< 2.7W@5V	
Lens Mount	C	
Dimensions	29mm×29 mm×29mm (without lens adapter or connectors)	
Weight	57g	53g

Software	Windows XP/Win7/Win8/Win10 32bit, 64bit OS	
Data Interface	USB3.0	
Programmable Control	Image size, gain, exposure time, trigger polarity, flash polarity	Image size, gain, exposure time
Conformity	CE, RoHS, FCC, USB3 Vision, GenICam	

Table 4-13 MER-131-210U3M(-L) NIR camera specifications

#### 4.9.2. Spectral Response

For the spectral response of MER-131-210U3M(-L) NIR, please see [section 4.3.2](#).

### 4.10. MER-132-43U3M/C(-L)

#### 4.10.1. Parameter

Specifications	MER-132-43U3C	MER-132-43U3C-L
Resolution	1292 × 964	
Sensor Type	sharp RJ33J global shutter CCD	
Optical Size	1/3 inch	
Pixel Size	3.75μm × 3.75μm	
Frame Rate	43fps @ 1292 × 964	
ADC Bit Depth	12bit	
Pixel Bit Depth	8bit, 12bit	
Shutter Time	20μs~1s	
Gain	0dB~25dB	
Pixel Data Formats	Bayer RG8/Bayer RG12	
Signal Noise Ratio	49dB	
Synchronization	External trigger, software trigger	Software trigger
I/O	1 input and 1 output with opto-isolated, 2 programmable GPIOs	N/A

Operating Temp.	0°C~45°C	
Storage Temp.	-20°C~70°C	
Operating Humidity	10%~80%	
Power Consumption	< 2.7W@5V	
Lens Mount	C	
Dimensions	29mm×29 mm×29mm (without lens adapter or connectors)	
Weight	57g	53g
Software	Windows XP/Win7/Win8/Win10 32bit, 64bit OS	
Data Interface	USB3.0	
Programmable Control	Image size, gain, exposure time, trigger polarity, flash polarity	Image size, gain, exposure time
Conformity	CE, RoHS, FCC, USB3 Vision, GenICam	

Table 4-14 MER-132-43U3C(-L) camera specifications

Specifications	MER-132-43U3M	MER-132-43U3M-L
Resolution	1292 × 964	
Sensor Type	sharp RJ33J global shutter CCD	
Optical Size	1/3 inch	
Pixel Size	3.75μm × 3.75μm	
Frame Rate	43fps @ 1292 × 964	
ADC Bit Depth	12bit	
Pixel Bit Depth	8bit, 12bit	
Shutter Time	20μs~1s	
Gain	0dB~25dB	

Pixel Data Formats	Mono8/Mono12	
Signal Noise Ratio	39.63dB	
Synchronization	External trigger, software trigger	Software trigger
I/O	1 input and 1 output with opto-isolated, 2 programmable GPIOs	N/A
Operating Temp.	0°C~45°C	
Storage Temp.	-20°C~70°C	
Operating Humidity	10%~80%	
Power Consumption	< 2.7W@5V	
Lens Mount	C	
Dimensions	29mm×29 mm×29mm (without lens adapter or connectors)	
Weight	57g	53g
Software	Windows XP/Win7/Win8/Win10 32bit, 64bit OS	
Data Interface	USB3.0	
Programmable Control	Image size, gain, exposure time, trigger polarity, flash polarity	Image size, gain, exposure time
Conformity	CE, RoHS, FCC, USB3 Vision, GenICam	

Table 4-15 MER-132-43U3M(-L) camera specifications

4.10.2. Spectral Response

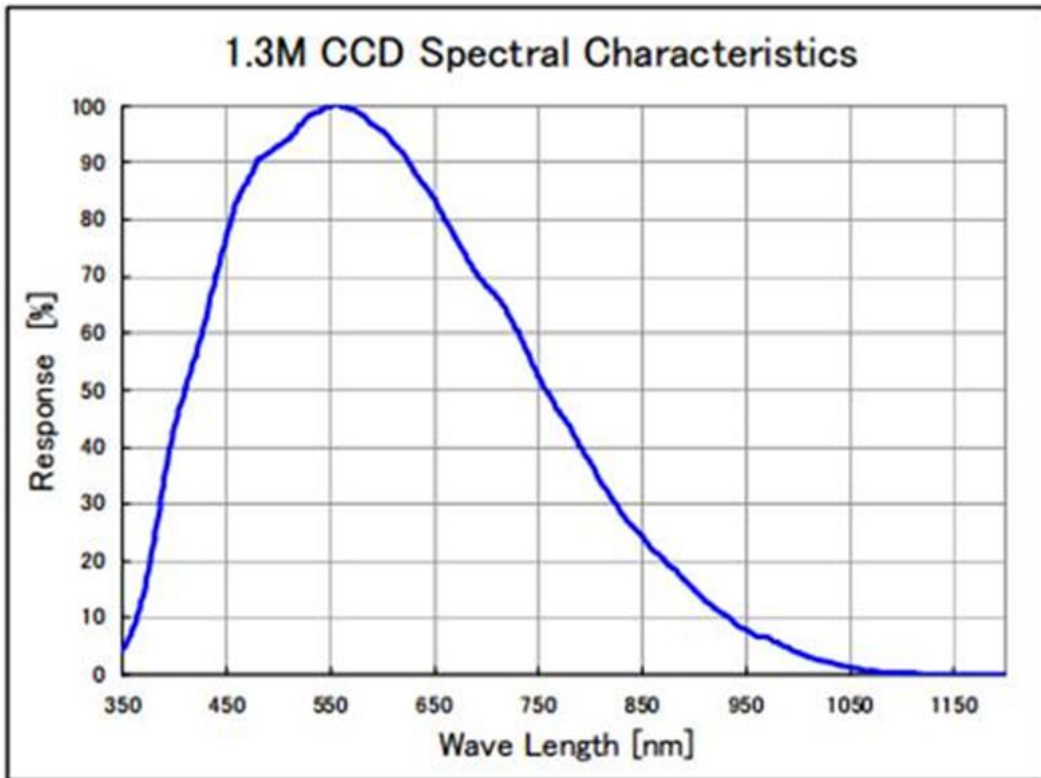

Figure 4-7 MER-132-43U3M(-L) sensor spectral response

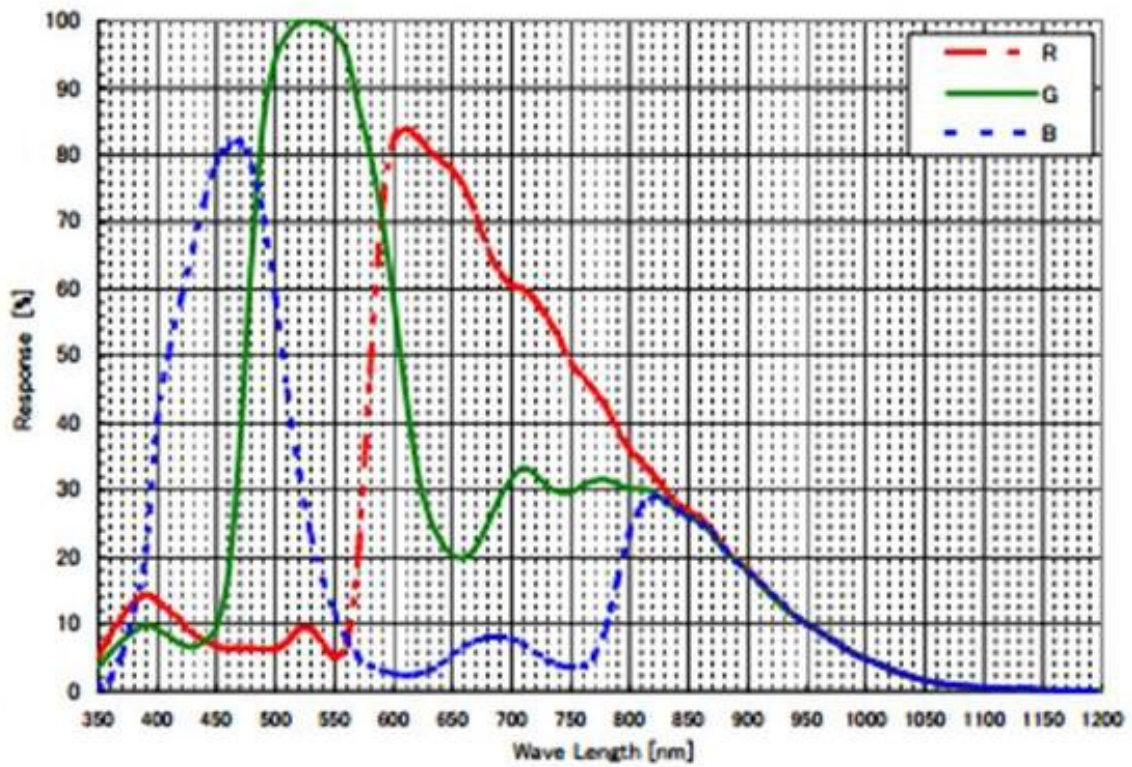

Figure 4-8 MER-132-43U3C(-L) sensor spectral response

## 4.11. MER-131-210U3M/C(-L)

### 4.11.1. Parameter

Specifications	MER-133-54U3C	MER-133-54U3C-L
Resolution	1280× 960	
Sensor Type	Onsemi AR0135 global shutter CMOS	
Optical Size	1/3 inch	
Pixel Size	3.75μm × 3.75μm	
Frame Rate	54fps@1280× 960	
ADC Bit Depth	12bit	
Pixel Bit Depth	8bit, 10bit	
Shutter Time	20μs~1s	
Gain	0dB~31dB	
Pixel Data Formats	Bayer GR8/Bayer GR10	
Signal Noise Ratio	40dB	
Synchronization	External trigger, software trigger	Software trigger
I/O	1 input and 1 output with opto-isolated, 2 programmable GPIOs	N/A
Operating Temp.	0°C~45°C	
Storage Temp.	-20°C~70°C	
Operating Humidity	10%~80%	
Power Consumption	< 2.7W@5V	
Lens Mount	C	
Dimensions	29mm×29 mm×29mm (without lens adapter or connectors)	
Weight	57g	53g

Software	Windows XP/Win7/Win8/Win10 32bit, 64bit OS	
Data Interface	USB3.0	
Programmable Control	Image size, gain, exposure time, trigger polarity, flash polarity	Image size, gain, exposure time
Conformity	CE, RoHS, FCC, USB3 Vision, GenICam	

Table 4-16 MER-133-54U3C(-L) camera specifications

Specifications	MER-133-54U3M	MER-133-54U3M-L
Resolution	1280×960	
Sensor Type	Onsemi AR0135 global shutter CMOS	
Optical Size	1/3 inch	
Pixel Size	3.75μm × 3.75μm	
Frame Rate	54fps@1280× 960	
ADC Bit Depth	12bit	
Pixel Bit Depth	8bit, 10bit	
Shutter Time	20μs~1s	
Gain	0dB~31dB	
Pixel Data Formats	Mono8/Mono10	
Signal Noise Ratio	38.79dB	
Synchronization	External trigger, software trigger	Software trigger
I/O	1 input and 1 output with opto-isolated, 2 programmable GPIOs	N/A
Operating Temp.	0°C~45°C	
Storage Temp.	-20°C~70°C	
Operating Humidity	10%~80%	

Power Consumption	< 2.7W@5V	
Lens Mount	C	
Dimensions	29mm×29 mm×29mm (without lens adapter or connectors)	
Weight	57g	53g
Software	Windows XP/Win7/Win8/Win10 32bit, 64bit OS	
Data Interface	USB3.0	
Programmable Control	Image size, gain, exposure time, trigger polarity, flash polarity	Image size, gain, exposure time
Conformity	CE, RoHS, FCC, USB3 Vision, GenICam	

Table 4-17 MER-133-54U3M(-L) camera specifications

#### 4.11.2. Spectral Response

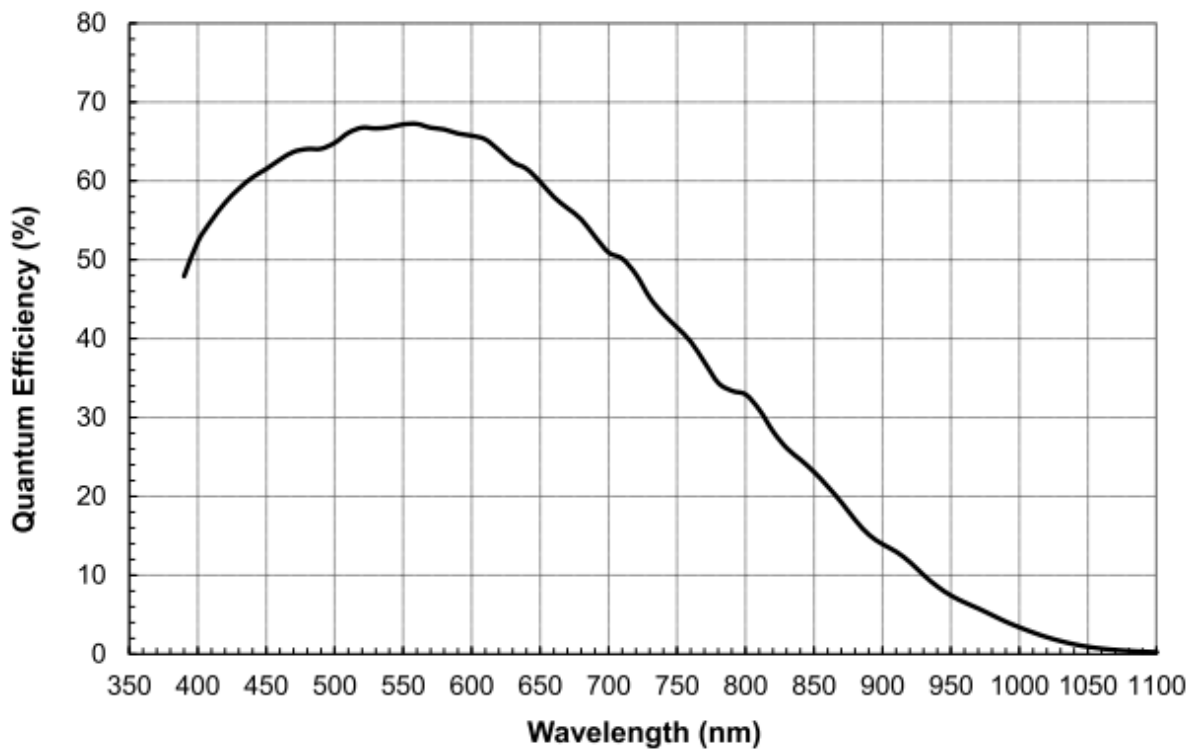

Figure 4-9 MER-133-54U3M(-L) sensor spectral response



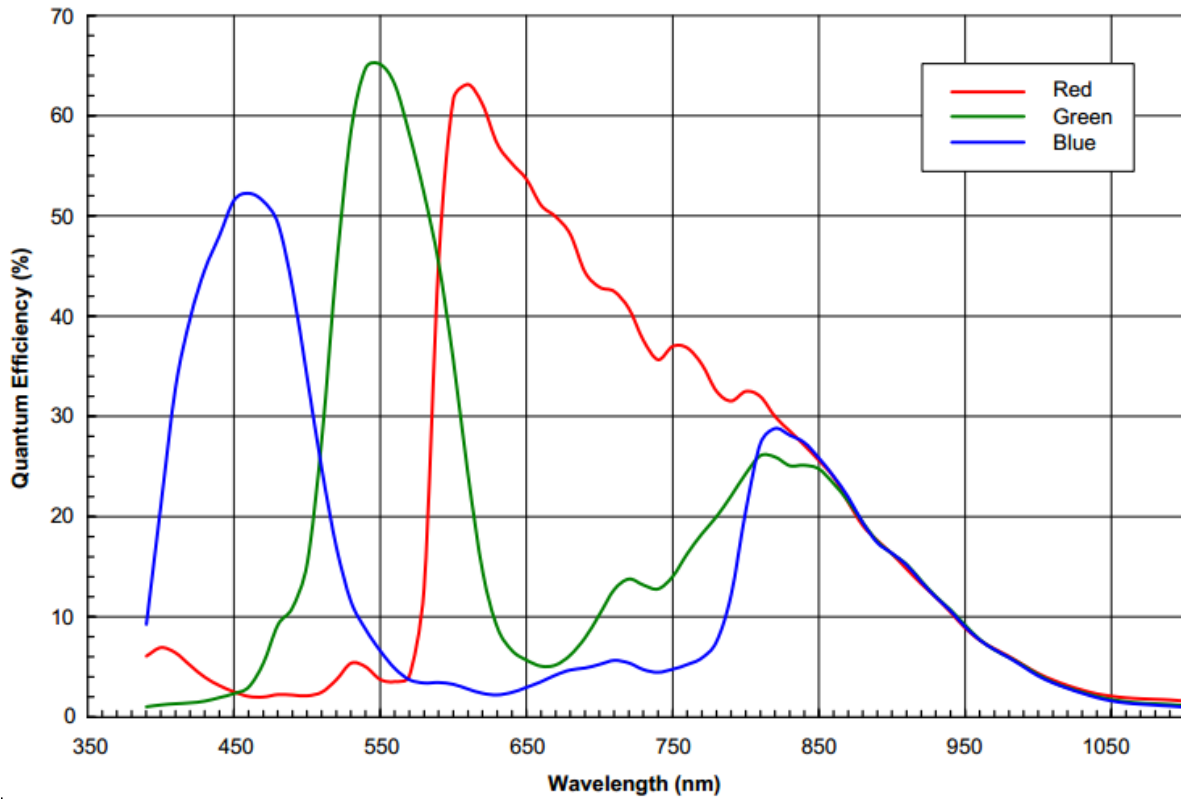

Figure 4-10 MER-133-54U3C(-L) sensor spectral response

## 4.12. MER-134-93U3M/C(-L)

### 4.12.1. Parameter

Specifications	MER-134-93U3C	MER-134-93U3C-L
Resolution	1280 × 1024	
Sensor Type	Onsemi PYTHON 1300 global shutter CMOS	
Optical Size	1/2 inch	
Pixel Size	4.8μm × 4.8μm	
Frame Rate	93fps @ 1280 × 1024	
ADC Bit Depth	10bit	
Pixel Bit Depth	8bit, 10bit	
Shutter Time	5μs~1s	
Gain	0dB~16dB	

Pixel Data Formats	Bayer RG8/Bayer RG10	
Signal Noise Ratio	38.69dB	
Synchronization	External trigger, software trigger	Software trigger
I/O	1 input and 1 output with opto-isolated, 2 programmable GPIOs	N/A
Operating Temp.	0°C~45°C	
Storage Temp.	-20°C~70°C	
Operating Humidity	10%~80%	
Power Consumption	< 2.7W@5V	
Lens Mount	C	
Dimensions	29mm×29 mm×29mm (without lens adapter or connectors)	
Weight	57g	53g
Software	Windows XP/Win7/Win8/Win10 32bit, 64bit OS	
Data Interface	USB3.0	
Programmable Control	Image size, gain, exposure time, trigger polarity, flash polarity	Image size, gain, exposure time
Conformity	CE, RoHS, FCC, USB3 Vision, GenICam	

Table 4-18 MER-134-93U3C(-L) camera specifications

Specifications	MER-134-93U3M	MER-134-93U3M-L
Resolution	1280 × 1024	
Sensor Type	Onsemi PYTHON 1300 global shutter CMOS	
Optical Size	1/2 inch	
Pixel Size	4.8μm × 4.8μm	
Frame Rate	93fps @ 1280 × 1024	

ADC Bit Depth	10bit	
Pixel Bit Depth	8bit, 10bit	
Shutter Time	5 $\mu$ s~1s	
Gain	0dB~16dB	
Pixel Data Formats	Mono8/Mono10	
Signal Noise Ratio	38.12dB	
Synchronization	External trigger, software trigger	Software trigger
I/O	1 input and 1 output with opto-isolated, 2 programmable GPIOs	N/A
Operating Temp.	0°C~45°C	
Storage Temp.	-20°C~70°C	
Operating Humidity	10%~80%	
Power Consumption	< 2.7W@5V	
Lens Mount	C	
Dimensions	29mmx29 mmx29mm (without lens adapter or connectors)	
Weight	57g	53g
Software	Windows XP/Win7/Win8/Win10 32bit, 64bit OS	
Data Interface	USB3.0	
Programmable Control	Image size, gain, exposure time, trigger polarity, flash polarity	Image size, gain, exposure time
Conformity	CE, RoHS, FCC, USB3 Vision, GenICam	

Table 4-19 MER-134-93U3M(-L) camera specifications

### 4.12.2. Spectral Response

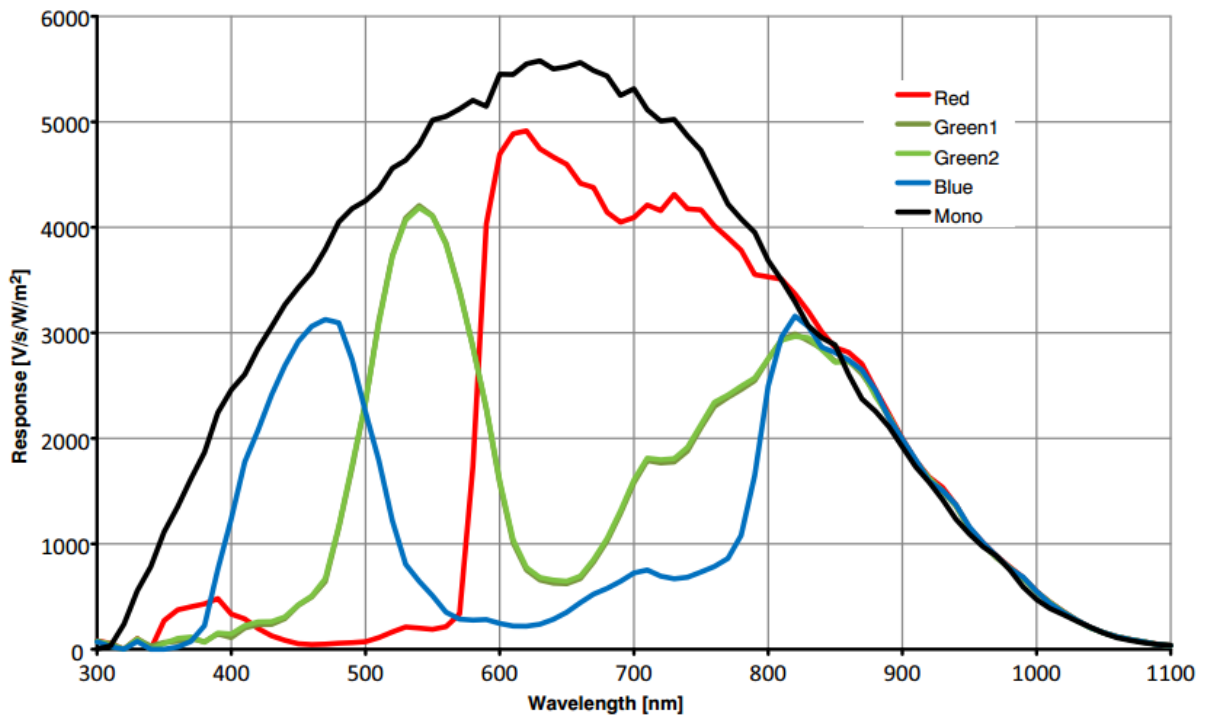

Figure 4-11 MER-134-93U3M/C(-L) sensor spectral response

### 4.13. MER-160-227U3M/C(-L)

#### 4.13.1. Parameter

Specifications	MER-160-227U3C	MER-160-227U3C-L
Resolution	1440 × 1080	
Sensor Type	Sony IMX273 global shutter CMOS	
Optical Size	1/2.9 inch	
Pixel Size	3.45μm × 3.45μm	
Frame Rate	227fps@1440 × 1080	
ADC Bit Depth	10bit	
Pixel Bit Depth	8bit, 10bit	
Shutter Time	20μs~1s	
Gain	0dB~24dB	

Pixel Data Formats	Bayer RG8/Bayer RG10	
Signal Noise Ratio	41dB	
Synchronization	External trigger, software trigger	Software trigger
I/O	1 input and 1 output with opto-isolated, 2 programmable GPIOs	N/A
Operating Temp.	0°C~45°C	
Storage Temp.	-20°C~70°C	
Operating Humidity	10%~80%	
Power Consumption	< 2.7W@5V	
Lens Mount	C	
Dimensions	29mm×29 mm×29mm (without lens adapter or connectors)	
Weight	57g	53g
Software	Windows XP/Win7/Win8/Win10 32bit, 64bit OS	
Data Interface	USB3.0	
Programmable Control	Image size, gain, exposure time, trigger polarity, flash polarity	Image size, gain, exposure time
Conformity	CE, RoHS, FCC, USB3 Vision, GenICam	

Table 4-20 MER-160-227U3C(-L) camera specifications

Specifications	MER-160-227U3M	MER-160-227U3M-L
Resolution	1440 × 1080	
Sensor Type	Sony IMX273 global shutter CMOS	
Optical Size	1/2.9 inch	
Pixel Size	3.45μm × 3.45μm	
Frame Rate	227fps@1440× 1080	

ADC Bit Depth	10bit	
Pixel Bit Depth	8bit, 10bit	
Shutter Time	20 $\mu$ s~1s	
Gain	0dB~24dB	
Pixel Data Formats	Mono8/Mono10	
Signal Noise Ratio	41dB	
Synchronization	External trigger, software trigger	Software trigger
I/O	1 input and 1 output with opto-isolated, 2 programmable GPIOs	N/A
Operating Temp.	0°C~45°C	
Storage Temp.	-20°C~70°C	
Operating Humidity	10%~80%	
Power Consumption	< 2.7W@5V	
Lens Mount	C	
Dimensions	29mmx29 mmx29mm (without lens adapter or connectors)	
Weight	57g	53g
Software	Windows XP/Win7/Win8/Win10 32bit, 64bit OS	
Data Interface	USB3.0	
Programmable Control	Image size, gain, exposure time, trigger polarity, flash polarity	Image size, gain, exposure time
Conformity	CE, RoHS, FCC, USB3 Vision, GenICam	

Table 4-21 MER-160-227U3M(-L) camera specifications

### 4.13.2. Spectral Response

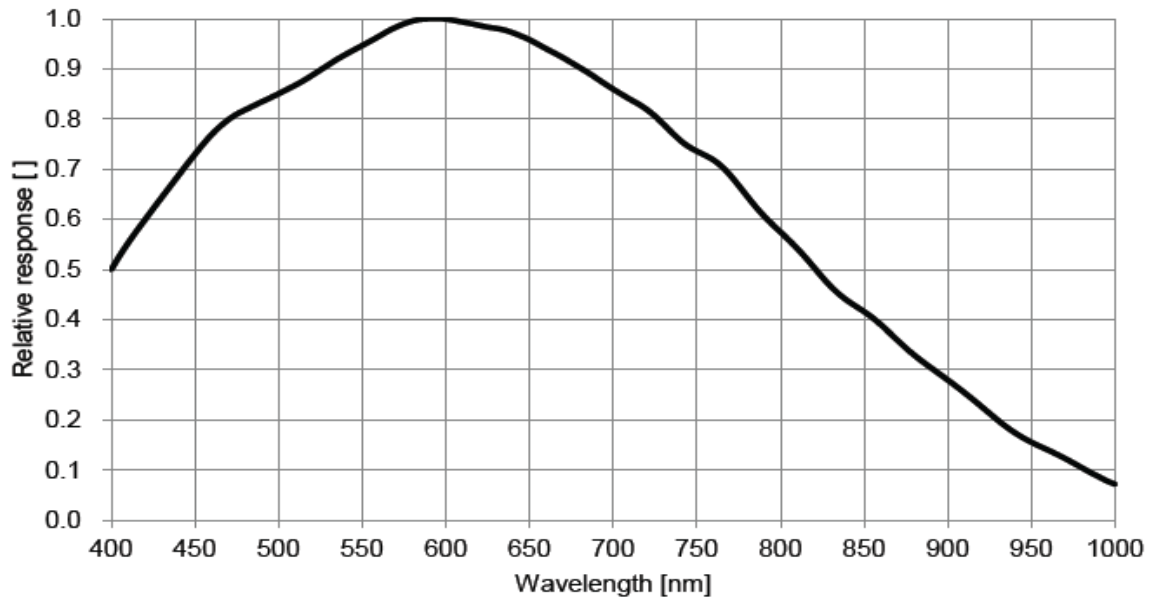

Figure 4-12 MER-160-227U3M(-L) sensor spectral response

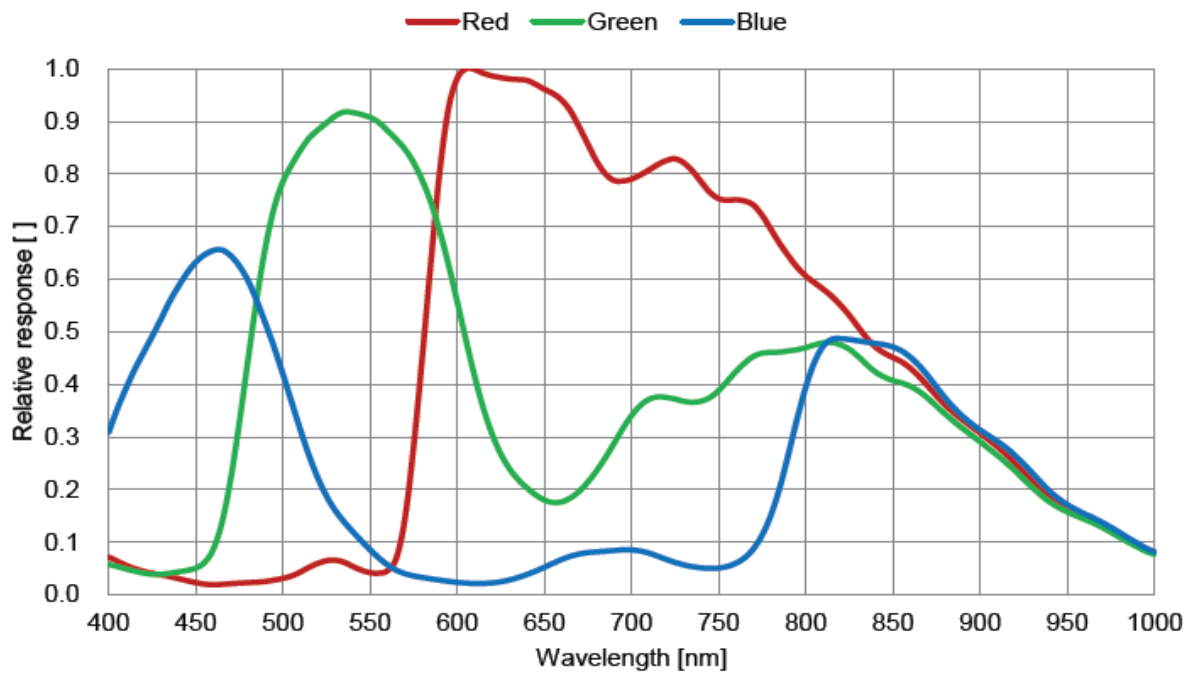

Figure 4-13 MER-160-227U3C(-L) sensor spectral response

## 4.14. MER-230-168U3M/C(-L)

### 4.14.1. Parameter

Specifications	MER-230-168U3C	MER-230-168U3C-L
----------------	----------------	------------------

Resolution	1920× 1200	
Sensor Type	Sony IMX174 global shutter CMOS	
Optical Size	1/1.2 inch	
Pixel Size	5.86μm ×5.86μm	
Frame Rate	168fps@1920× 1200	
ADC Bit Depth	10bit	
Pixel Bit Depth	8bit, 10bit	
Shutter Time	20μs~1s	
Gain	0dB~24dB	
Pixel Data Formats	Bayer RG8/Bayer RG10	
Signal Noise Ratio	45.32dB	
Synchronization	External trigger, software trigger	Software trigger
I/O	1 input and 1 output with opto-isolated, 2 programmable GPIOs	N/A
Operating Temp.	0°C~45°C	
Storage Temp.	-20°C~70°C	
Operating Humidity	10%~80%	
Power Consumption	< 2.7W@5V	
Lens Mount	C	
Dimensions	29mm×29 mm×29mm (without lens adapter or connectors)	
Weight	57g	53g
Software	Windows XP/Win7/Win8/Win10 32bit, 64bit OS	
Data Interface	USB3.0	



Programmable Control	Image size, gain, exposure time, trigger polarity, flash polarity	Image size, gain, exposure time
Conformity	CE, RoHS, FCC, USB3 Vision, GenICam	

Table 4-22 MER-230-168U3C(-L) camera specifications

Specifications	MER-230-168U3M	MER-230-168U3M-L
Resolution	1920× 1200	
Sensor Type	Sony IMX174 global shutter CMOS	
Optical Size	1/1.2 inch	
Pixel Size	5.86μm × 5.86μm	
Frame Rate	168fps@1920× 1200	
ADC Bit Depth	10bit	
Pixel Bit Depth	8bit, 10bit	
Shutter Time	20μs~1s	
Gain	0dB~24dB	
Pixel Data Formats	Mono8/Mono10	
Signal Noise Ratio	45.32dB	
Synchronization	External trigger, software trigger	Software trigger
I/O	1 input and 1 output with opto-isolated, 2 programmable GPIOs	N/A
Operating Temp.	0°C~45°C	
Storage Temp.	-20°C~70°C	
Operating Humidity	10%~80%	
Power Consumption	< 2.7W@5V	
Lens Mount	C	

Dimensions	29mm×29 mm×29mm (without lens adapter or connectors)	
Weight	57g	53g
Software	Windows XP/Win7/Win8/Win10 32bit, 64bit OS	
Data Interface	USB3.0	
Programmable Control	Image size, gain, exposure time, trigger polarity, flash polarity	Image size, gain, exposure time
Conformity	CE, RoHS, FCC, USB3 Vision, GenICam	

Table 4-23 MER-230-168U3M(-L) camera specifications

#### 4.14.2. Spectral Response

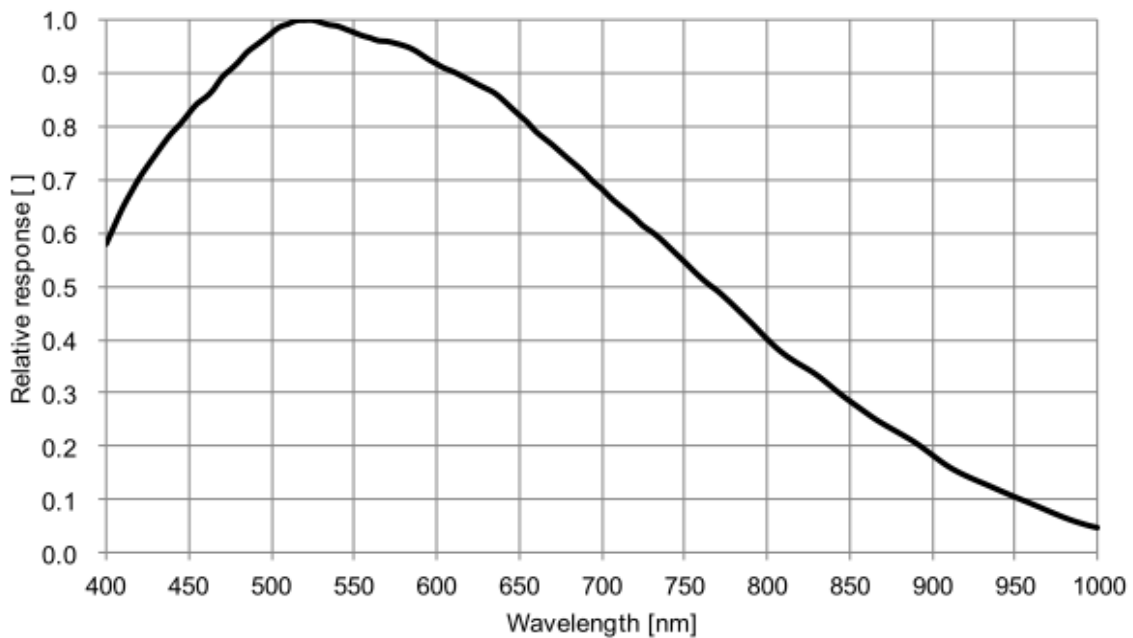

Figure 4-14 MER-230-168U3M(-L) sensor spectral response

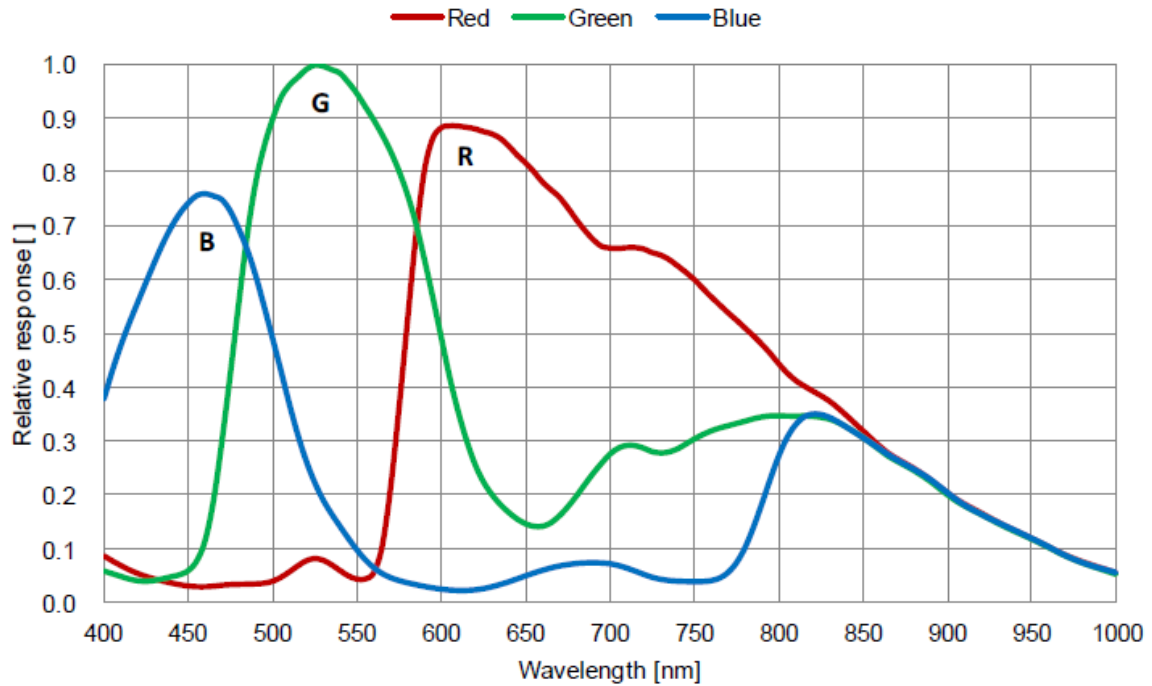

Figure 4-15 MER-230-168U3C(-L) sensor spectral response

## 4.15. MER-231-41U3M/C(-L)

### 4.15.1. Parameter

Specifications	MER-231-41U3C	MER-231-41U3C-L
Resolution	1920× 1200	
Sensor Type	Sony IMX249 global shutter CMOS	
Optical Size	1/1.2 inch	
Pixel Size	5.86μm ×5.86μm	
Frame Rate	41fps@1920× 1200	
ADC Bit Depth	12bit	
Pixel Bit Depth	8bit, 10bit	
Shutter Time	20μs~1s	
Gain	0dB~24dB	
Pixel Data Formats	Bayer RG8/Bayer RG10	

Signal Noise Ratio	45.33dB	
Synchronization	External trigger, software trigger	Software trigger
I/O	1 input and 1 output with opto-isolated, 2 programmable GPIOs	N/A
Operating Temp.	0°C~45°C	
Storage Temp.	-20°C~70°C	
Operating Humidity	10%~80%	
Power Consumption	< 2.7W@5V	
Lens Mount	C	
Dimensions	29mm×29 mm×29mm (without lens adapter or connectors)	
Weight	57g	53g
Software	Windows XP/Win7/Win8/Win10 32bit, 64bit OS	
Data Interface	USB3.0	
Programmable Control	Image size, gain, exposure time, trigger polarity, flash polarity	Image size, gain, exposure time
Conformity	CE, RoHS, FCC, USB3 Vision, GenICam	

Table 4-24 MER-231-41U3C(-L) camera specifications

Specifications	MER-231-41U3M	MER-231-41U3M-L
Resolution	1920× 1200	
Sensor Type	Sony IMX249 global shutter CMOS	
Optical Size	1/1.2 inch	
Pixel Size	5.86μm × 5.86μm	
Frame Rate	41fps@1920×1200	
ADC Bit Depth	12bit	

Pixel Bit Depth	8bit, 10bit	
Shutter Time	20 $\mu$ s~1s	
Gain	0dB~24dB	
Pixel Data Formats	Mono8/Mono10	
Signal Noise Ratio	45.33dB	
Synchronization	External trigger, software trigger	Software trigger
I/O	1 input and 1 output with opto-isolated, 2 programmable GPIOs	N/A
Operating Temp.	0°C~45°C	
Storage Temp.	-20°C~70°C	
Operating Humidity	10%~80%	
Power Consumption	< 2.7W@5V	
Lens Mount	C	
Dimensions	29mm×29 mm×29mm (without lens adapter or connectors)	
Weight	57g	53g
Software	Windows XP/Win7/Win8/Win10 32bit, 64bit OS	
Data Interface	USB3.0	
Programmable Control	Image size, gain, exposure time, trigger polarity, flash polarity	Image size, gain, exposure time
Conformity	CE, RoHS, FCC, USB3 Vision, GenICam	

Table 4-25 MER-231-41U3M(-L) camera specifications

4.15.2. Spectral Response

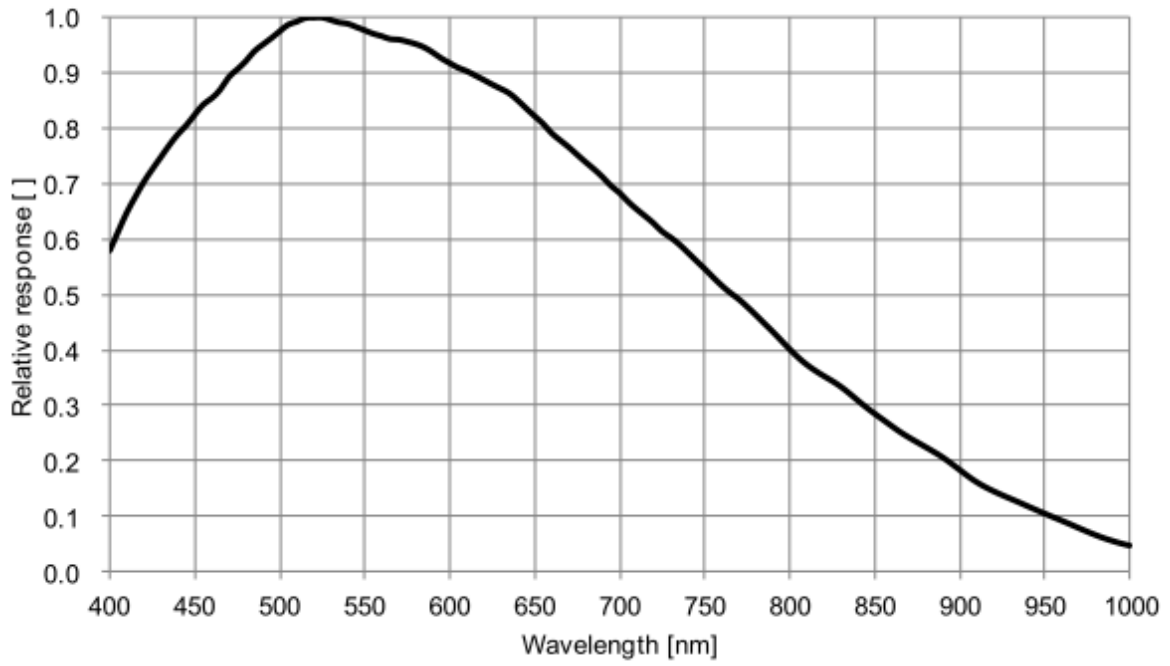

Figure 4-16 MER-231-41U3M(-L) sensor spectral response

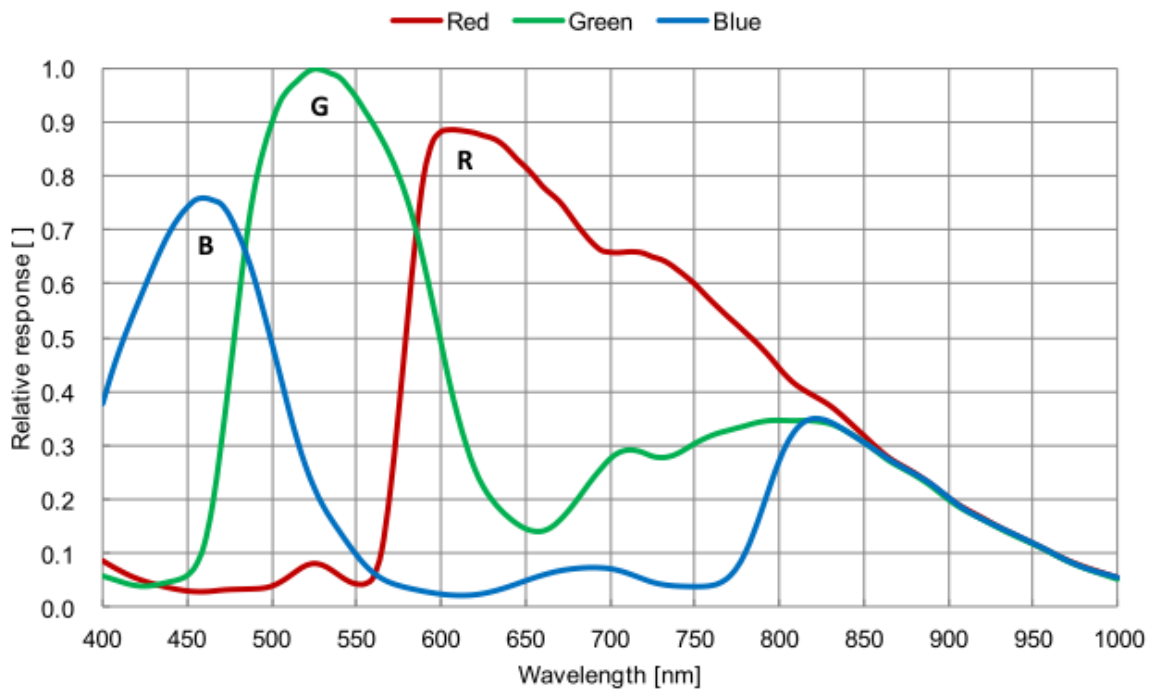

Figure 4-17 MER-231-41U3C(-L) sensor spectral response

## 4.16. MER-301-125U3M/C(-L)

### 4.16.1. Parameter

Specifications	MER-301-125U3C	MER-301-125U3C-L
Resolution	2048×1536	
Sensor Type	Sony IMX252 global shutter CMOS	
Optical Size	1/1.8 inch	
Pixel Size	3.45μm × 3.45μm	
Frame Rate	125fps@2048×1536	
ADC Bit Depth	10bit	
Pixel Bit Depth	8bit, 10bit	
Shutter Time	20μs~1s	
Gain	0dB~24dB	
Pixel Data Formats	Bayer RG8/Bayer RG10	
Signal Noise Ratio	40.75dB	
Synchronization	External trigger, software trigger	Software trigger
I/O	1 input and 1 output with opto-isolated, 2 programmable GPIOs	N/A
Operating Temp.	0°C~45°C	
Storage Temp.	-20°C~70°C	
Operating Humidity	10%~80%	
Power Consumption	< 2.7W@5V	
Lens Mount	C	
Dimensions	29mm×29 mm×29mm (without lens adapter or connectors)	
Weight	57g	53g

Software	Windows XP/Win7/Win8/Win10 32bit, 64bit OS	
Data Interface	USB3.0	
Programmable Control	Image size, gain, exposure time, trigger polarity, flash polarity	Image size, gain, exposure time
Conformity	CE, RoHS, FCC, USB3 Vision, GenICam	

Table 4-26 MER-301-125U3C(-L) camera specifications

Specifications	MER-301-125U3M	MER-301-125U3M-L
Resolution	2048×1536	
Sensor Type	Sony IMX252 global shutter CMOS	
Optical Size	1/1.8 inch	
Pixel Size	3.45μm × 3.45μm	
Frame Rate	125fps@2048×1536	
ADC Bit Depth	10bit	
Pixel Bit Depth	8bit, 10bit	
Shutter Time	20μs~1s	
Gain	0dB~24dB	
Pixel Data Formats	Mono8/Mono10	
Signal Noise Ratio	35dB	
Synchronization	External trigger, software trigger	Software trigger
I/O	1 input and 1 output with opto-isolated, 2 programmable GPIOs	N/A
Operating Temp.	0°C~45°C	
Storage Temp.	-20°C~70°C	
Operating Humidity	10%~80%	



Power Consumption	< 2.7W@5V	
Lens Mount	C	
Dimensions	29mm×29 mm×29mm (without lens adapter or connectors)	
Weight	57g	53g
Software	Windows XP/Win7/Win8/Win10 32bit, 64bit OS	
Data Interface	USB3.0	
Programmable Control	Image size, gain, exposure time, trigger polarity, flash polarity	Image size, gain, exposure time
Conformity	CE, RoHS, FCC, USB3 Vision, GenICam	

Table 4-27 MER-301-125U3M(-L) camera specifications

#### 4.16.2. Spectral Response

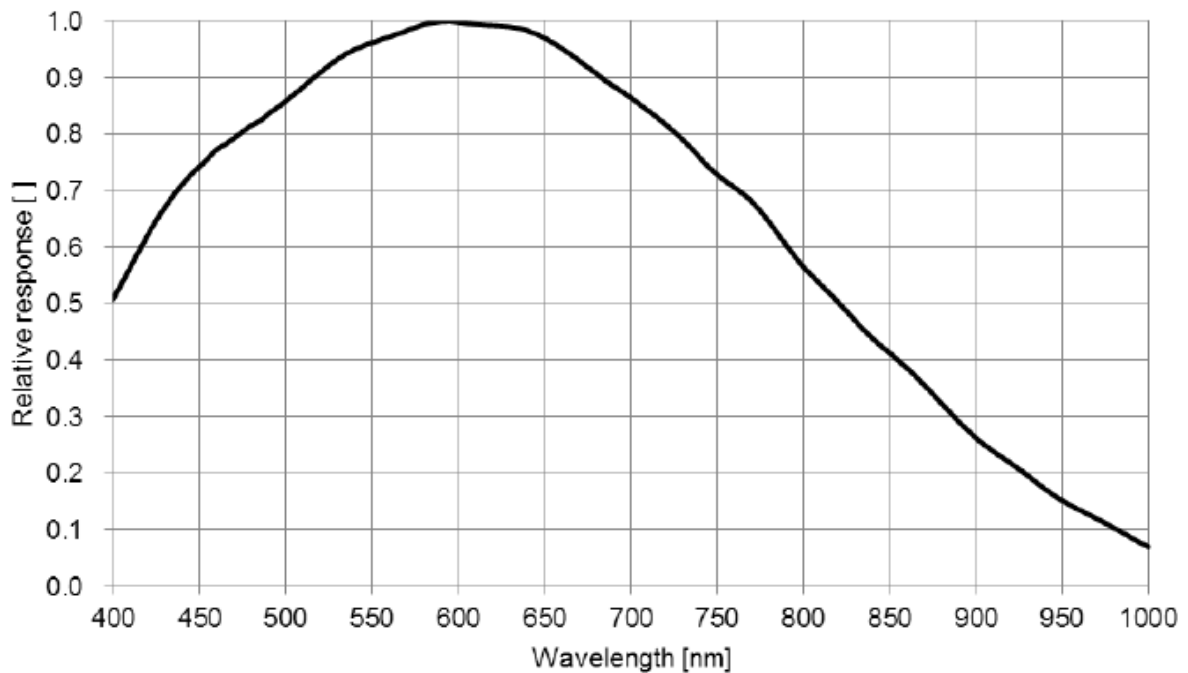

Figure 4-18 MER-301-125U3M(-L) sensor spectral response

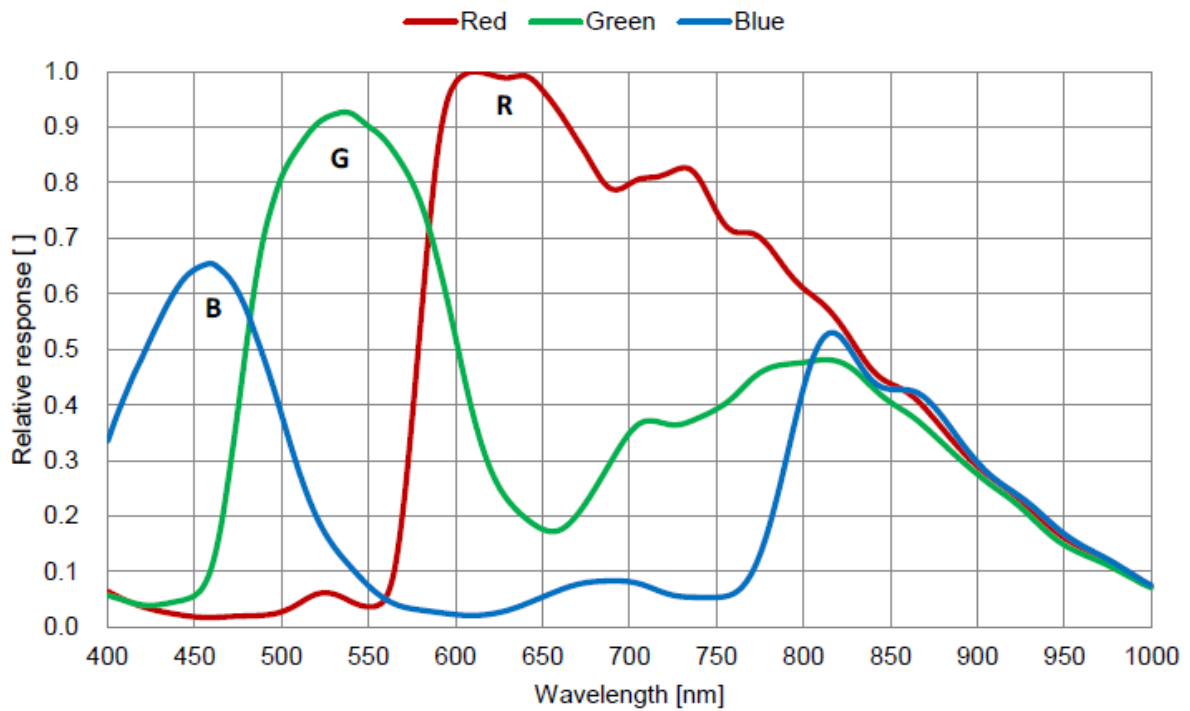

Figure 4-19 MER-301-125U3C(-L) sensor spectral response

## 4.17. MER-302-56U3M/C(-L)

### 4.17.1. Parameter

Specifications	MER-302-56U3C	MER-302-56U3C-L
Resolution	2048×1536	
Sensor Type	Sony IMX265 global shutter CMOS	
Optical Size	1/1.8 inch	
Pixel Size	3.45μm × 3.45μm	
Frame Rate	56fps@2048×1536	
ADC Bit Depth	12bit	
Pixel Bit Depth	8bit, 10bit	
Shutter Time	20μs~1s	
Gain	0dB~24dB	

Pixel Data Formats	Bayer RG8/Bayer RG10	
Signal Noise Ratio	40.09dB	
Synchronization	External trigger, software trigger	Software trigger
I/O	1 input and 1 output with opto-isolated, 2 programmable GPIOs	N/A
Operating Temp.	0°C~45°C	
Storage Temp.	-20°C~70°C	
Operating Humidity	10%~80%	
Power Consumption	< 2.7W@5V	
Lens Mount	C	
Dimensions	29mm×29 mm×29mm (without lens adapter or connectors)	
Weight	57g	53g
Software	Windows XP/Win7/Win8/Win10 32bit, 64bit OS	
Data Interface	USB3.0	
Programmable Control	Image size, gain, exposure time, trigger polarity, flash polarity	Image size, gain, exposure time
Conformity	CE, RoHS, FCC, USB3 Vision, GenICam	

Table 4-28 MER-302-56U3C(-L) camera specifications

Specifications	MER-302-56U3M	MER-302-56U3M-L
Resolution	2048×1536	
Sensor Type	Sony IMX265 global shutter CMOS	
Optical Size	1/1.8 inch	
Pixel Size	3.45μm × 3.45μm	
Frame Rate	56fps@2048×1536	

ADC Bit Depth	12bit	
Pixel Bit Depth	8bit, 10bit	
Shutter Time	20 $\mu$ s~1s	
Gain	0dB~24dB	
Pixel Data Formats	Mono8/Mono10	
Signal Noise Ratio	40.76dB	
Synchronization	External trigger, software trigger	Software trigger
I/O	1 input and 1 output with opto-isolated, 2 programmable GPIOs	N/A
Operating Temp.	0°C~45°C	
Storage Temp.	-20°C~70°C	
Operating Humidity	10%~80%	
Power Consumption	< 2.7W@5V	
Lens Mount	C	
Dimensions	29mm×29 mm×29mm (without lens adapter or connectors)	
Weight	57g	53g
Software	Windows XP/Win7/Win8/Win10 32bit, 64bit OS	
Data Interface	USB3.0	
Programmable Control	Image size, gain, exposure time, trigger polarity, flash polarity	Image size, gain, exposure time
Conformity	CE, RoHS, FCC, USB3 Vision, GenICam	

Table 4-29 MER-302-56U3M(-L) camera specifications

### 4.17.2. Spectral Response

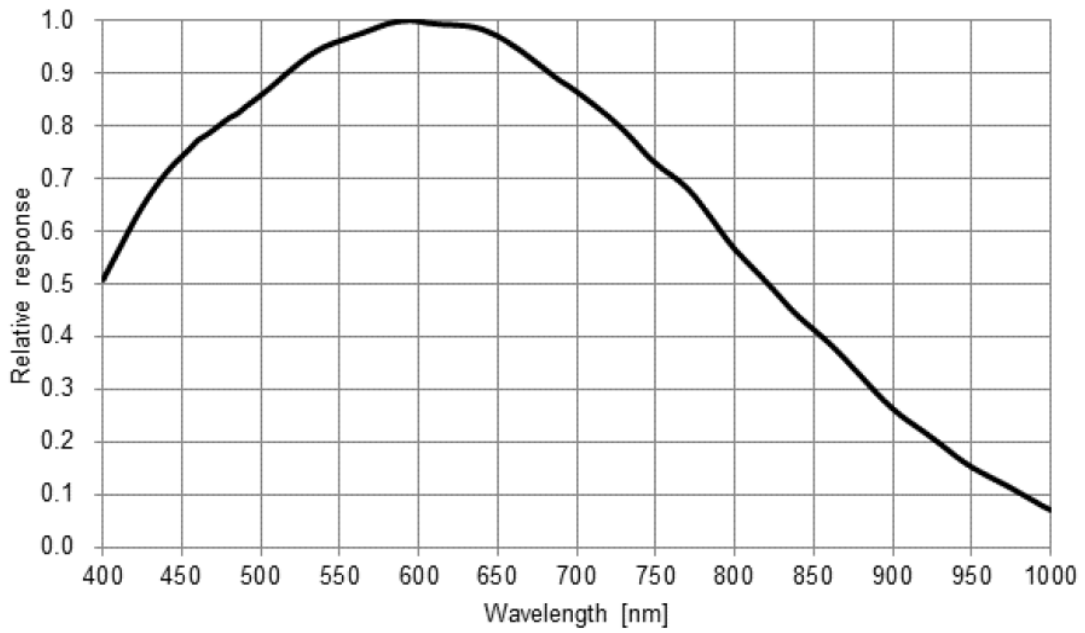

Figure 4-20 MER-302-56U3M(-L) sensor spectral response

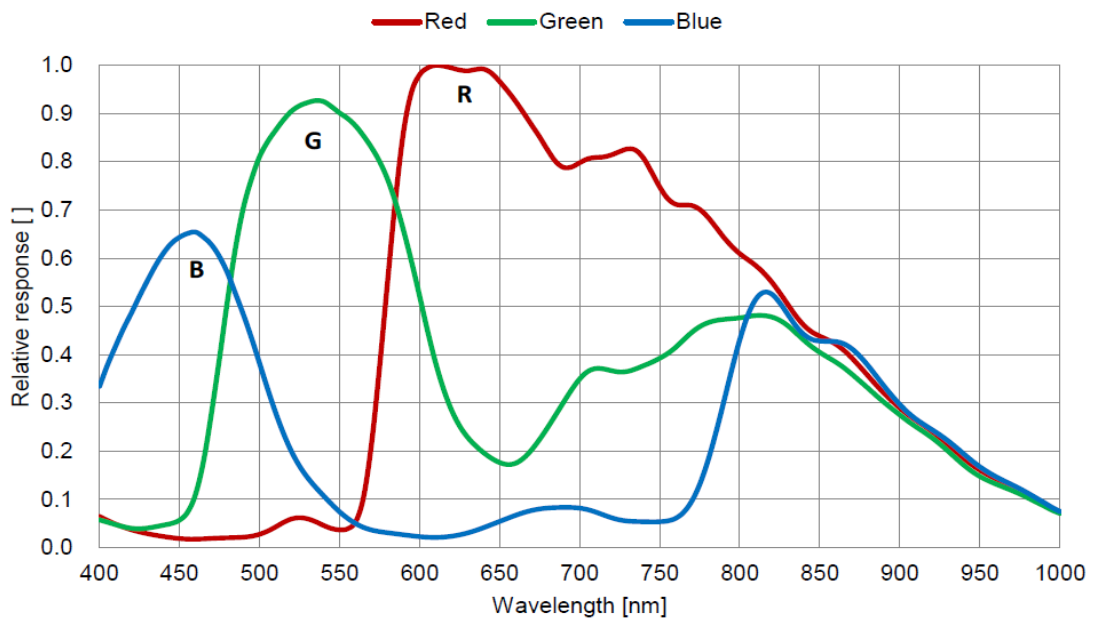

Figure 4-21 MER-302-56U3C(-L) sensor spectral response

## 4.18. MER-500-14U3M/C(-L)

### 4.18.1. Parameter

Specifications	MER-500-14U3C	MER-500-14U3C-L
Resolution	2592x1944	

Sensor Type	Onsemi MT9P006 rolling shutter CMOS	
Optical Size	1/2.5 inch	
Pixel Size	2.2 $\mu$ m $\times$ 2.2 $\mu$ m	
Frame Rate	14fps @ 2592 $\times$ 1944	
ADC Bit Depth	12bit	
Pixel Bit Depth	8bit, 10bit	
Shutter Time	36 $\mu$ s~1s	
Gain	0dB~17dB	
Pixel Data Formats	Bayer GR8/Bayer GR10	
Signal Noise Ratio	35.94dB	
Synchronization	External trigger, software trigger	Software trigger
I/O	1 input and 1 output with opto-isolated, 2 programmable GPIOs	N/A
Operating Temp.	0 $^{\circ}$ C~45 $^{\circ}$ C	
Storage Temp.	-20 $^{\circ}$ C~70 $^{\circ}$ C	
Operating Humidity	10%~80%	
Power Consumption	< 2W@5V	
Lens Mount	C	
Dimensions	29mm $\times$ 29 mm $\times$ 29mm (without lens adapter or connectors)	
Weight	57g	53g
Software	Windows XP/Win7/Win8/Win10 32bit, 64bit OS	
Data Interface	USB3.0	
Programmable Control	Image size, gain, exposure time, trigger polarity, flash polarity	Image size, gain, exposure time

Conformity	CE, RoHS, FCC, USB3 Vision, GenICam
------------	-------------------------------------

Table 4-30 MER-500-14U3C(-L) camera specifications

Specifications	MER-500-14U3M	MER-500-14U3M-L
Resolution	2592×1944	
Sensor Type	Onsemi MT9P031 rolling shutter CMOS	
Optical Size	1/2.5 inch	
Pixel Size	2.2μm × 2.2μm	
Frame Rate	14fps@2592×1944	
ADC Bit Depth	12bit	
Pixel Bit Depth	8bit, 10bit	
Shutter Time	36μs~1s	
Gain	0dB~17dB	
Pixel Data Formats	Mono8/Mono10	
Signal Noise Ratio	35.95dB	
Synchronization	External trigger, software trigger	Software trigger
I/O	1 input and 1 output with opto-isolated, 2 programmable GPIOs	N/A
Operating Temp.	0°C~45°C	
Storage Temp.	-20°C~70°C	
Operating Humidity	10%~80%	
Power Consumption	< 2W@5V	
Lens Mount	C	
Dimensions	29mm×29 mm×29mm (without lens adapter or connectors)	

Weight	57g	53g
Software	Windows XP/Win7/Win8/Win10 32bit, 64bit OS	
Data Interface	USB3.0	
Programmable Control	Image size, gain, exposure time, trigger polarity, flash polarity	Image size, gain, exposure time
Conformity	CE, RoHS, FCC, USB3 Vision, GenICam	

Table 4-31 MER-500-14U3M(-L) camera specifications

#### 4.18.2. Spectral Response

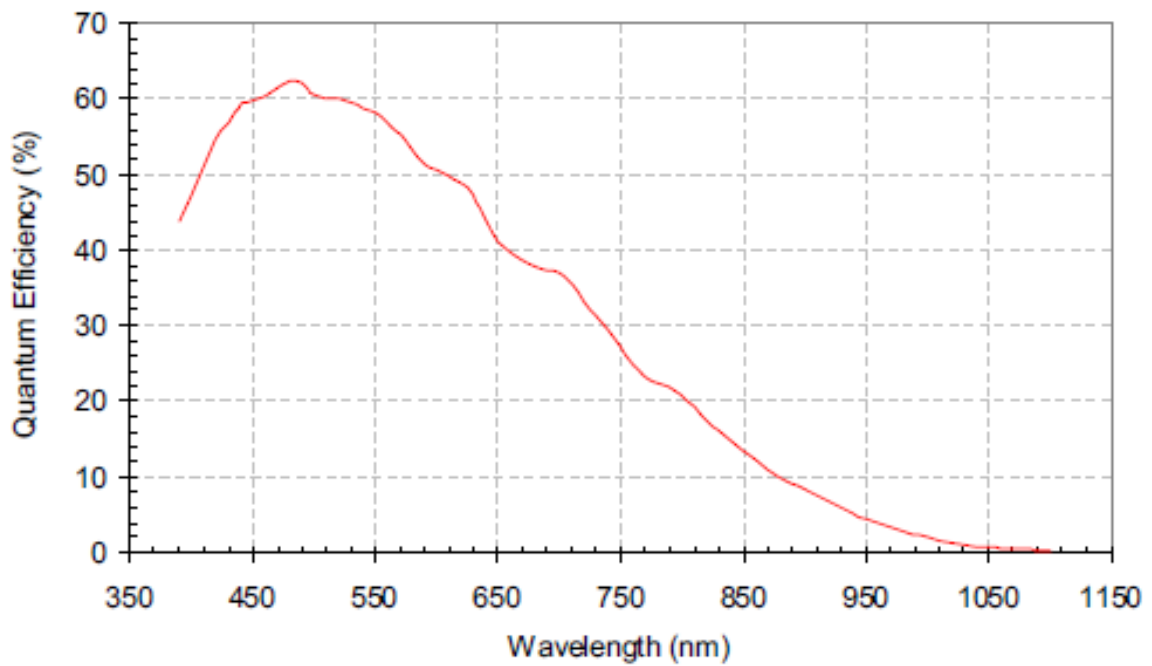

Figure 4-22 MER-500-14U3M(-L) sensor spectral response



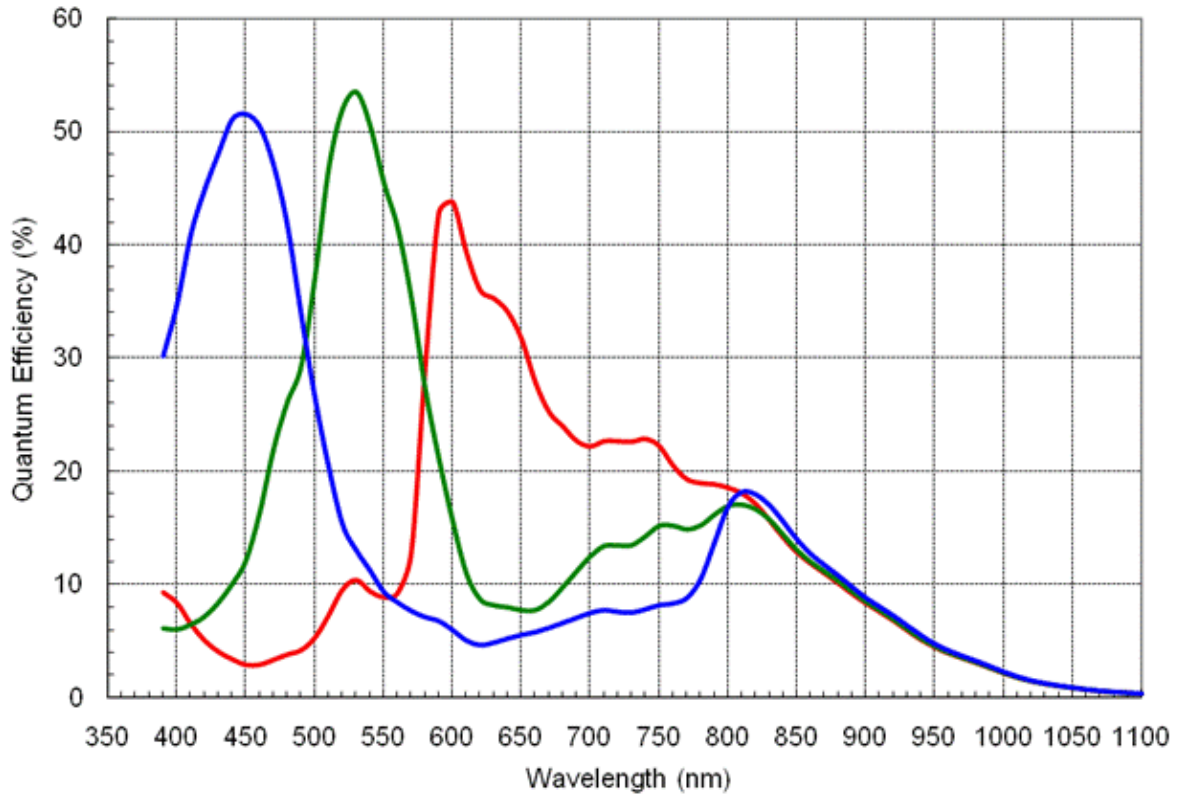

Figure 4-23 MER-500-14U3C(-L) sensor spectral response

### 4.19. MER-502-79U3M/C(-L)

#### 4.19.1. Parameter

Specifications	MER-502-79U3C	MER-502-79U3C-L
Resolution	2448x2048	
Sensor Type	Sony IMX250 global shutter CMOS	
Optical Size	2/3 inch	
Pixel Size	3.45μm × 3.45μm	
Frame Rate	79fps@2448x2048	
ADC Bit Depth	10bit	
Pixel Bit Depth	8bit, 10bit	
Shutter Time	20μs~1s	

Gain	0dB~24dB	
Pixel Data Formats	Bayer RG8/Bayer RG10	
Signal Noise Ratio	40.58dB	
Synchronization	External trigger, software trigger	Software trigger
I/O	1 input and 1 output with opto-isolated, 2 programmable GPIOs	N/A
Operating Temp.	0°C~45°C	
Storage Temp.	-20°C~70°C	
Operating Humidity	10%~80%	
Power Consumption	< 2.7W@5V	
Lens Mount	C	
Dimensions	29mm×29 mm×29mm (without lens adapter or connectors)	
Weight	57g	53g
Software	Windows XP/Win7/Win8/Win10 32bit, 64bit OS	
Data Interface	USB3.0	
Programmable Control	Image size, gain, exposure time, trigger polarity, flash polarity	Image size, gain, exposure time
Conformity	CE, RoHS, FCC, USB3 Vision, GenICam	

Table 4-32 MER-502-79U3C(-L) camera specifications

Specifications	MER-502-79U3M	MER-502-79U3M-L
Resolution	2448×2048	
Sensor Type	Sony IMX250 global shutter CMOS	
Optical Size	2/3 inch	
Pixel Size	3.45μm × 3.45μm	

Frame Rate	79fps@2448x2048	
ADC Bit Depth	10bit	
Pixel Bit Depth	8bit, 10bit	
Shutter Time	20 $\mu$ s~1s	
Gain	0dB~24dB	
Pixel Data Formats	Mono8/Mono10	
Signal Noise Ratio	40.65dB	
Synchronization	External trigger, software trigger	Software trigger
I/O	1 input and 1 output with opto-isolated, 2 programmable GPIOs	N/A
Operating Temp.	0°C~45°C	
Storage Temp.	-20°C~70°C	
Operating Humidity	10%~80%	
Power Consumption	< 2.7W@5V	
Lens Mount	C	
Dimensions	29mmx29 mmx29mm (without lens adapter or connectors)	
Weight	57g	53g
Software	Windows XP/Win7/Win8/Win10 32bit, 64bit OS	
Data Interface	USB3.0	
Programmable Control	Image size, gain, exposure time, trigger polarity, flash polarity	Image size, gain, exposure time
Conformity	CE, RoHS, FCC, USB3 Vision, GenICam	

Table 4-33 MER-502-79U3M(-L) camera specifications

4.19.2. Spectral Response

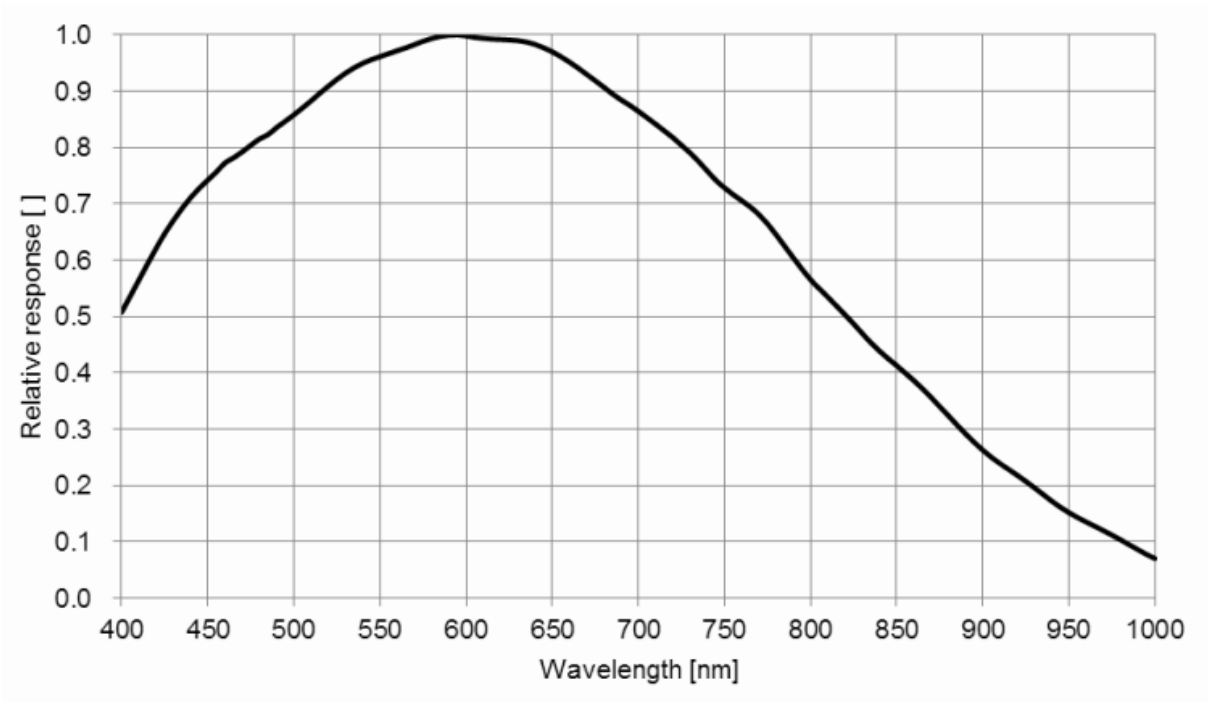

Figure 4-24 MER-502-79U3M(-L) sensor spectral response

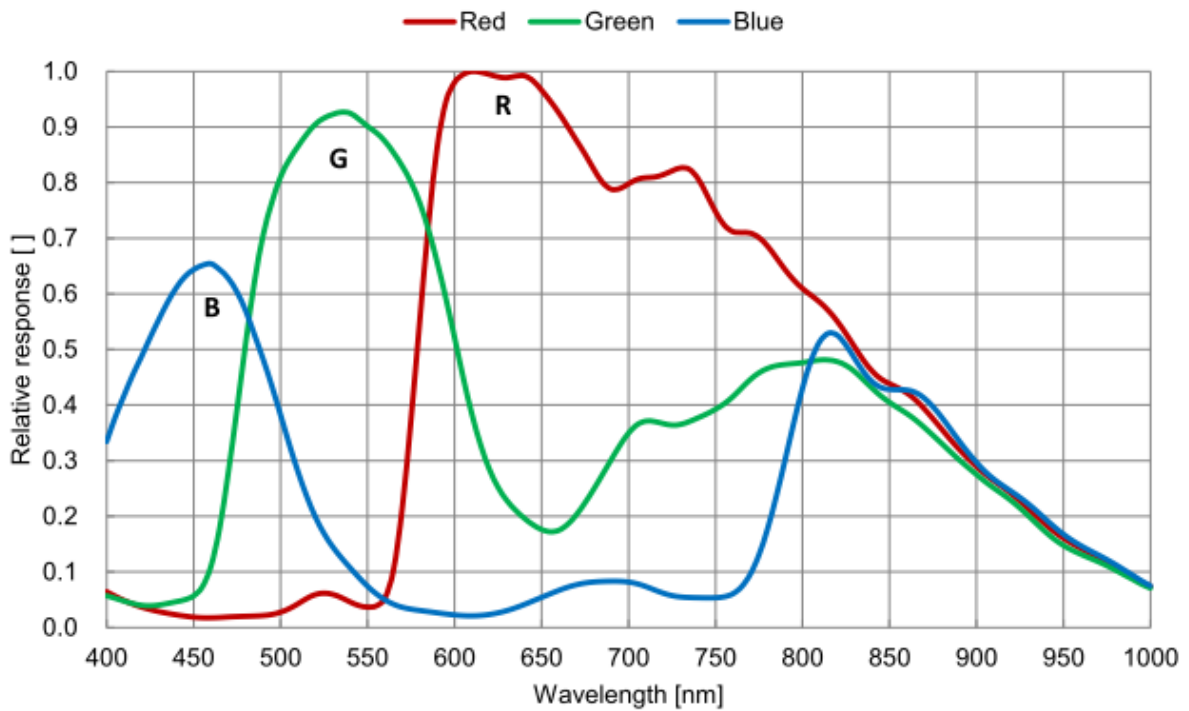

Figure 4-25 MER-502-79U3C(-L) sensor spectral response

## 4.20. MER-502-79U3M(-L) POL

### 4.20.1. Parameter

Specifications	MER-502-79U3M POL	MER-502-79U3M-L POL
Resolution	2448x2048	
Sensor Type	Sony IMX250 global shutter CMOS	
Optical Size	2/3 inch	
Pixel Size	3.45μm × 3.45μm	
Frame Rate	79fps@2448x2048	
ADC Bit Depth	10bit	
Pixel Bit Depth	8bit, 10bit	
Shutter Time	20μs~1s	
Gain	0dB~24dB	
Pixel Data Formats	Mono8/Mono10	
Signal Noise Ratio	41dB	
Synchronization	External trigger, software trigger	Software trigger
I/O	1 input and 1 output with opto-isolated, 2 programmable GPIOs	N/A
Operating Temp.	0°C~45°C	
Storage Temp.	-20°C~70°C	
Operating Humidity	10%~80%	
Power Consumption	< 2.7W@5V	
Lens Mount	C	
Dimensions	29mmx29 mmx29mm (without lens adapter or connectors)	
Weight	57g	53g

Software	Windows XP/Win7/Win8/Win10 32bit, 64bit OS	
Data Interface	USB3.0	
Programmable Control	Image size, gain, exposure time, trigger polarity, flash polarity	Image size, gain, exposure time
Conformity	CE, RoHS, FCC, USB3 Vision, GenICam	

Table 4-34 MER-502-79U3M(-L) POL camera specifications

#### 4.20.2. Spectral Response

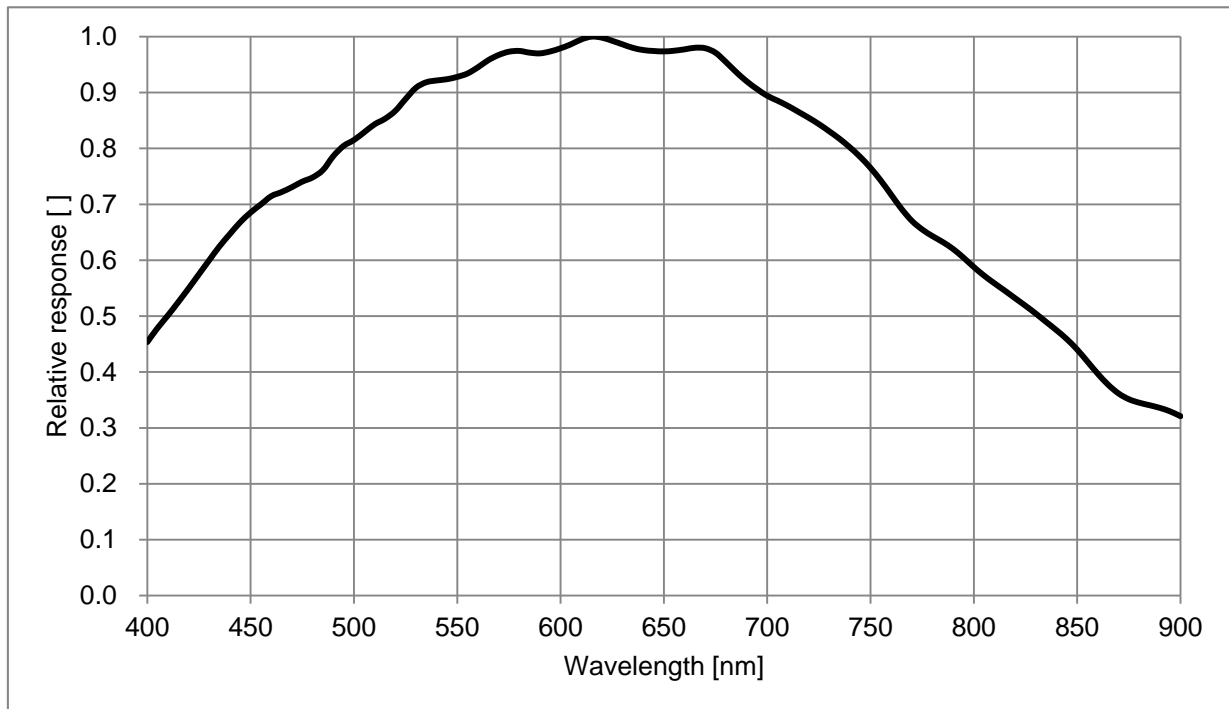

Figure 4-26 MER-502-79U3M(-L) POL sensor spectral response

### 4.21. MER-503-36U3M/C(-L)

#### 4.21.1. Parameter

Specifications	MER-503-36U3C	MER-503-36U3C-L
Resolution	2448x2048	
Sensor Type	Sony IMX264 global shutter CMOS	
Optical Size	2/3 inch	
Pixel Size	3.45μm × 3.45μm	
Frame Rate	36fps@2448x2048	

ADC Bit Depth	12bit	
Pixel Bit Depth	8bit, 10bit	
Shutter Time	20 $\mu$ s~1s	
Gain	0dB~23.9dB	
Pixel Data Formats	Bayer RG8/Bayer RG10	
Signal Noise Ratio	40.58dB	
Synchronization	External trigger, software trigger	Software trigger
I/O	1 input and 1 output with opto-isolated, 2 programmable GPIOs	N/A
Operating Temp.	0°C~45°C	
Storage Temp.	-20°C~70°C	
Operating Humidity	10%~80%	
Power Consumption	< 2.7W@5V	
Lens Mount	C	
Dimensions	29mmx29 mmx29mm (without lens adapter or connectors)	
Weight	57g	53g
Software	Windows XP/Win7/Win8/Win10 32bit, 64bit OS	
Data Interface	USB3.0	
Programmable Control	Image size, gain, exposure time, trigger polarity, flash polarity	Image size, gain, exposure time
Conformity	CE, RoHS, FCC, USB3 Vision, GenICam	

Table 4-35 MER-503-36U3C(-L) camera specifications

Specifications	MER-503-36U3M	MER-503-36U3M-L
Resolution	2448x2048	
Sensor Type	Sony IMX264 global shutter CMOS	
Optical Size	2/3 inch	

Pixel Size	3.45 $\mu$ m $\times$ 3.45 $\mu$ m	
Frame Rate	36fps@2448 $\times$ 2048	
ADC Bit Depth	12bit	
Pixel Bit Depth	8bit, 10bit	
Shutter Time	20 $\mu$ s~1s	
Gain	0dB~23.9dB	
Pixel Data Formats	Mono8/Mono10	
Signal Noise Ratio	39dB	
Synchronization	External trigger, software trigger	Software trigger
I/O	1 input and 1 output with opto-isolated, 2 programmable GPIOs	N/A
Operating Temp.	0 $^{\circ}$ C~45 $^{\circ}$ C	
Storage Temp.	-20 $^{\circ}$ C~70 $^{\circ}$ C	
Operating Humidity	10%~80%	
Power Consumption	< 2.7W@5V	
Lens Mount	C	
Dimensions	29mm $\times$ 29 mm $\times$ 29mm (without lens adapter or connectors)	
Weight	57g	53g
Software	Windows XP/Win7/Win8/Win10 32bit, 64bit OS	
Data Interface	USB3.0	
Programmable Control	Image size, gain, exposure time, trigger polarity, flash polarity	Image size, gain, exposure time
Conformity	CE, RoHS, FCC, USB3 Vision, GenICam	

Table 4-36 MER-503-36U3M(-L) camera specifications



4.21.2. Spectral Response

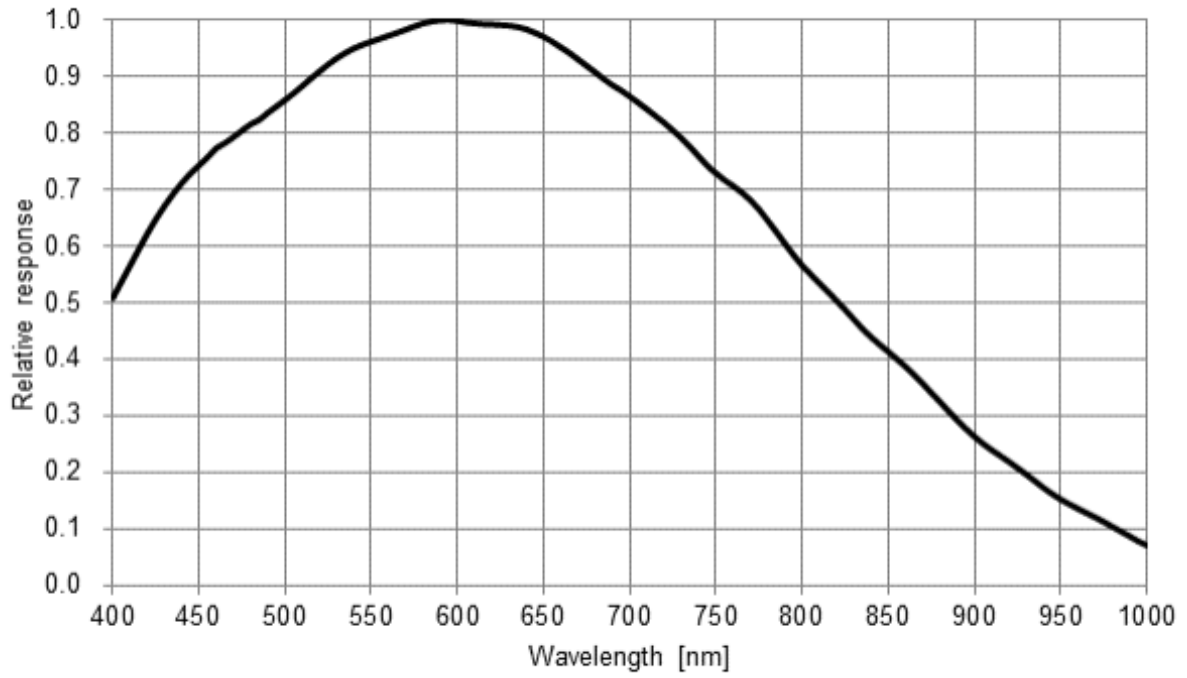

Figure 4-27 MER-503-36U3M(-L) sensor spectral response

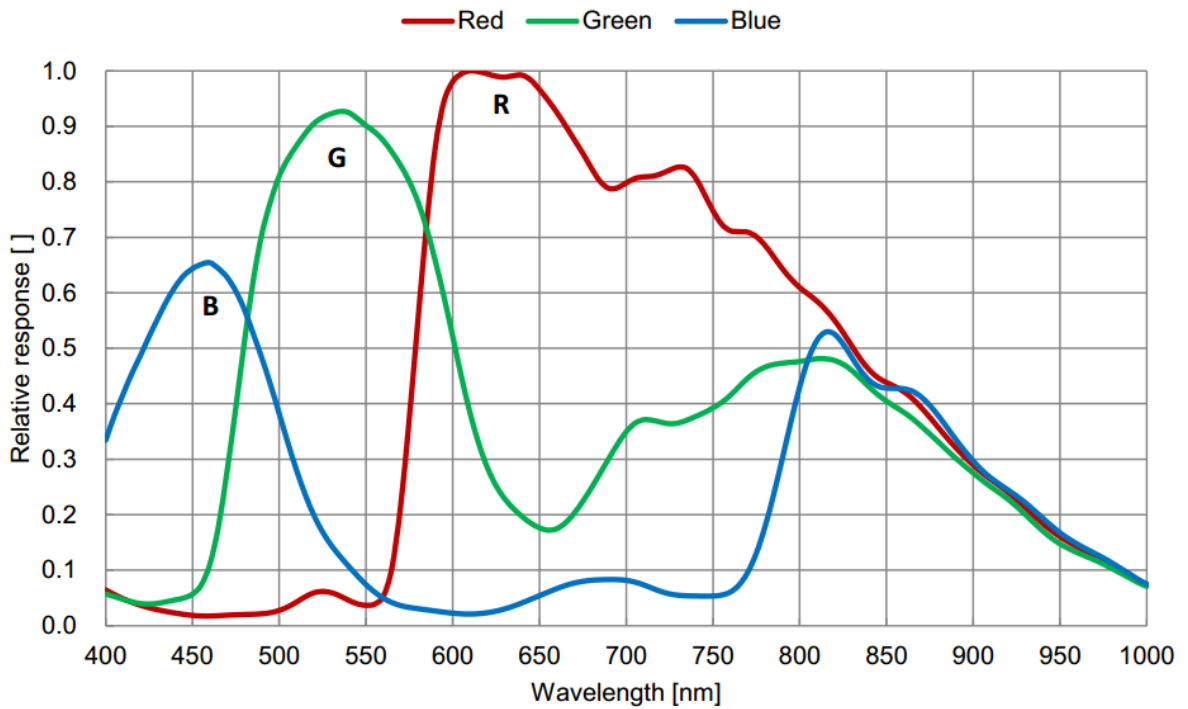

Figure 4-28 MER-503-36U3C(-L) sensor spectral response

## 4.22. MER-630-60U3M/C(-L)

### 4.22.1. Parameter

Specifications	MER-630-60U3C	MER-630-60U3C-L
Resolution	3088x2064	
Sensor Type	Sony IMX178 rolling shutter CMOS	
Optical Size	1/1.8 inch	
Pixel Size	2.4μm × 2.4μm	
Frame Rate	60fps@3088x2064	
ADC Bit Depth	10bit	
Pixel Bit Depth	8bit, 10bit	
Shutter Time	8μs~1s	
Gain	0dB~24dB	
Pixel Data Formats	Bayer RG8/Bayer RG10	
Signal Noise Ratio	40.19dB	
Synchronization	External trigger, software trigger	Software trigger
I/O	1 input and 1 output with opto-isolated, 2 programmable GPIOs	N/A
Operating Temp.	0°C~45°C	
Storage Temp.	-20°C~70°C	
Operating Humidity	10%~80%	
Power Consumption	< 2.7W@5V	
Lens Mount	C	
Dimensions	29mmx29 mmx29mm (without lens adapter or connectors)	
Weight	57g	53g

Software	Windows XP/Win7/Win8/Win10 32bit, 64bit OS	
Data Interface	USB3.0	
Programmable Control	Image size, gain, exposure time, trigger polarity, flash polarity	Image size, gain, exposure time
Conformity	CE, RoHS, FCC, USB3 Vision, GenICam	

Table 4-37 MER-630-60U3C(-L) camera specifications

Specifications	MER-630-60U3M	MER-630-60U3M-L
Resolution	3088×2064	
Sensor Type	Sony IMX178 rolling shutter CMOS	
Optical Size	1/1.8 inch	
Pixel Size	2.4μm × 2.4μm	
Frame Rate	60fps@3088×2064	
ADC Bit Depth	10bit	
Pixel Bit Depth	8bit, 10bit	
Shutter Time	8μs~1s	
Gain	0dB~24dB	
Pixel Data Formats	Mono8/Mono10	
Signal Noise Ratio	40.18dB	
Synchronization	External trigger, software trigger	Software trigger
I/O	1 input and 1 output with opto-isolated, 2 programmable GPIOs	N/A
Operating Temp.	0°C~45°C	
Storage Temp.	-20°C~70°C	
Operating Humidity	10%~80%	

Power Consumption	< 2.7W@5V	
Lens Mount	C	
Dimensions	29mm×29 mm×29mm (without lens adapter or connectors)	
Weight	57g	53g
Software	Windows XP/Win7/Win8/Win10 32bit, 64bit OS	
Data Interface	USB3.0	
Programmable Control	Image size, gain, exposure time, trigger polarity, flash polarity	Image size, gain, exposure time
Conformity	CE, RoHS, FCC, USB3 Vision, GenICam	

Table 4-38 MER-630-60U3M(-L) camera specifications

#### 4.22.2. Spectral Response

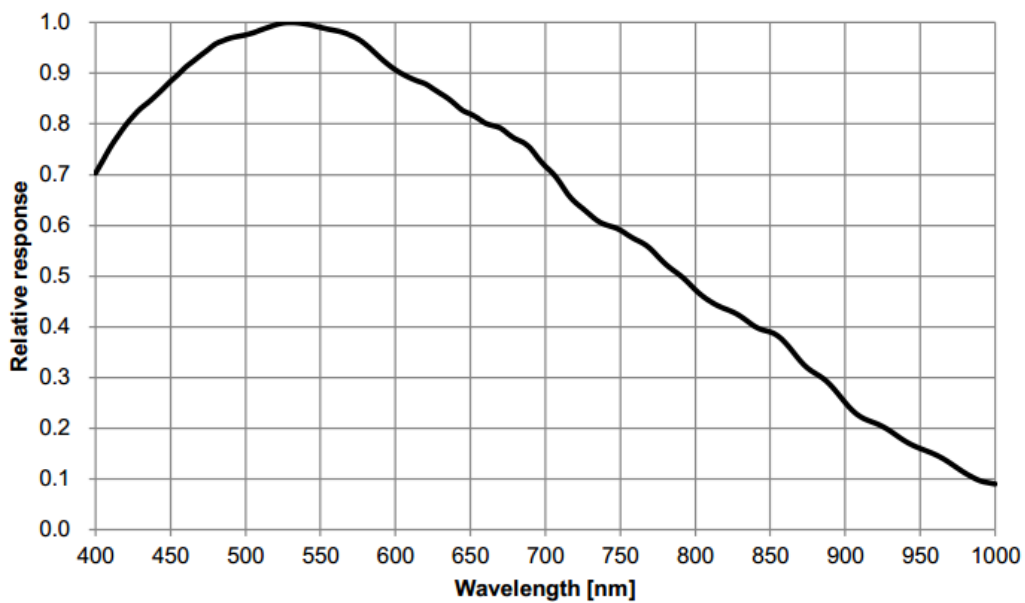

Figure 4-29 MER-630-60U3M(-L) sensor spectral response

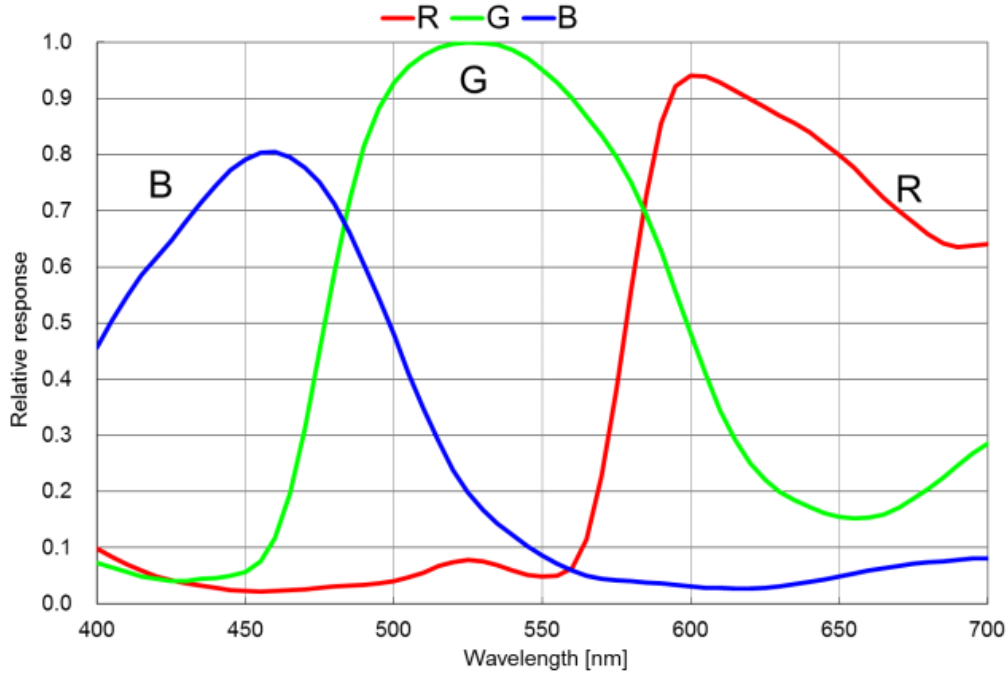

Figure 4-30 MER-630-60U3C(-L) sensor spectral response

## 4.23. MER-1070-14U3M/C(-L)

### 4.23.1. Parameter

Specifications	MER-1070-14U3C	MER-1070-14U3C-L
Resolution	3840x2748	
Sensor Type	Onsemi MT9J003 rolling shutter CMOS	
Optical Size	1/2.3 inch	
Pixel Size	1.67μm × 1.67μm	
Frame Rate	14fps@3840x2748	
ADC Bit Depth	12bit	
Pixel Bit Depth	8bit, 12bit	
Shutter Time	24μs~1s	
Gain	0dB~25.9dB	
Pixel Data Formats	Bayer GR8/Bayer GR12	

Signal Noise Ratio	36.16dB	
Synchronization	External trigger, software trigger	Software trigger
I/O	1 input and 1 output with opto-isolated, 2 programmable GPIOs	N/A
Operating Temp.	0°C~45°C	
Storage Temp.	-20°C~70°C	
Operating Humidity	10%~80%	
Power Consumption	< 2.7W@5V	
Lens Mount	C	
Dimensions	29mm×29 mm×29mm (without lens adapter or connectors)	
Weight	57g	53g
Software	Windows XP/Win7/Win8/Win10 32bit, 64bit OS	
Data Interface	USB3.0	
Programmable Control	Image size, gain, exposure time, trigger polarity, flash polarity	Image size, gain, exposure time
Conformity	CE, RoHS, FCC, USB3 Vision, GenICam	

Table 4-39 MER-1070-14U3C(-L) camera specifications

Specifications	MER-1070-14U3M	MER-1070-14U3M-L
Resolution	3840×2748	
Sensor Type	Onsemi MT9J003 rolling shutter CMOS	
Optical Size	1/2.3 inch	
Pixel Size	1.67μm ×1.67μm	
Frame Rate	14fps@3840×2748	
ADC Bit Depth	12bit	

Pixel Bit Depth	8bit, 12bit	
Shutter Time	24 $\mu$ s~1s	
Gain	0dB~25.9dB	
Pixel Data Formats	Mono8/Mono12	
Signal Noise Ratio	35.89dB	
Synchronization	External trigger, software trigger	Software trigger
I/O	1 input and 1 output with opto-isolated, 2 programmable GPIOs	N/A
Operating Temp.	0°C~45°C	
Storage Temp.	-20°C~70°C	
Operating Humidity	10%~80%	
Power Consumption	< 2.7W@5V	
Lens Mount	C	
Dimensions	29mm×29 mm×29mm (without lens adapter or connectors)	
Weight	57g	53g
Software	Windows XP/Win7/Win8/Win10 32bit, 64bit OS	
Data Interface	USB3.0	
Programmable Control	Image size, gain, exposure time, trigger polarity, flash polarity	Image size, gain, exposure time
Conformity	CE, RoHS, FCC, USB3 Vision, GenICam	

Table 4-40 MER-1070-14U3M(-L) camera specifications

4.23.2. Spectral Response

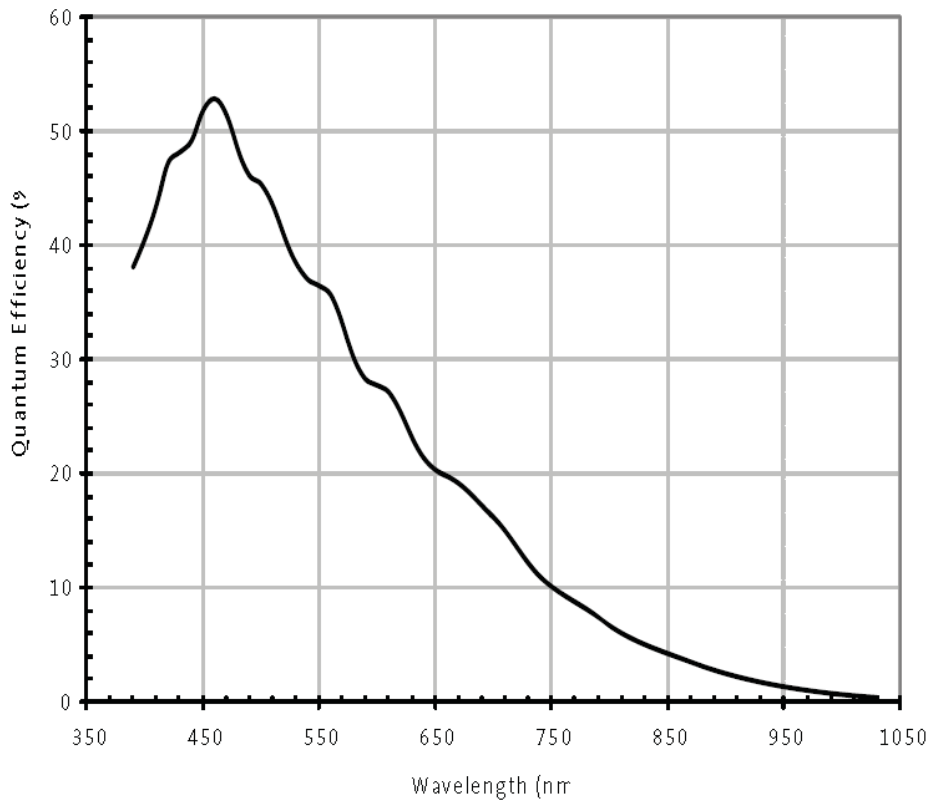

Figure 4-31 MER-1070-14U3M(-L) sensor spectral response

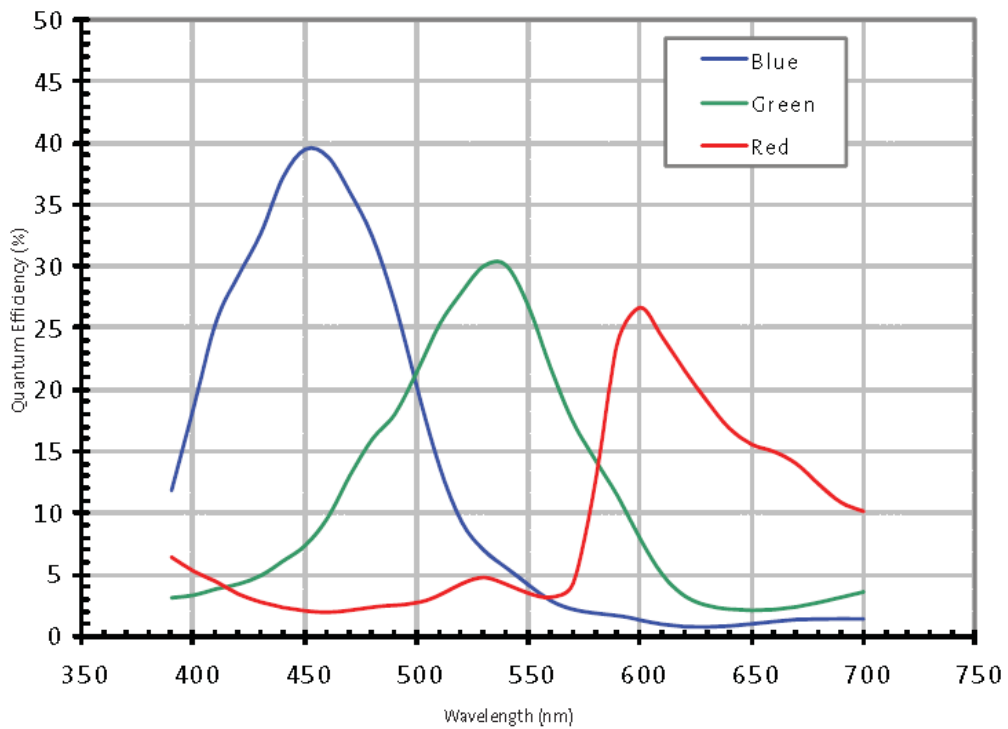

Figure 4-32 MER-1070-14U3C(-L) sensor spectral response



## 4.24. MER-1220-32U3M/C(-L)

### 4.24.1. Parameter

Specifications	MER-1220-32U3C	MER-1220-32U3C-L
Resolution	4024 × 3036	
Sensor Type	Sony IMX226 rolling shutter CMOS	
Optical Size	1/1.7 inch	
Pixel Size	1.85μm × 1.85μm	
Frame Rate	32.3fps@4024 × 3036	
ADC Bit Depth	12bit	
Pixel Bit Depth	8bit, 12bit	
Shutter Time	10μs~1s	
Gain	0dB~24dB	
Pixel Data Formats	Bayer RG8/Bayer RG12	
Signal Noise Ratio	41dB	
Synchronization	External trigger, software trigger	Software trigger
I/O	1 input and 1 output with opto-isolated, 2 programmable GPIOs	N/A
Operating Temp.	0°C~45°C	
Storage Temp.	-20°C~70°C	
Operating Humidity	10%~80%	
Power Consumption	< 2.7W@5V	
Lens Mount	C	
Dimensions	29mm×29 mm×29mm (without lens adapter or connectors)	
Weight	57g	53g

Software	Windows XP/Win7/Win8/Win10 32bit, 64bit OS	
Data Interface	USB3.0	
Programmable Control	Image size, gain, exposure time, trigger polarity, flash polarity	Image size, gain, exposure time
Conformity	CE, RoHS, FCC, USB3 Vision, GenICam	

Table 4-41 MER-1220-32U3C(-L) camera specifications

Specifications	MER-1220-32U3M	MER-1220-32U3M-L
Resolution	4024 × 3036	
Sensor Type	Sony IMX226 rolling shutter CMOS	
Optical Size	1/1.7 inch	
Pixel Size	1.85μm × 1.85μm	
Frame Rate	32.3fps @ 4024 × 3036	
ADC Bit Depth	12bit	
Pixel Bit Depth	8bit, 12bit	
Shutter Time	10μs~1s	
Gain	0dB~24dB	
Pixel Data Formats	Mono8/Mono12	
Signal Noise Ratio	41dB	
Synchronization	External trigger, software trigger	Software trigger
I/O	1 input and 1 output with opto-isolated, 2 programmable GPIOs	N/A
Operating Temp.	0°C~45°C	
Storage Temp.	-20°C~70°C	
Operating Humidity	10%~80%	

Power Consumption	< 2.7W@5V	
Lens Mount	C	
Dimensions	29mm×29 mm×29mm (without lens adapter or connectors)	
Weight	57g	53g
Software	Windows XP/Win7/Win8/Win10 32bit, 64bit OS	
Data Interface	USB3.0	
Programmable Control	Image size, gain, exposure time, trigger polarity, flash polarity	Image size, gain, exposure time
Conformity	CE, RoHS, FCC, USB3 Vision, GenICam	

Table 4-42 MER-1220-32U3M(-L) camera specifications

#### 4.24.2. Spectral Response

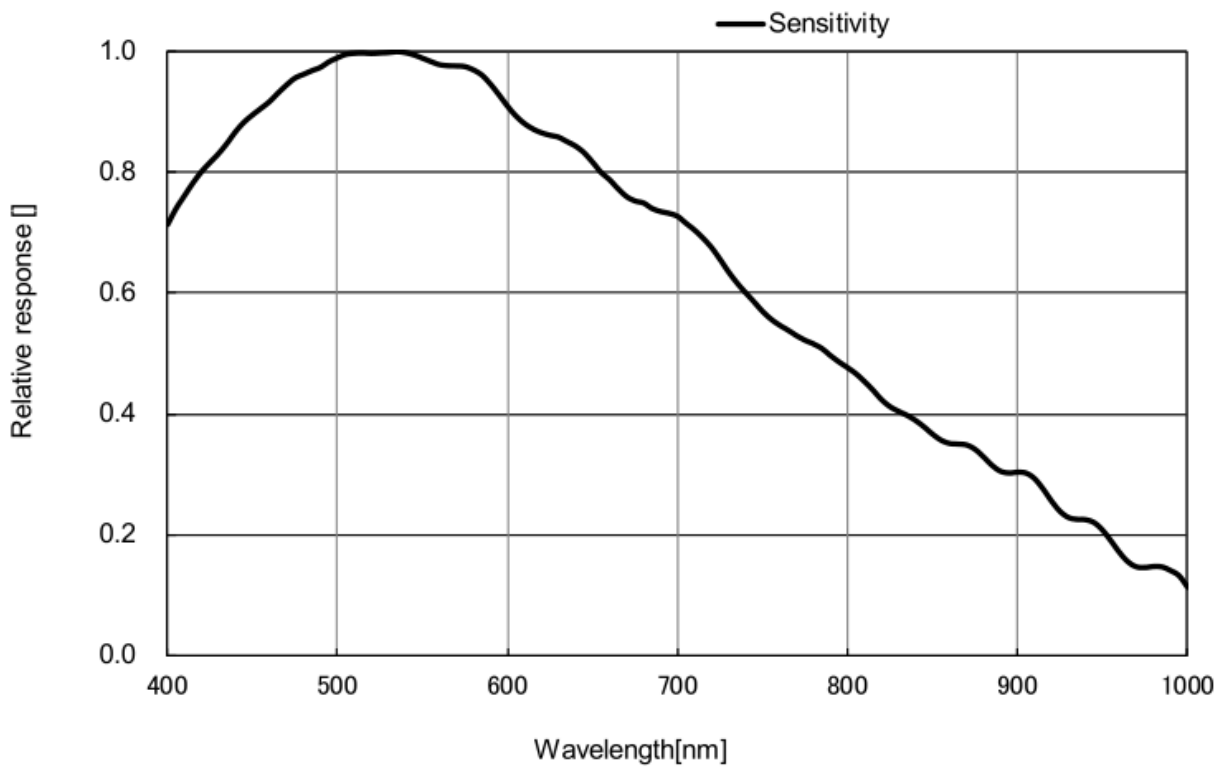

Figure 4-33 MER-1220-32U3M(-L) sensor spectral response

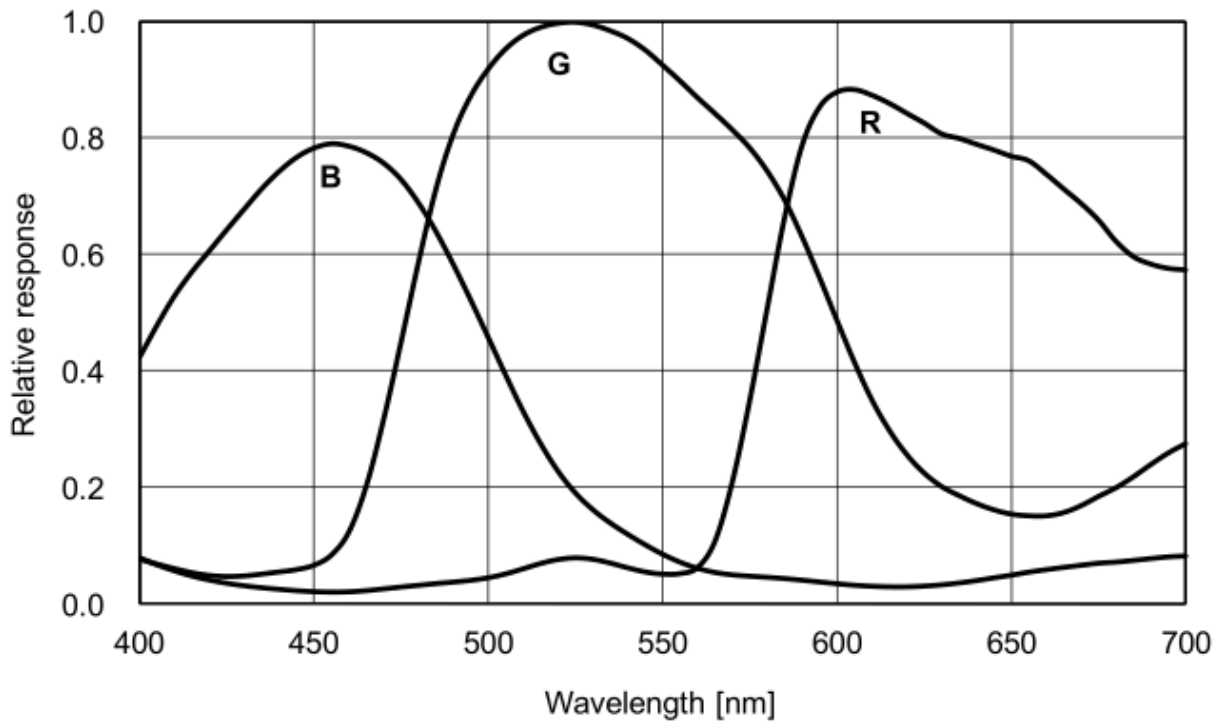

Figure 4-34 MER-1220-32U3C(-L) sensor spectral response

## 4.25. MER-1520-13U3C(-L)

### 4.25.1. Parameter

Specifications	MER-1520-13U3C	MER-1520-13U3C-L
Resolution	4608x3288	
Sensor Type	Onsemi MT9F002 rolling shutter CMOS	
Optical Size	1/2.3 inch	
Pixel Size	1.4μm × 1.4μm	
Frame Rate	13fps @ 4608x3288	
ADC Bit Depth	12bit	
Pixel Bit Depth	8bit, 12bit	
Shutter Time	22μs~1s	
Gain	0dB~22.5dB	

Pixel Data Formats	Bayer GR8/Bayer GR12	
Signal Noise Ratio	35.36dB	
Synchronization	External trigger, software trigger	Software trigger
I/O	1 input and 1 output with opto-isolated, 2 programmable GPIOs	N/A
Operating Temp.	0°C~45°C	
Storage Temp.	-20°C~70°C	
Operating Humidity	10%~80%	
Power Consumption	2.7W@5V	
Lens Mount	C	
Dimensions	29mm×29 mm×29mm (without lens adapter or connectors)	
Weight	57g	53g
Software	Windows XP/Win7/Win8/Win10 32bit, 64bit OS	
Data Interface	USB3.0	
Programmable Control	Image size, gain, exposure time, trigger polarity, flash polarity	Image size, gain, exposure time
Conformity	CE, RoHS, FCC, USB3 Vision, GenICam	

Table 4-43 MER-1520-13U3C(-L) camera specifications

### 4.25.2. Spectral Response

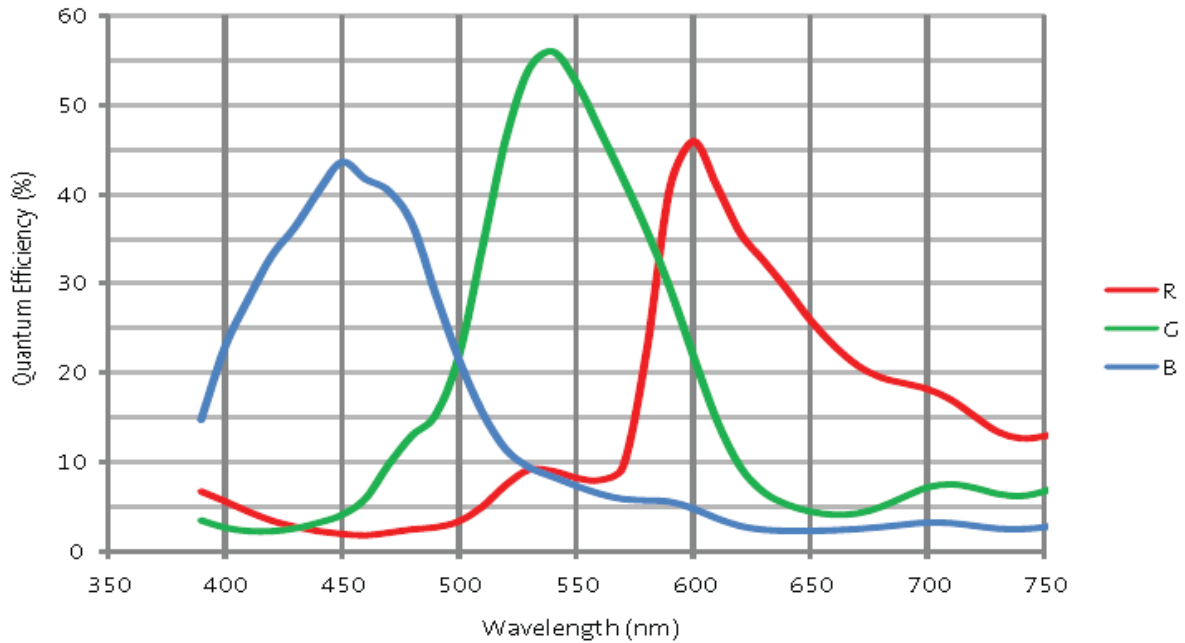

Figure 4-35 MER-1520-13U3C(-L) sensor spectral response

## 4.26. MER-1810-21U3C(-L)

### 4.26.1. Parameter

Specifications	MER-1810-21U3C	MER-1810-21U3C-L
Resolution	4912×3684	
Sensor Type	Onsemi AR1820 rolling shutter CMOS	
Optical Size	1/2.3 inch	
Pixel Size	1.25μm ×1.25μm	
Frame Rate	21fps@4912×3684	
ADC Bit Depth	12bit	
Pixel Bit Depth	8bit, 12bit	
Shutter Time	20μs~1s	
Gain	0dB~20dB	
Pixel Data Formats	Bayer GR8/Bayer GR12	

Signal Noise Ratio	37.39dB	
Synchronization	External trigger, software trigger	Software trigger
I/O	1 input and 1 output with opto-isolated, 2 programmable GPIOs	N/A
Operating Temp.	0°C~45°C	
Storage Temp.	-20°C~70°C	
Operating Humidity	10%~80%	
Power Consumption	< 2.7W@5V	
Lens Mount	C	
Dimensions	29mm×29 mm×29mm (without lens adapter or connectors)	
Weight	57g	53g
Software	Windows XP/Win7/Win8/Win10 32bit, 64bit OS	
Data Interface	USB3.0	
Programmable Control	Image size, gain, exposure time, trigger polarity, flash polarity	Image size, gain, exposure time
Conformity	CE, RoHS, FCC, USB3 Vision, GenICam	

Table 4-44 MER-1810-21U3C(-L) camera specifications

4.26.2. Spectral Response

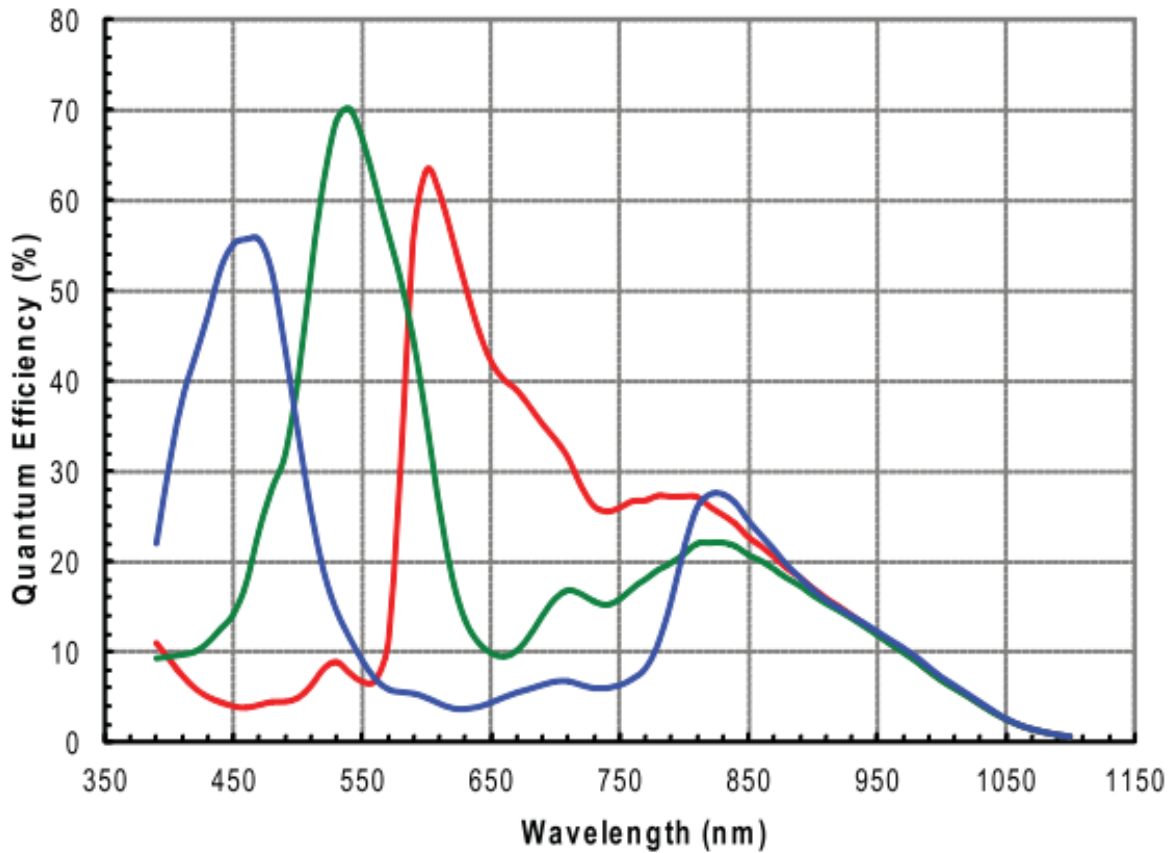

Figure 4-36 MER-1810-21U3C(-L) sensor spectral response

4.27. MER-2000-19U3M/C(-L)

4.27.1. Parameter

Specifications	MER-2000-19U3C	MER-2000-19U3C-L
Resolution	5496x3672	
Sensor Type	Sony IMX183 rolling shutter CMOS	
Optical Size	1 inch	
Pixel Size	2.4μm × 2.4μm	
Frame Rate	19.6fps@5496x3672	
ADC Bit Depth	12bit	
Pixel Bit Depth	8bit, 12bit	



Shutter Time	12 $\mu$ s~1s	
Gain	0dB~24dB	
Pixel Data Formats	Bayer RG8/Bayer RG12	
Signal Noise Ratio	42dB	
Synchronization	External trigger, software trigger	Software trigger
I/O	1 input and 1 output with opto-isolated, 2 programmable GPIOs	N/A
Operating Temp.	0°C~45°C	
Storage Temp.	-20°C~70°C	
Operating Humidity	10%~80%	
Power Consumption	< 2.7W@5V	
Lens Mount	C	
Dimensions	29mm×29 mm×29mm (without lens adapter or connectors)	
Weight	57g	53g
Software	Windows XP/Win7/Win8/Win10 32bit, 64bit OS	
Data Interface	USB3.0	
Programmable Control	Image size, gain, exposure time, trigger polarity, flash polarity	Image size, gain, exposure time
Conformity	CE, RoHS, FCC, USB3 Vision, GenICam	

Table 4-45 MER-2000-19U3C(-L) camera specifications

Specifications	MER-2000-19U3M	MER-2000-19U3M-L
Resolution	5496×3672	
Sensor Type	Sony IMX183 rolling shutter CMOS	
Optical Size	1 inch	

Pixel Size	2.4 $\mu$ m $\times$ 2.4 $\mu$ m	
Frame Rate	19.6fps@5496 $\times$ 3672	
ADC Bit Depth	12bit	
Pixel Bit Depth	8bit, 12bit	
Shutter Time	12 $\mu$ s~1s	
Gain	0dB~24dB	
Pixel Data Formats	Mono8/Mono12	
Signal Noise Ratio	42dB	
Synchronization	External trigger, software trigger	Software trigger
I/O	1 input and 1 output with opto-isolated, 2 programmable GPIOs	N/A
Operating Temp.	0 $^{\circ}$ C~45 $^{\circ}$ C	
Storage Temp.	-20 $^{\circ}$ C~70 $^{\circ}$ C	
Operating Humidity	10%~80%	
Power Consumption	< 2.7W@5V	
Lens Mount	C	
Dimensions	29mm $\times$ 29 mm $\times$ 29mm (without lens adapter or connectors)	
Weight	57g	53g
Software	Windows XP/Win7/Win8/Win10 32bit, 64bit OS	
Data Interface	USB3.0	
Programmable Control	Image size, gain, exposure time, trigger polarity, flash polarity	Image size, gain, exposure time
Conformity	CE, RoHS, FCC, USB3 Vision, GenICam	

Table 4-46 MER-2000-19U3M(-L) camera specifications

4.27.2. Spectral Response

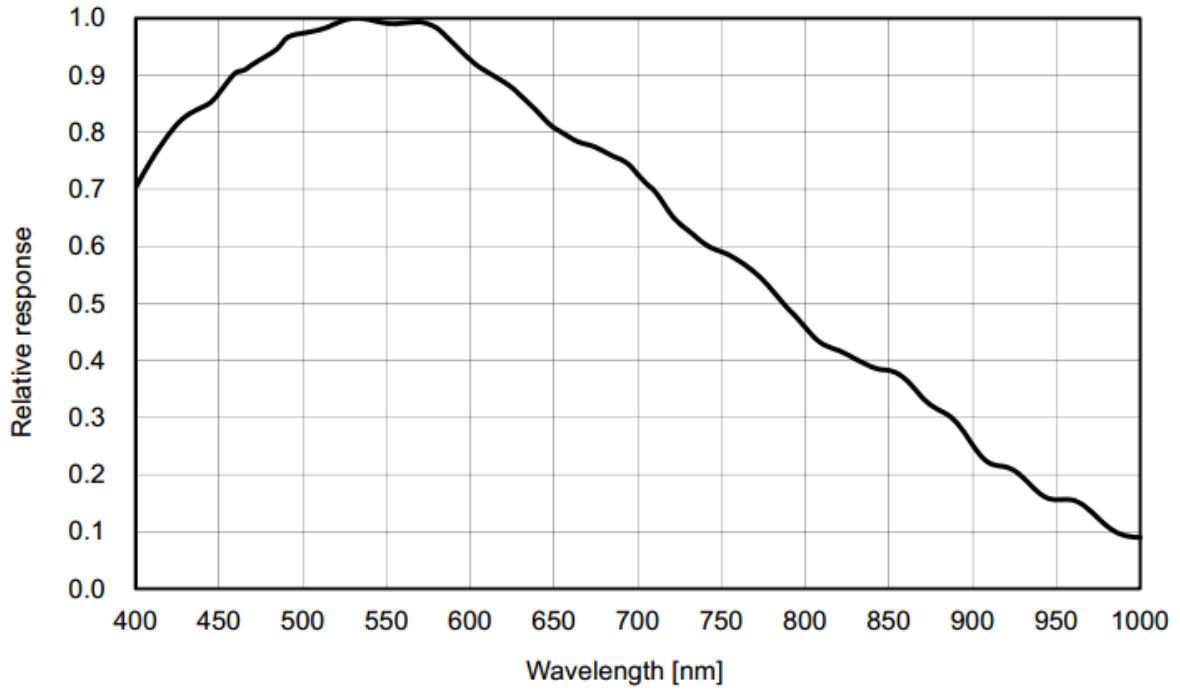

Figure 4-37 MER-2000-19U3M(-L) sensor spectral response

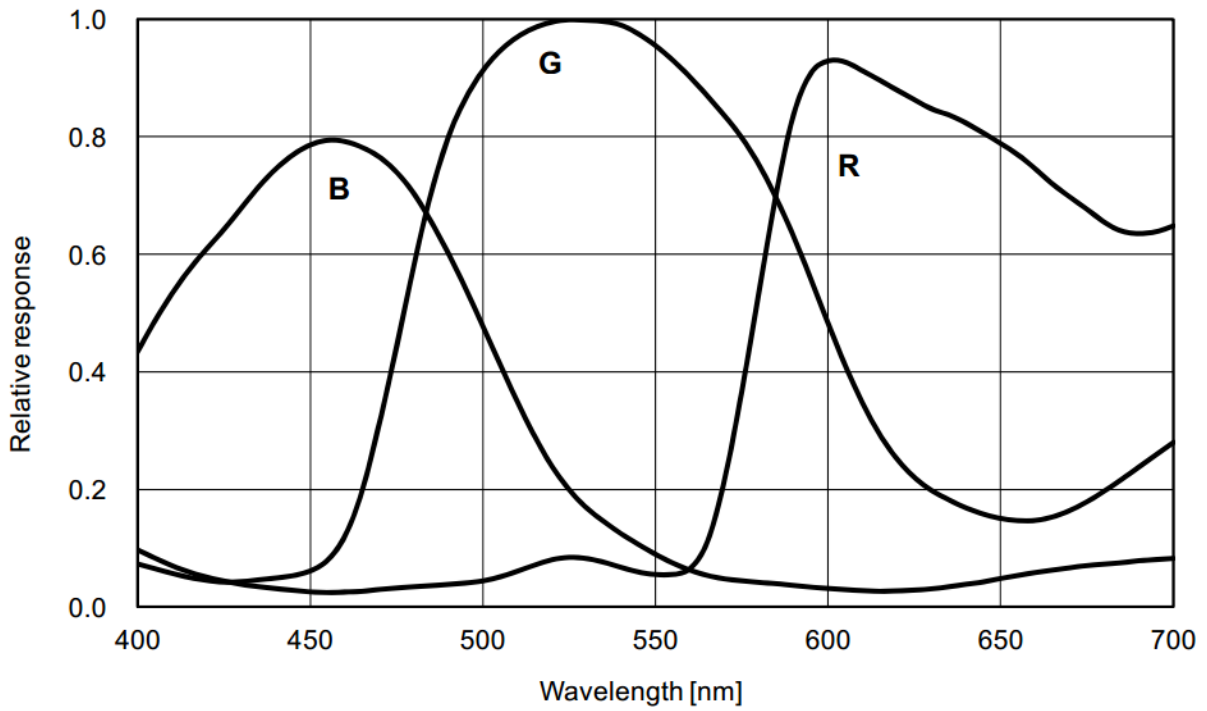

Figure 4-38 MER-2000-19U3C(-L) sensor spectral response

## 5. Dimensions

### 5.1. Camera Dimensions

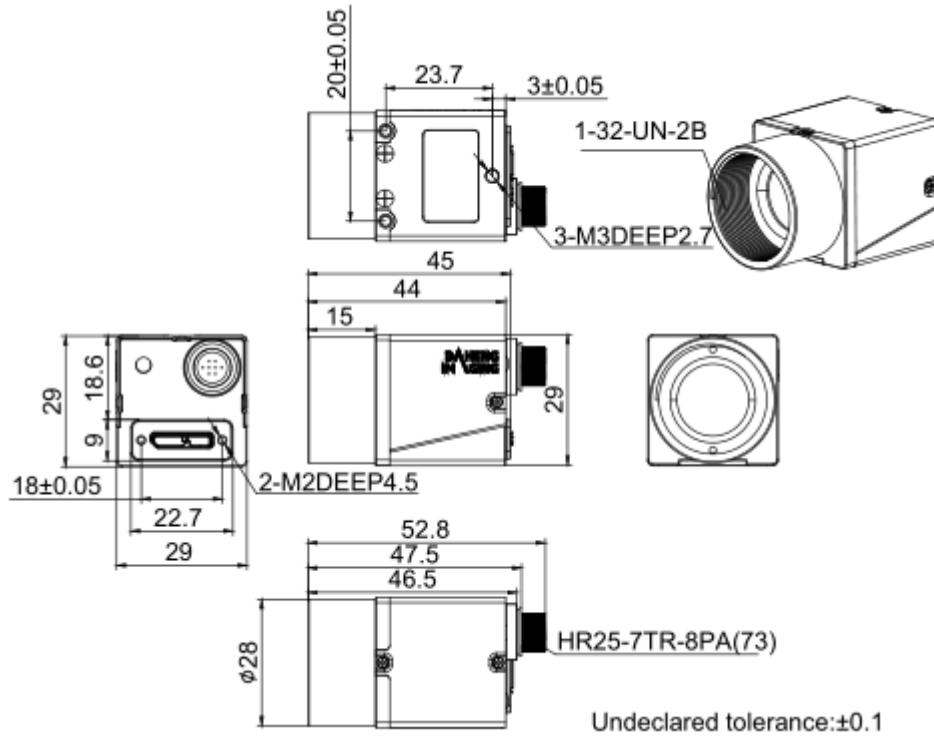

Figure 5-1 MER-U3 mechanical dimensions

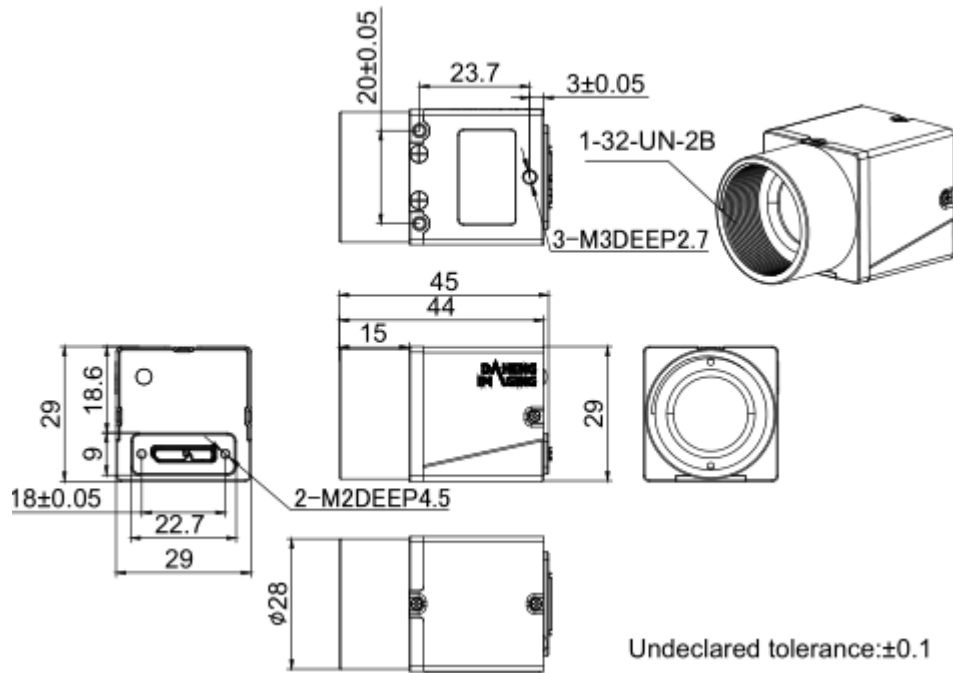

Figure 5-2 MER-U3-L mechanical dimensions

## 5.2. Optical Interface

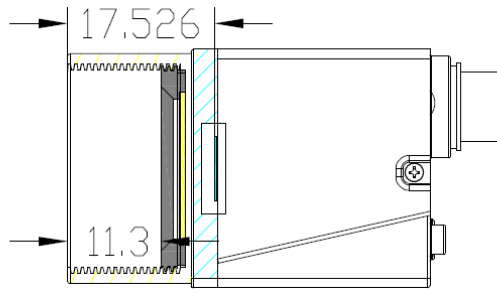

Figure 5-3 Optical interface of C-mount

MER-U3 cameras are equipped with C-mount lens adapters. The back-flange distance is 17.526 mm (in the air). The maximum allowed thread length of lens should be less than 11.3mm, as shown in Figure 5-3.

The color models are equipped with an IR filter and the cut-off frequency is 700nm. The mono models are equipped with a transparent glass. Remove IR-filter or transparent glass will defocus the image plane.

Contact our technical support when the glass needed to be removed.

## 5.3. Tripod Adapter Dimensions

When customizing the tripod adapter, you need to consider the relationship between tripod adapter, screw length and step thickness of tripod adapter.

- 1) Screw length = tripod adapter step thickness + spring washer thickness + screwing length of camera screw thread.

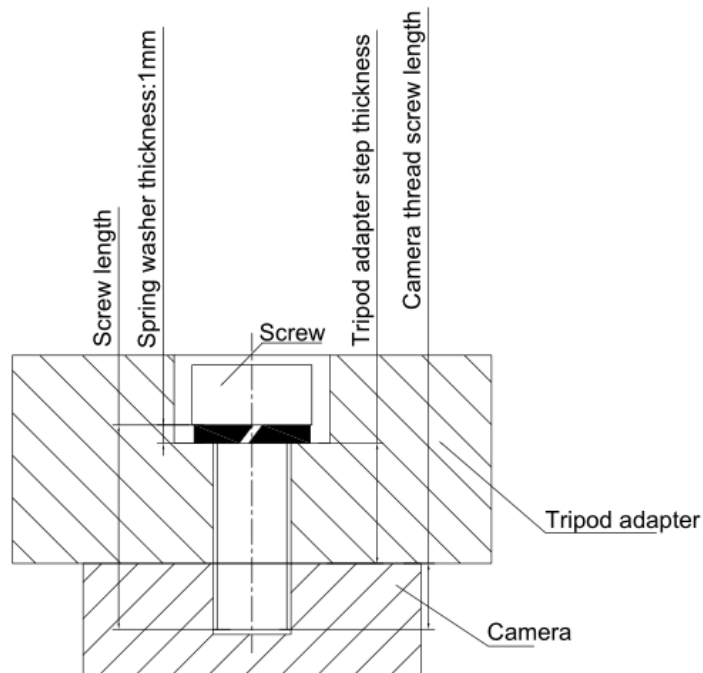

Figure 5-4 Schematic diagram of screw specification, tripod adapter step thickness and spring washer thickness

- 2) It is recommended that you select the screw specifications and the tripod adapter step thickness from the table below:

Screw specification	Tripod adapter step thickness (mm)	Spring washer thickness (mm)	Screwing length of camera screw thread (mm)
M3*6 screw	2.3	1	2.7
M3*8 screw	4.3	1	2.7
M3*10 screw	6.3	1	2.7



If the screw specification and the thickness of the tripod adapter do not conform to the above table, it may cause the camera thread hole through or thread stripping.

## 6. Filters and Lenses

### 6.1. Filters

The MERCURY color models are equipped with an IR filter. The monochrome models are equipped with a transparent glass. The following are their specifications and spectral response.

Contact our technical support when the glass needed to be removed.

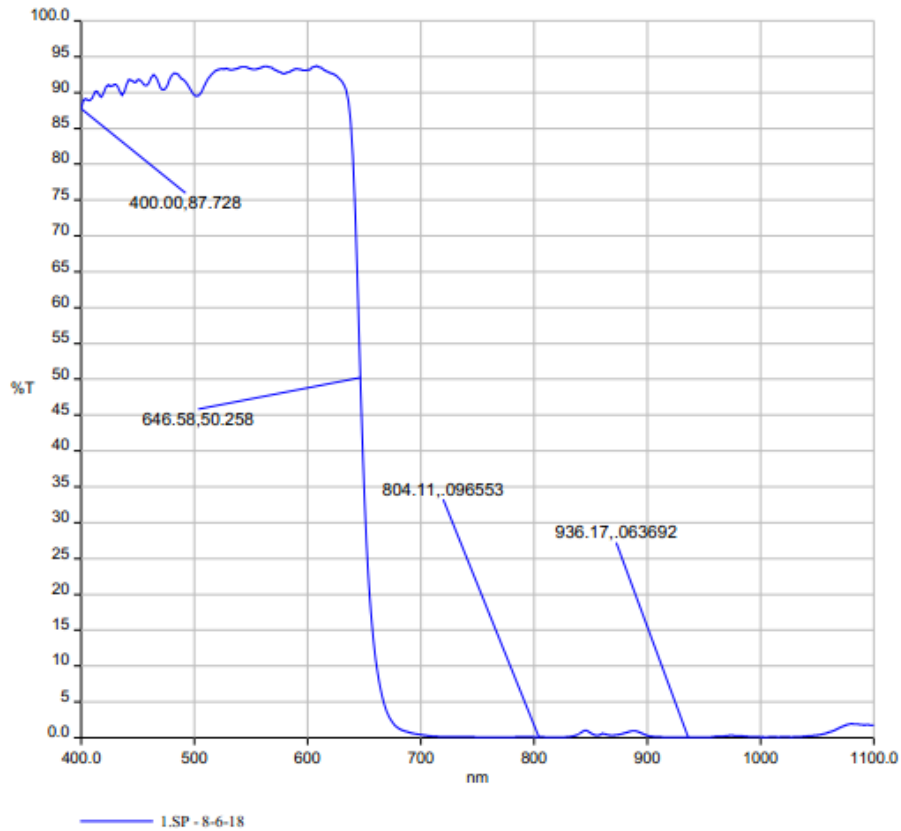

Figure 6-1 Infrared cut-off filter spectral response for MERCURY series color camera

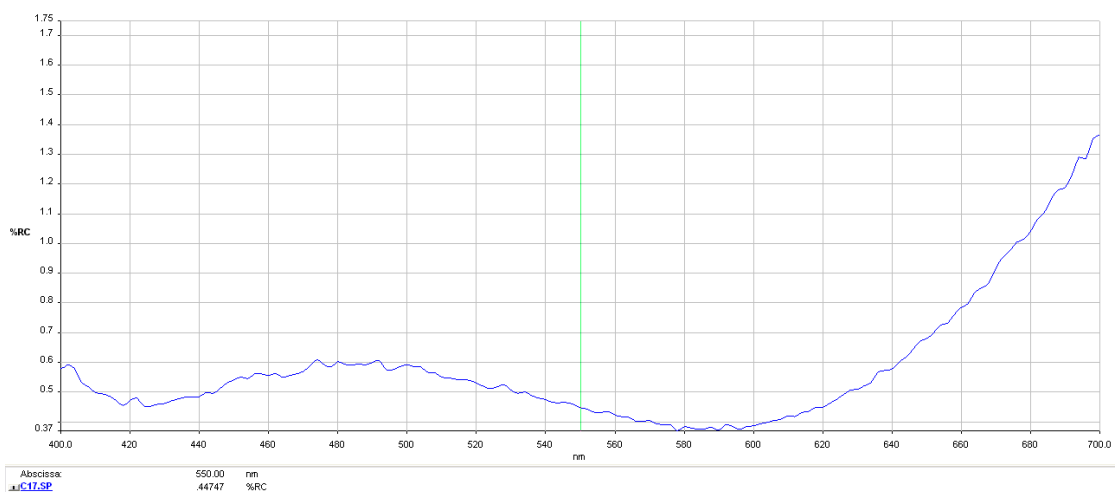

Figure 6-2 Transparent glass spectral response for MERCURY series mono camera

## 6.2. Lens Selection Reference

DAHENG IMAGING is a professional supplier for images and machine vision devices in China. In addition to industrial cameras, it also provides high-resolution, high-optical machine vision lenses for a wide range of industrial cameras on the market.

In order to meet the requirements of machine vision for high resolution and low distortion, DAHENG IMAGING released two series of lenses, including industrial lenses of 2 megapixels and 5 megapixels, with small size, light weight, high resolution and low distortion rate, etc.

When choosing a lens, there are several factors to consider:

### 1) Mount

- The lens and camera connection methods, commonly used mounts include C, CS, F, V, Leica, M42, M58, M72, M90, and so on
- The MERCURY series USB3.0 digital camera is equipped with a standard C-Mount. When selecting a lens, select the lens of the same mount as the camera

### 2) Optical size

- The maximum sensor size that the lens imaging can cover. There are mainly 1/2", 2/3", 1/1.2", 1", 1.1", 4/3", and so on
- When selecting a lens, make sure that the optical size of the lens is not smaller than the sensor size of the digital camera

### 3) Resolution

- The resolution represents the ability of the lens to record the details of the object, usually in units of line pairs that can be resolved per millimeter: line pair/mm (lp/mm). The higher the resolution of the lens, the sharper the image
- When selecting a lens, make sure that the accuracy required by the system is less than the resolution of the lens

### 4) Working distance

- The distance from the first working surface of the lens to the object being measured
- When selecting a lens, make sure that the working distance is larger than the lens parameter "minimum object distance"

### 5) Focal length

- The focal length is the distance from the center point of the lens to the clear image formed on the focal plane. The smaller the focal length, the larger the field of view of the digital camera
- For focal length calculation, we need to confirm three parameters: the field of view, the sensor size of the digital camera and the working distance. The focal length (f) of the expected lens can be calculated by the following formula



$f = \text{sensor size (horizontal or vertical)} * \text{Working distance/Field of View (corresponding to the horizontal or vertical direction of the sensor size)}$

The corresponding lens is selected by the calculated focal length.

### 6.2.1. HN-2M Series

The HN-2M series lenses are 2 megapixels for industrial, suitable for sensors with optical size of 1/2" ~ 2/3". This series of lenses has the following features:

- High optical performance with optical design supporting up to 2/3" sensor size, 6.2 $\mu\text{m}$  pixel size (up to 2 megapixels) sensor. 8 models with F values below 2.8, clear images can be obtained even in low light environment
- Excellent anti-shock and anti-vibration performance, with a unique mechanical structure, optical axis changes below 10 $\mu\text{m}$
- The housing is small and compact, the minimum outer diameter is only  $\phi 29.5\text{mm}$ , and it can be installed in various limited spaces
- Easy to install, there are 3 fixing holes on the lens barrel for fixing the iris and focusing. The best fixing hole can be selected according to the installation environment

Models:

- HN-0612-2M-C1/2X
- HN-0914-2M-C2/3X
- HN-12.514-2M-C2/3X
- HN-1614-2M-C2/3X
- HN-2514-2M-C2/3X
- HN-3516-2M-C2/3X
- HN-5023-2M-C2/3X
- HN-7528-2M-C2/3X

### 6.2.2. HN-5M Series

The HN-5M series lenses are 5 megapixels for industrial, suitable for sensors with optical size of 2/3" ~ 1.1". This series of lenses has the following features:

- 5 megapixels resolution, the definition is consistent from the center to the periphery, greatly improving the distance between iris and photography
- The housing is small and compact, the minimum outer diameter is only  $\phi 29.5\text{mm}$ , and it can be installed in various limited spaces

- Easy to install, there are 3 fixing holes on the lens barrel for fixing the iris and focusing. The best fixing hole can be selected according to the installation environment

Models:

- HN-0619-5M-C2/3X
- HN-0816-5M-C2/3X
- HN-1216-5M-C2/3X
- HN-1616-5M-C2/3X
- HN-2516-5M-C2/3X
- HN-3519-5M-C2/3X
- HN-5024-5M-C2/3X

## 7. Electrical Interface

### 7.1. LED Light

An LED light is set on the back cover of camera which indicates camera's status, as shown in Table 7-1. LED light can display 3 colors: red, yellow and green.

LED status	Camera status
Off	The camera is powered off
Solid red	The camera is not boot-loaded
Flashing red	The camera is in low power consumption mode
Solid green	The camera has been boot-loaded, but no data is being transmitted
Flashing green	Data is being transmitted
Flashing yellow	The camera's initialization failed

Table 7-1 Camera status

### 7.2. USB Port

Recommend to use the cables officially recognized by USB IF.

### 7.3. I/O Port

I/O port is implemented by Hirose 8-pin receptacle (No. HR25-7TR-8PA (73)), and the corresponding plug is HR25-7TP-8S.

Diagram	Pin	Definition	Core Color	Description
	1	Line0+	Green	Opto-isolated input +
	2	GND	Blue	GPIO GND
	3	Line0-	Grey	Opto-isolated input -
	4	NC	Purple	NC
	5	Line2	Orange	GPIO input/output
	6	Line3	Pink	GPIO input/output

	7	Line1-	White Green	Opto-isolated output -
	8	Line1+	White Blue	Opto-isolated output +

Table 7-2 I/O port definition (back sight of the camera)



The polarity of GPIO pins cannot be reversed, otherwise, camera or other peripherals could burn out.

### 7.3.1. Line0 (Opto-isolated Input) Circuit

Hardware schematics of opto-isolated input circuit is shown as Figure 7-1.

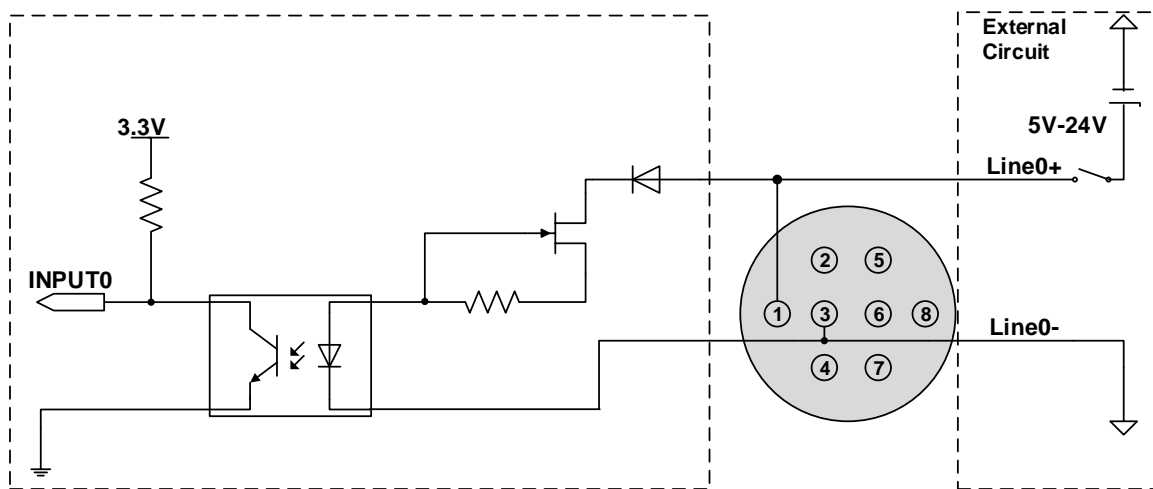

Figure 7-1 Opto-isolated input circuit

- Logic 0 input voltage: 0V~+2.5V (Line0+ voltage)
- Logic 1 input voltage: +5V~+24V (Line0+ voltage)
- Minimum input current: 7mA
- The status is unstable when input voltage is between 2.5V and 5V, which should be avoided
- When peak voltage of input signal over 9V, a current limiting resistor is recommended to protect the input Line0+. The recommended resistance is shown in Table 7-3

Line0+ input voltage	Circuit-limiting resistance Rlimit
9V	680Ω
12V	1kΩ
24V	2kΩ

Table 7-3 Circuit-limiting resistor value for Line0+

- Rising edge delay: <math><50\mu\text{s}</math> ( $0^{\circ}\text{C}\sim 45^{\circ}\text{C}$ ), parameter description as shown in Figure 7-2
- Falling edge delay: <math><50\mu\text{s}</math> ( $0^{\circ}\text{C}\sim 45^{\circ}\text{C}$ ), parameter description as shown in Figure 7-2
- Different environment temperature and input voltage have influence on delay time of opto-isolated input circuit. Delay times in typical application environment (temperature is  $25^{\circ}\text{C}$ ) is as shown in Table 7-4

Parameter	Test condition	Value (us)		
			~	
Rising edge delay	VIN=5V	3.02	~	6.96
	VIN=12V	2.46	~	5.14
Falling edge delay	VIN=5V	6.12	~	17.71
	VIN=12V	8.93	~	19.73

Table 7-4 Delay time of opto-isolated input circuit in typical application environment

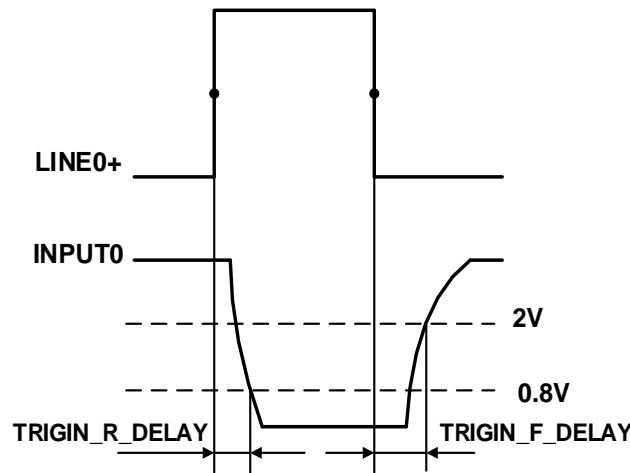

Figure 7-2 Parameter of opto-isolated input circuit

- Rising time delay (TRIGIN\_R\_DELAY): the time required for the response to the decrease to 0.8V of INPUT0 from 50% rising of LINE0+
- Falling time delay (TRIGIN\_F\_DELAY): the time required for the response to the rise to 2V of INPUT0 from 50% falling of LINE0+

### 7.3.2. Line1 (Opto-isolated Output) Circuit

Hardware schematics of opto-isolated output circuit is shown as Figure 7-3.

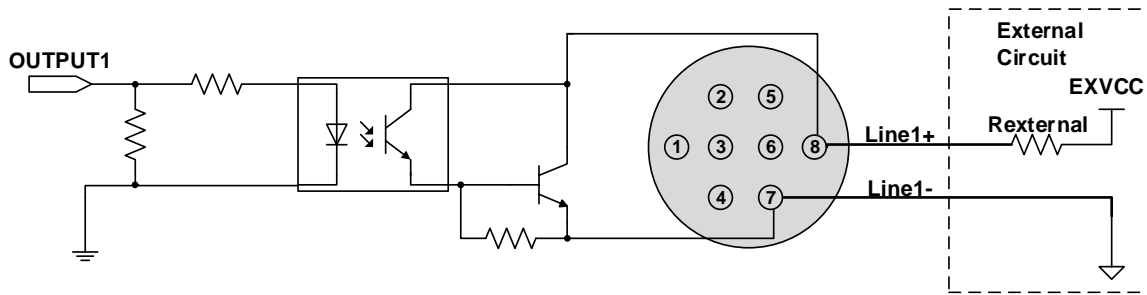

Figure 7-3 Opto-isolated output circuit

- Range of external voltage (EXVCC) is 5~24V
- Maximum output current of Line1 is 25mA
- Output voltage and output current of opto-isolated output circuit in typical application environment (temperature is 25°C) is as shown in Table 7-5

External voltage EXVCC	External resistance Rexternal	Output voltage (V)	Output current (mA)
5V	1kΩ	0.90	4.16
12V	1kΩ	0.97	11.11
24V	1kΩ	1.04	23.08

Table 7-5 Output voltage and output current of opto-isolated output circuit in typical application environment

- Rising time delay = tr+td: <50μs (0°C~45°C) (parameter description is shown in Figure 7-4)
- Falling time delay = ts+tf: <50μs (0°C~45°C) (parameter description is shown in Figure 7-4)
- Delay time in typical application conditions (environment temperature is 25°C) are shown in Table 7-6

Parameter	Test Condition	Value (us)		
Storage time (ts)	External power is 5V, pull-up resistor is 1kΩ	6.16	~	13.26
Delay time (td)		1.90	~	3.16
Rising time (tr)		2.77	~	10.60
Falling time (tf)		7.60	~	11.12
Rising time delay = tr+td		4.70	~	13.76
Falling time delay = tf+ts		14.41	~	24.38

Table 7-6 Delay time of opto-isolated output circuit in typical application environment

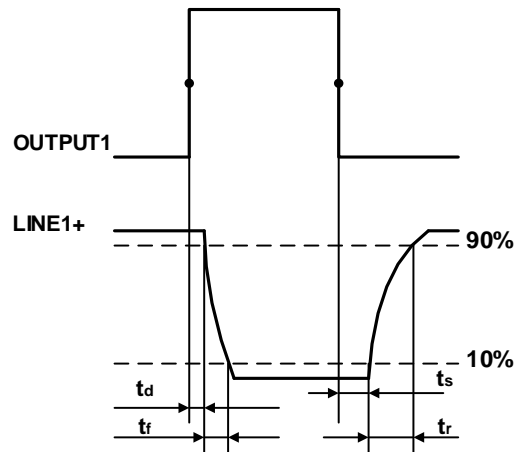

Figure 7-4 Parameter of opto-isolated output circuit

- Delay time ( $t_d$ ): the time required from 50% rising of OUTPUT1 to the decrease to 90% of the maximum value of LINE1+
- Falling time ( $t_f$ ): the time taken for the amplitude of LINE1+ to decrease from 90% to 10% of the maximum value
- Storage time ( $t_s$ ): the time required from 50% falling of OUTPUT1 to the rise to 10% of the maximum value of LINE1+
- Rising time ( $t_r$ ): the time for the response of LINE1+ to rise from 10% to 90% of its final value

### 7.3.3. Line 2/Line3 (Bidirectional) Circuit

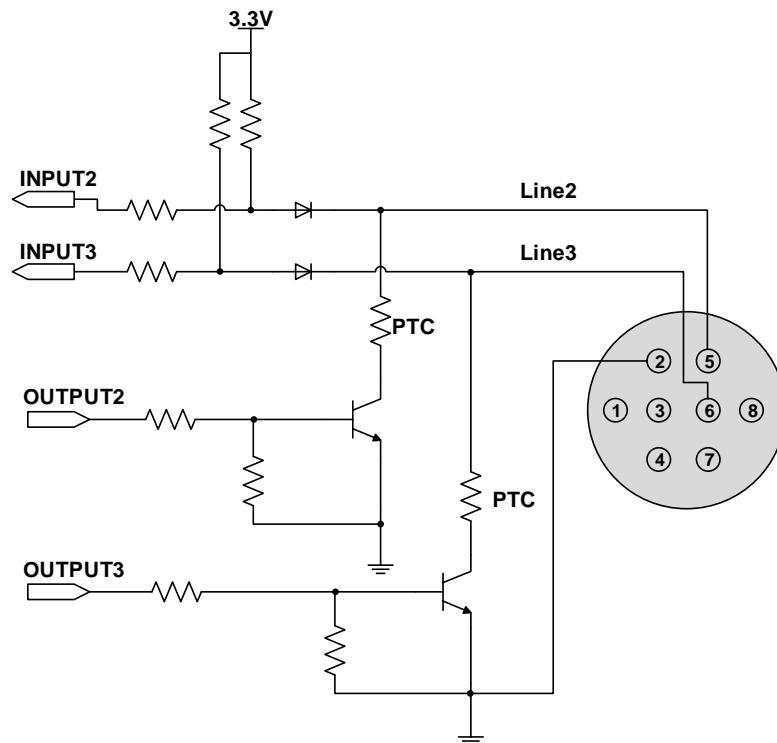

Figure 7-5 Line2/Line3 (bidirectional) circuit

7.3.3.1. Line2/3 is Configured as Input

- When Line2/3 is configured as input, the internal equivalent circuit of camera is shown in Figure 7-6, taking Line2 as an example

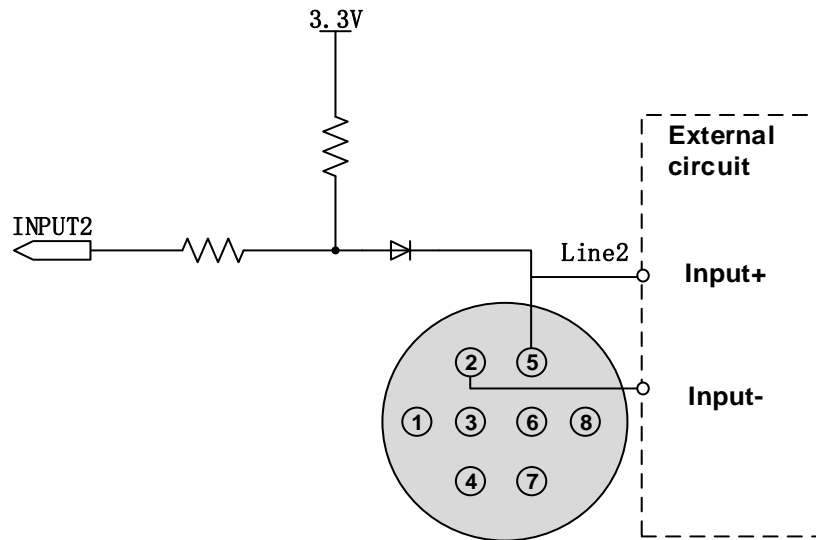

Figure 7-6 Internal equivalent circuit of camera when Line2 is configured as input



To avoid the damage of GPIO pins, please connect GND pin before supplying power to Line2/3.

- Logic 0 input voltage: 0V~+0.6V(Line2/3 voltage)
- Logic 1 input voltage: +1.9V~+24V(Line2/3 voltage)
- The status is unstable when input voltage is between 0.6V and 1.9V, which should be avoided.

When input of Line2/3 is high, input current is lower than 100uA. When input of Line2/3 is low, input current is lower than -1mA.

When Line2/3 is configured as input. The connection method between them and NPN and PNP photoelectric sensors is shown in Figure 7-7 and Figure 7-8. The relationship between the pull-up resistor value and the external input voltage is shown in Table 7-3.



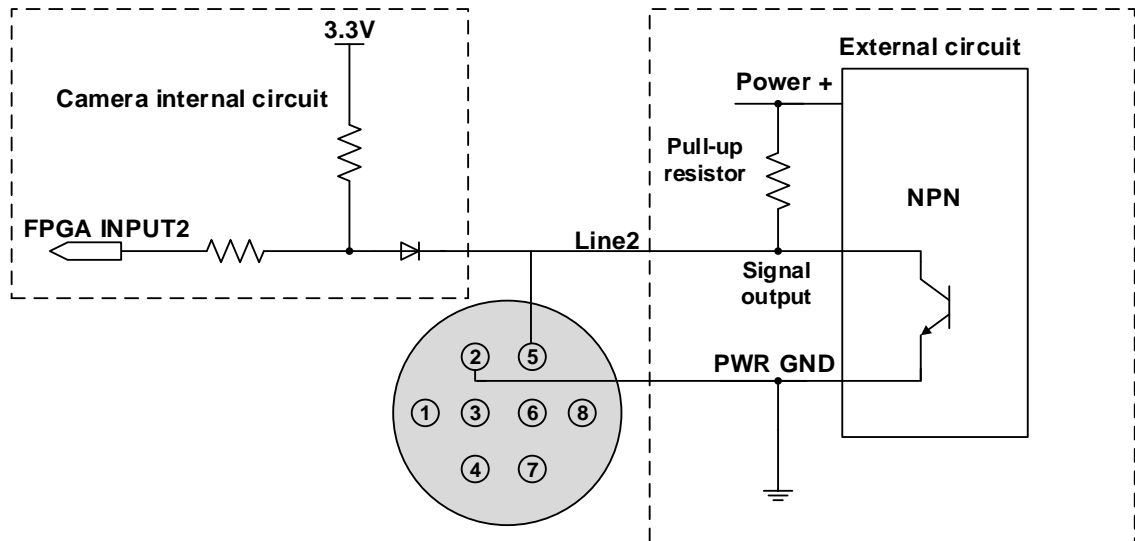

Figure 7-7 NPN photoelectric sensor connected to Line2 input circuit

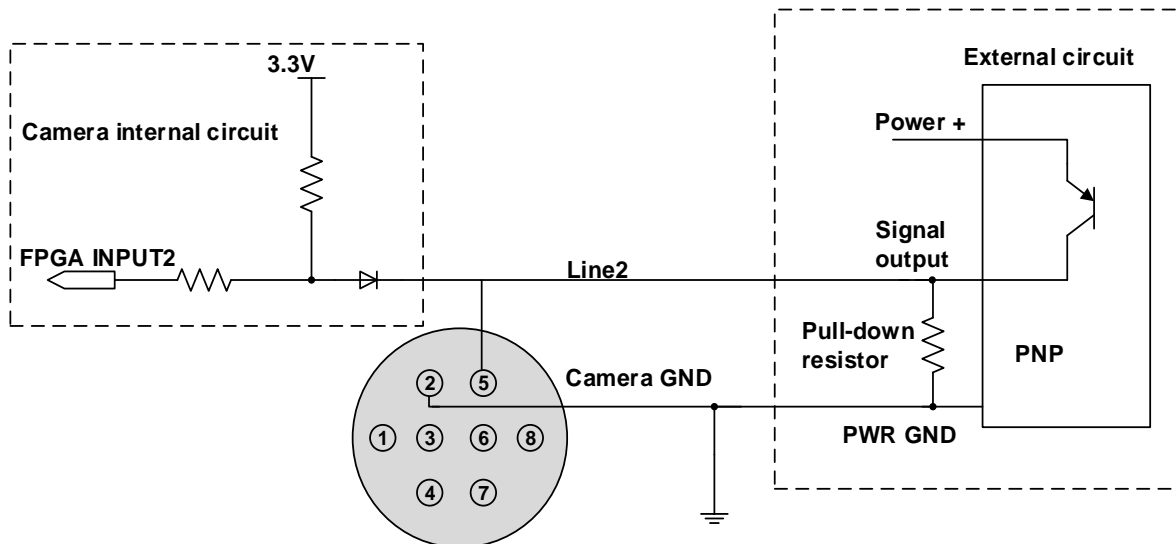

Figure 7-8 PNP photoelectric sensor connected to Line2 input circuit

- When Lline2/3 is configured as input, pull-down resistor over 1K should not be used, otherwise the input voltage of Line2/3 will be over 0.6V and logic 0 cannot be recognized stably
- Input rising time delay:  $<2\mu\text{s}$  ( $0^{\circ}\text{C}\sim 45^{\circ}\text{C}$ ), parameter description as shown in Figure 7-2
- Input falling time delay:  $<2\mu\text{s}$  ( $0^{\circ}\text{C}\sim 45^{\circ}\text{C}$ ), parameter description as shown in Figure 7-2

### 7.3.3.2. Line2/3 is Configured as Output

- Range of external voltage (EXVCC) is 5~24V
- Maximum output current of Line2/3 is 25mA, output impedance is  $40\Omega$
- Output voltage and output current in typical application conditions (temperature is  $25^{\circ}\text{C}$ ) are shown in Table 7-7

External voltage EXVCC	External resistance Rexternal	Line2/3 voltage (V)	Output current (mA)
5V	1kΩ	0.19	4.8
12V		0.46	11.6
24V		0.92	23.1

Table 7-7 Voltage and output current of Line2/3 in typical conditions

- Rising time delay = tr+td: <math><20\mu\text{s}</math> (0°C~45°C) (parameter description as shown in Figure 7-4)
- Falling time delay = ts+tf: <math><20\mu\text{s}</math> (0°C~45°C) (parameter description as shown in Figure 7-4)
- Delay parameters are affected greatly by external voltage and external pull-up resistor, but little by temperature. Output delay time in typical application conditions (temperature is 25°C) are shown in Table 7-8

Parameter	Test Conditions	Value (us)		
Storage time (ts)	External power is 5V, pull-up resistor is 1kΩ	0.17	~	0.18
Delay time (td)		0.08	~	0.09
Rising time (tr)		0.11	~	0.16
Falling time (tf)		1.82	~	1.94
Rising time delay = tr+td		0.19	~	0.26
Falling time delay = tf+ts		1.97	~	2.09

Table 7-8 Delay time when GPIO is configured as output in typical conditions

- When Line2/3 is configured as output, the internal equivalent circuit of camera is shown in Figure 7-9, taking Line2 as an example

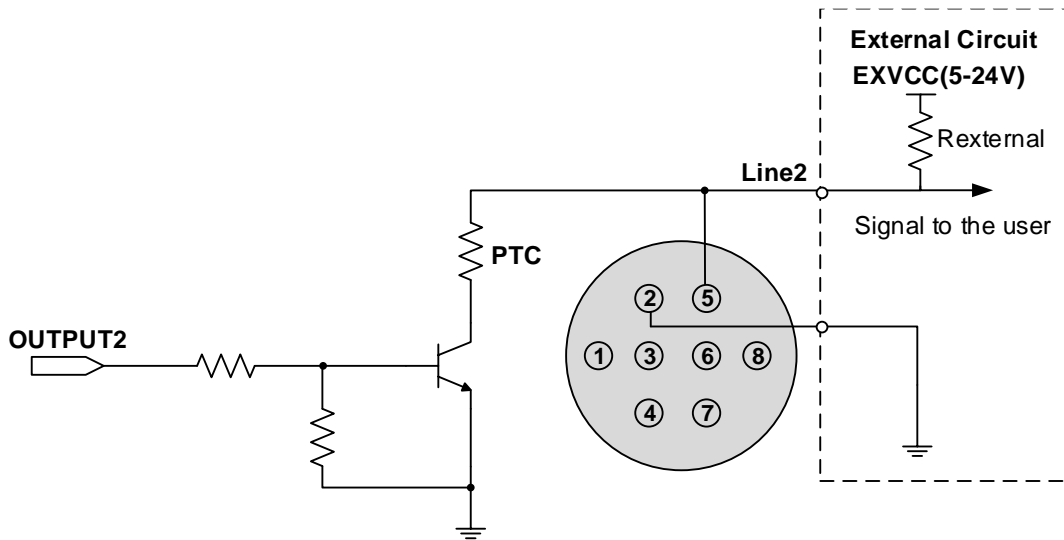

Figure 7-9 Internal equivalent circuit of camera when Line2 is configured as output

## 8. Features

### 8.1. I/O Control

#### 8.1.1. Input Mode Operation

##### 1) Configuring Line as input

The MER-U3 series camera has three input signals: Line0, Line2, and Line3. In which the Line0 is uni-directional opto-isolated input, Line2 and Line3 are bi-directional lines which can be configured as input or output.

The camera's default input is Line0 when the camera is powered on. Line2 and Line3 are input by default, which can be configured to be input or output by LineMode.

##### 2) Input Debouncer

In order to suppress the interference signals from external trigger, the MER-U3 series camera has the external trigger filtering feature, including rising edge filtering and falling edge filtering. The user can set the trigger filter feature by setting the "TriggerFilterRaisingEdge" and the "TriggerFilterFallingEdge". The range of the trigger filter feature is [0, 5000]  $\mu$ s, step: 1 $\mu$ s.

Example 1: Setting the rising edge filter width to 1ms, the pulse width less than 1ms in the rising edge will be filtered out, as shown in Figure 8-1:

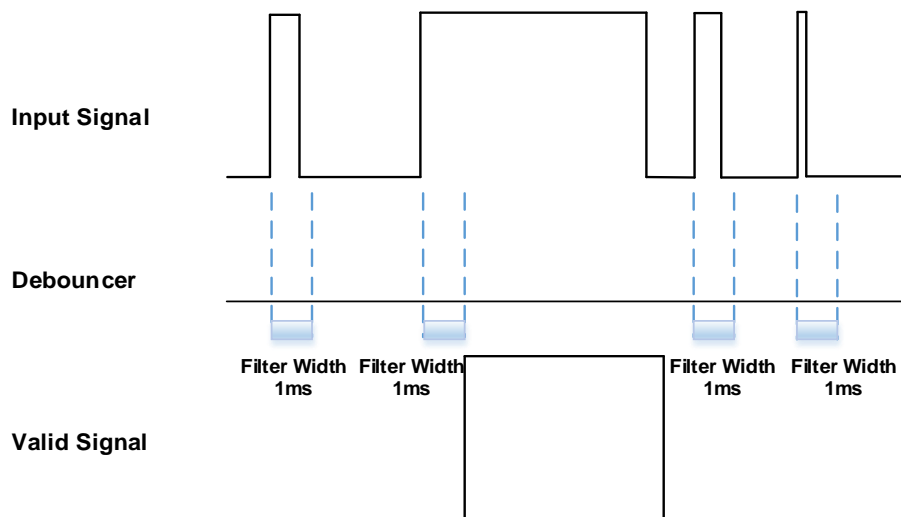

Figure 8-1 Input debouncer schematic diagram

##### 3) Trigger Delay

The MER-U3 series camera has trigger delay feature. The user can set the trigger delay feature by setting "TriggerDelay". The range of the trigger delay feature is [0, 3000000]  $\mu$ s, step: 1 $\mu$ s.

Example 1: Setting the trigger delay value to 1000ms, and the trigger signal will be valid after 1000ms delay, as shown in Figure 8-2.

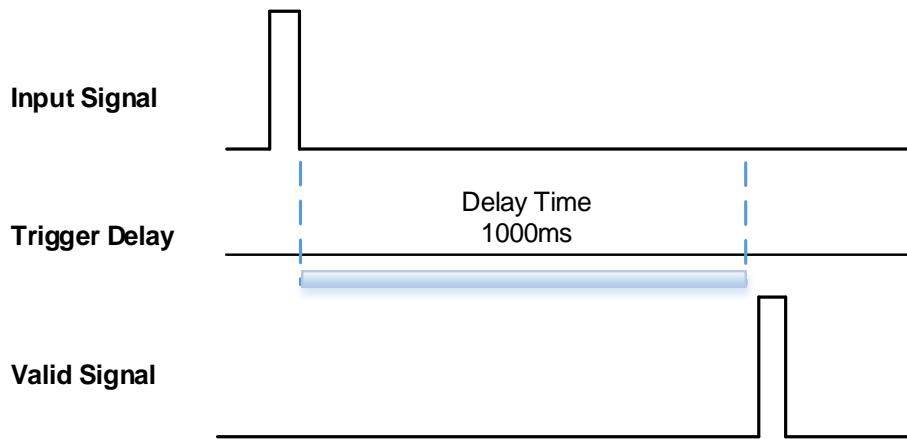

Figure 8-2 Trigger delay schematic diagram

#### 4) Input Inverter

The signal level of input lines is configurable for the MER-U3 series camera. The user can select whether the input level is reverse or not by setting "LineInverter".

For the MER-U3 series camera, the default input line level is false when the camera is powered on, indicating that the input line level is not reversed. If it is set as true, indicating that the input line level is reversed. As shown in the Figure 8-3:

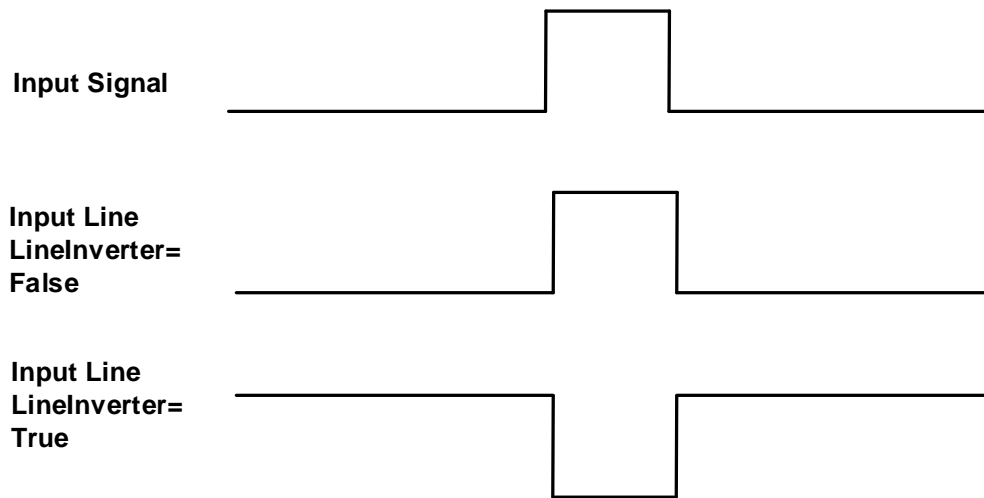

Figure 8-3 Setting input line to reverse

### 8.1.2. Output Mode Operation

#### 1) Configuring Line as output

The MER-U3 series camera has three output signals: Line1, Line2, and Line3. In which the Line1 is a uni-directional opto-isolated output I/O, Line2 and Line3 are bi-direction configurable I/Os.

The camera's default output is Line1 when the camera is powered on. Line2 and Line3 can be configured to be output by changing the "LineMode" of this line.

Each output source of the three output lines is configurable, and the output source includes: Strobe, UserOutput0, UserOutput1, UserOutput2.

The default output source of the camera is UserOutput0 when the camera is powered on.

## 2) Setting the user-defined status for the output lines

The MER-U3 series camera can select the user-defined output by setting "LineSource", by setting "UserOutputValue" to configure the output signal.

By setting "UserOutputSelector" to select UserOutput0, UserOutput1 or UserOutput2.

By setting "UserOutputValue" to set the user-defined output value, and the default value is false when the camera is powered on.

## 3) Output Inverter

In order to facilitate the camera IO configuration and connection, the MER-U3 series camera can configure output signal level. The user can select whether the output level is reverse or not by setting "LineInverter".

The default output signal level is false when the camera is powered on, indicating that the output line level is not reversed. If it is set as true, indicating that the output line level is reversed. As shown in the Figure 8-4.

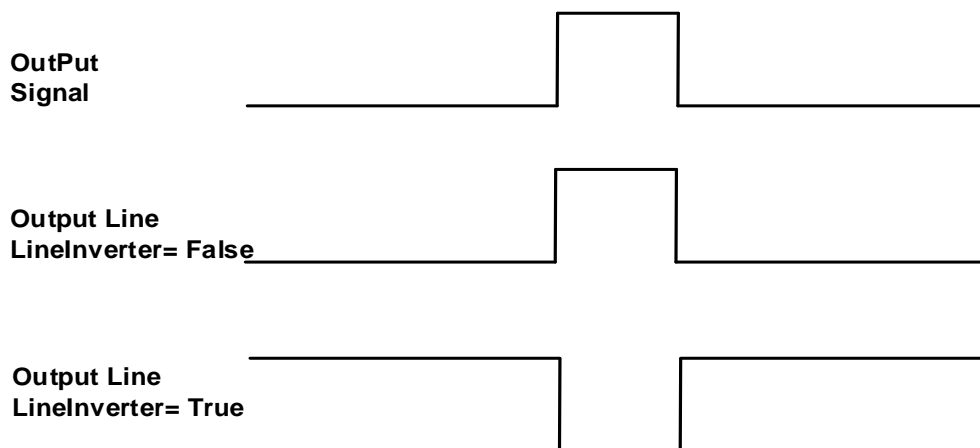

Figure 8-4 Set output line reversion

### 8.1.3. Read the LineStatus

#### 1) Read the level of single line

The MER-U3 series camera can get the line's signal status. When the device is powered on, the default status of Line0 and Line1 is false, and the default status of Line2 and Line3 is true.

#### 2) Read all the lines level

The MER-U3 series camera can get the current status of all lines. On the one hand, the signal status is the status of the external IO after the reversal of the polarity. On the other hand, signal status level can reflect the external IO level.

All the lines level status bit of the MER-U3 series camera are shown in Table 8-1. The default polarity does not reverse, and the default value is 0xC.

Line3	Line2	Line1	Line0
1	1	0	0

Table 8-1 Camera line status bit

## 8.2. Image Acquisition Control

### 8.2.1. Acquisition Start and Stop

#### 8.2.1.1. Acquisition Start

It can send **AcquisitionStart** command immediately after opening the camera. The acquisition process in continuous mode is illustrated in Figure 8-5, and the acquisition process in trigger mode is illustrated in Figure 8-6.

- **Continuous Acquisition**

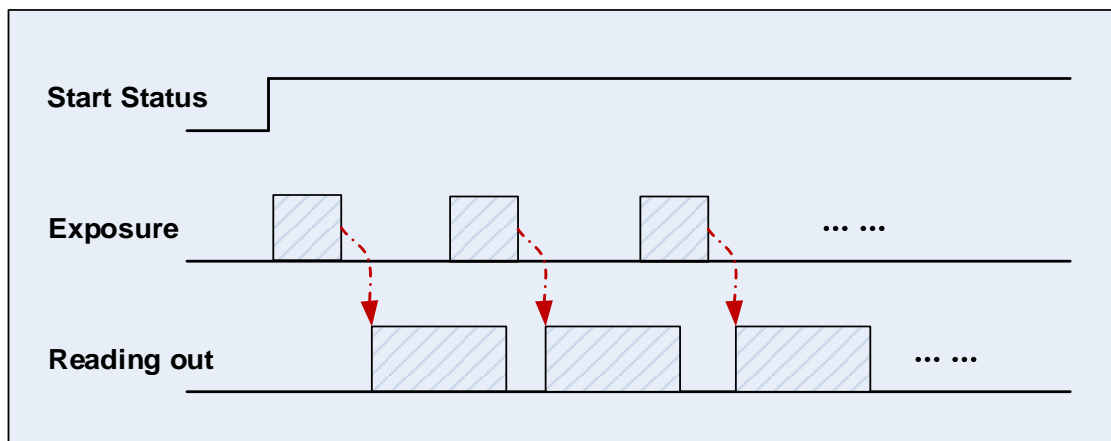

Figure 8-5 Continuous acquisition process

In continuous mode, a camera starts to expose and read out after receiving the **AcquisitionStart** command. The frame rate is determined by the exposure time, ROI and some other parameters.

- **Trigger Acquisition**

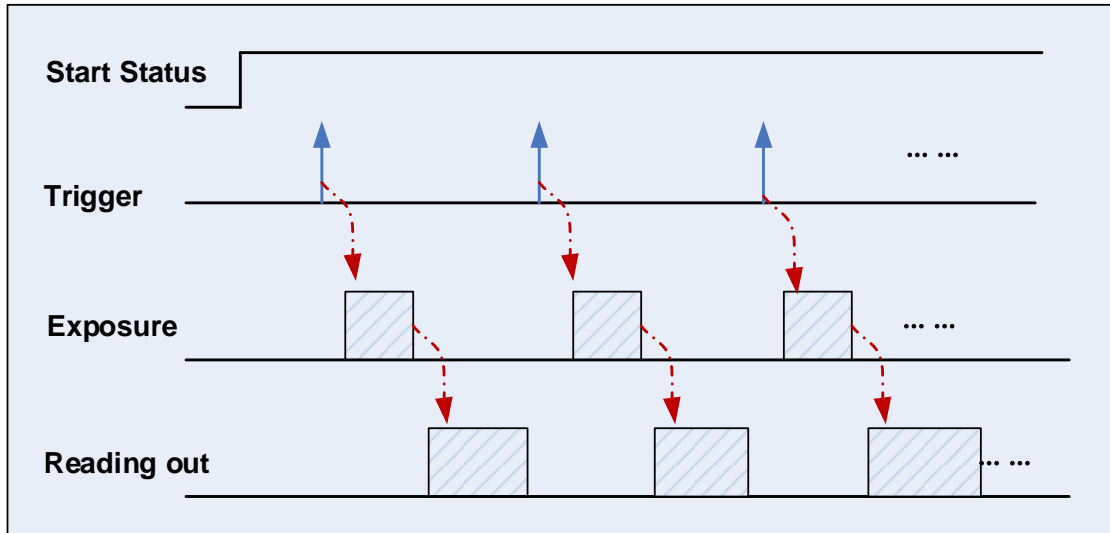

Figure 8-6 Trigger acquisition process

In trigger mode, sending **AcquisitionStart** command is not enough, a trigger signal is also needed. Each time a frame trigger is applied (including software trigger and external trigger), the camera will acquire and transmit a frame of image.

#### 8.2.1.2. Acquisition Stop

It can send **AcquisitionStop** command to camera at any time. The acquisition stop process is irrelevant to acquisition mode. But different stop time will result in different process, as shown in Figure 8-7 and Figure 8-8.

- **Acquisition stop during reading out**

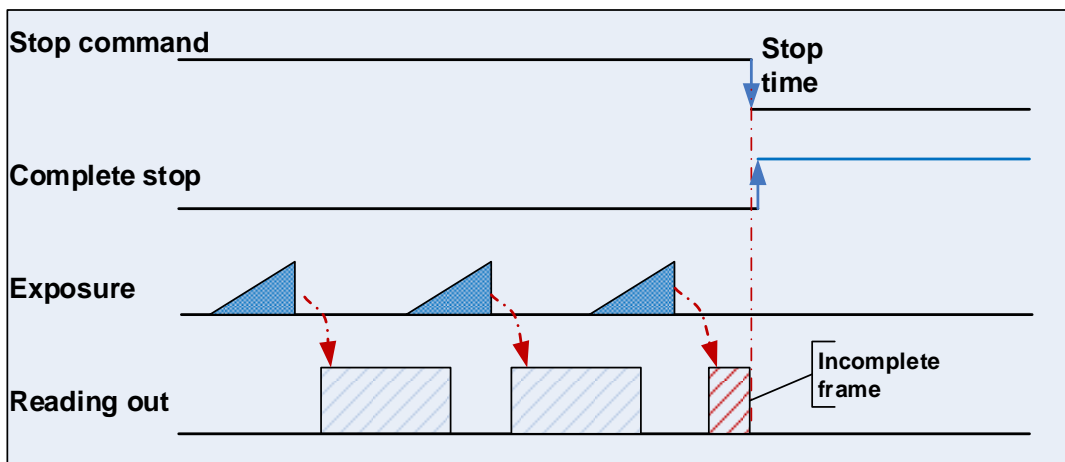

Figure 8-7 Acquisition stop during reading out

As shown in Figure 8-7, when the camera receives an **AcquisitionStop** command during reading out, it stops transferring frame data immediately. The currently transferred frame data is regarded as incomplete frame and will be discarded.

- **Acquisition stop during blanking**



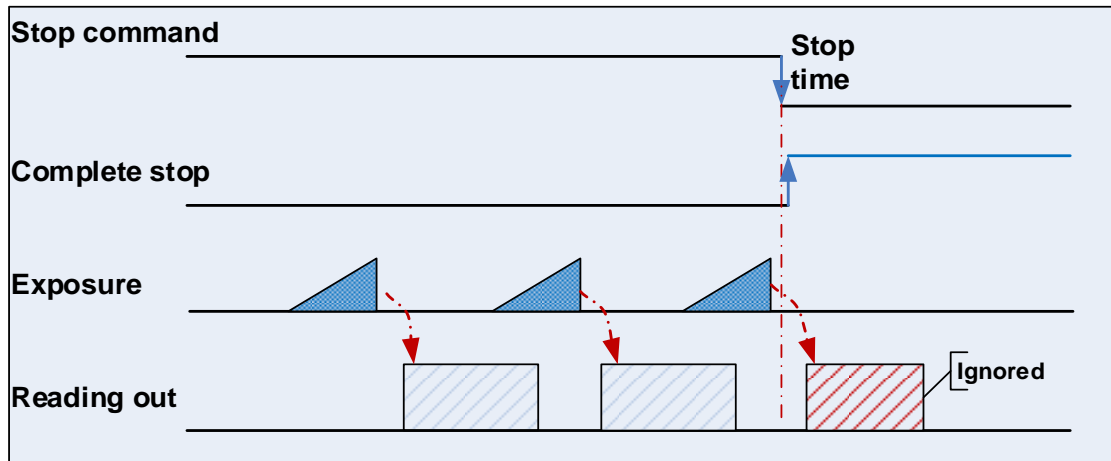

Figure 8-8 Acquisition stop during blanking

After the camera transferred a whole frame, the camera goes into wait state. When user sends an **AcquisitionStop** command in wait state, the camera will return to stop acquisition state. The camera will not send any frames even if it is just going to start the next exposing.

### 8.2.2. RegionSendMode

MER-134-93U3M/C(-L) camera supports MultiROISendMode, any other cameras only support SingleROISendMode. MultiROISendMode means the camera sends several images after one exposure as shown in Figure 8-9, while SingleROISendMode means the camera sends only one image after one exposure as shown in Figure 8-10.

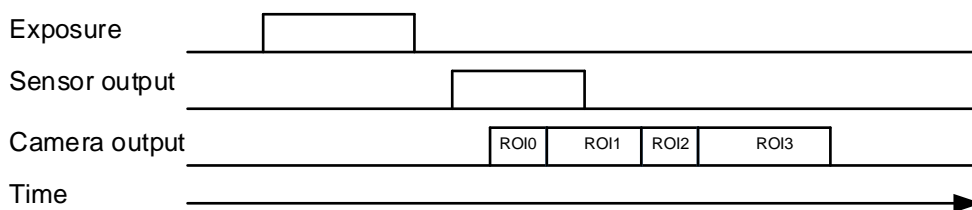

Figure 8-9 MultiROISendMode

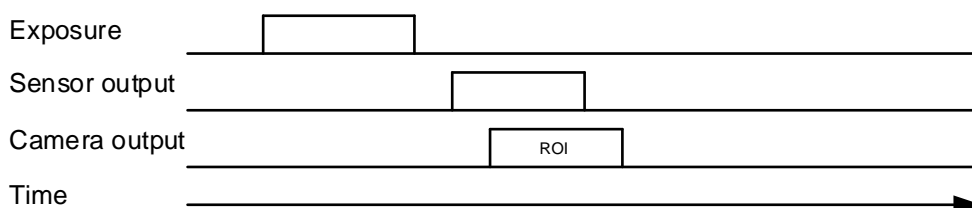

Figure 8-10 SingleROISendMode

In the SingleROISendMode, the image sensor of the camera outputs only the image of the corresponding region of the ROI.

In the MultiROISendMode, the camera will calculate the multi-ROI parameters that are set by the user and the equivalent ROI parameters, then the image sensor will output the image of the corresponding region of the equivalent ROI parameters.

- The calculation method of the equivalent ROI parameters

Equivalent Width: The equivalent width is the minimum width that can include all ROIs which are projected on horizontal axis.

Equivalent Height: The equivalent height is the sum of all ROI projections on the vertical axis.

As shown in Figure 8-11, the equivalent width is width, and the equivalent height is the sum of height1, height2, and height3.

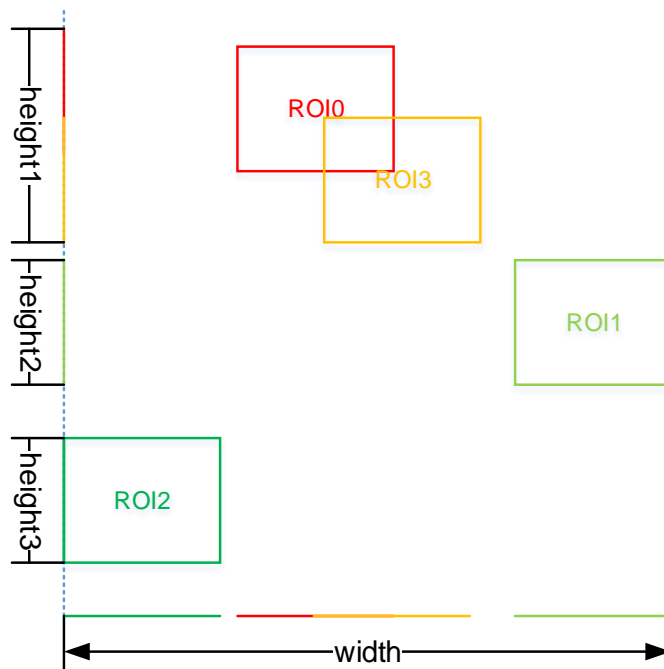

Figure 8-11 Equivalent width and equivalent height

Multi-ROI camera can be switched between MultiROISendMode and SingleROISendMode, it can be switched only in stop acquisition mode.

#### 8.2.2.1. Single ROI mode and Configuration

In the demonstration program (GalaxyView.exe), if the user wants to use the single ROI mode, sets like this: in the “image format control” option and” ROI output mode” menu, select “SingleROISendMode”. The Multi-ROI camera works in single ROI mode by default when the camera is powered on.

In single ROI mode, the user can only set Region0. If the user wants to change the parameters of Region0, in the “image format” option and pull-down menu of “Region selection”, select the “Region0”, then change the image width, image height, horizontal offset and vertical offset.

#### 8.2.2.2. Multi-ROI mode and Configuration

In the demonstration program (GalaxyView.exe), if the user wants to use the multi-ROI mode, sets like this: in the “image format control” option and” ROI output model” menu, select “MultiROISendMode”.

In multi-ROI mode, the MER-134-94U3x camera supports up to 4 ROIs, Region0, Region1, Region2 and Region3, which means one exposure can output 4 frame images. The height, width, horizontal offset and vertical offset of the ROI can be modified.

- Region0 setting

The Region0 cannot be closed. If the user wants to change the parameters of the Region0, in the “image format” option and pull-down menu of “Region selection”, select the “Region0”, then change the image width, image height, horizontal offset and vertical offset.

- Region1 setting

The Region1 can be set as open or close. If the user wants to close the Region1, just select “Region1” in the pull-down menu of “Region selection” in the “image format” option, and select “Off” in the pull-down menu of “Region Switch”. When the Region1 is closed, setting the image width, image height, horizontal offset and vertical offset will not have any effects.

If the user wants to open Region1, just select “Region1” in the “image format” option, select “Region1” in the pull-down menu of “Region selection”, and select “On” in the pull-down menu of “regional switches”. When the Region1 is opened, setting the image height, image width, and horizontal offset and vertical offset will enable the camera to output the image of the corresponding region.

- Region2 setting

The Region2 can be set as open or close. If the user wants to close the Region2, just select “Region1” in the pull-down menu of “Region selection” in the “image format” option, and select “Off” in the pull-down menu of “Region Switch”. When the Region2 is closed, setting the image width, image height, horizontal offset and vertical offset will not have any effects.

If the user wants to open Region2, just select “Region2” in the “image format” option, select “Region2” in the pull-down menu of “Region selection”, and select “On” in the pull-down menu of “regional switches”. When the Region2 is opened, setting the image height, image width, horizontal offset and vertical offset will enable the camera to output the image of the corresponding region.

- Region3 setting

The Region3 can be set as open or close. If the user wants to close the Region3, just select “Region3” in the pull-down menu of “Region selection” in the “image format” option, and select “Off” in the pull-down menu of “Region Switch”. When the Region3 is closed, setting the image width, image height, horizontal offset and vertical offset will not have any effects.

If the user wants to open Region3, just select “Region3” in the “image format” option, select “Region3” in the pull-down menu of “Region selection”, and select “On” in the pull-down menu of “regional switches”. When the Region3 is opened, setting the image height, image width, and horizontal offset and vertical offset will enable the camera to output the image of the corresponding region.

### 8.2.3. Switching Acquisition Mode

Trigger mode supports two options: **ON** and **OFF**. When trigger mode is set **OFF**, the camera works in continuous mode; when trigger mode is set **ON**, the camera works in trigger mode. It can be switched between **ON** and **OFF** any time after the camera is opened.

As shown below, switching the acquisition mode at different positions will have different results.

- **Switch acquisition mode during frame reading out**

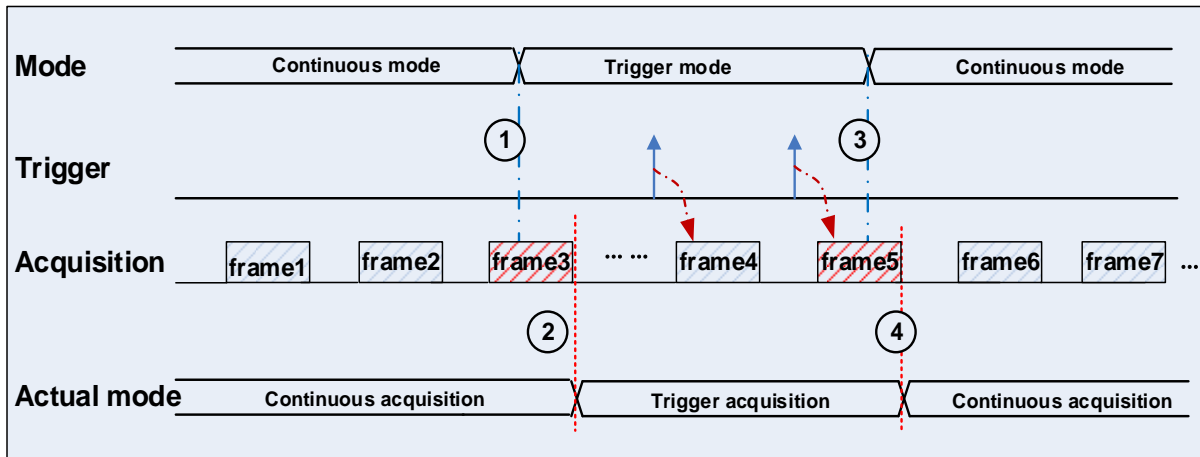

Figure 8-12 Switch acquisition mode during reading out

As shown in Figure 8-12, the camera starts with trigger mode **OFF** after receiving acquisition start command.

At point 1, the camera gets a command of setting trigger mode **ON** while transferring the 3<sup>rd</sup> frame in trigger mode OFF. The trigger mode is not active until the 3<sup>rd</sup> frame is finished, that is point 2, and then the trigger signal is also allowed. At point 3, the camera gets a command of switching back to **OFF**. It is also not active until the 5<sup>th</sup> frame is finished, it should wait a complete reading out. The camera actually switches from trigger mode to continuous mode at point 4, and then the camera works in continuous mode.

- **Switch acquisition mode during blanking (or exposing)**

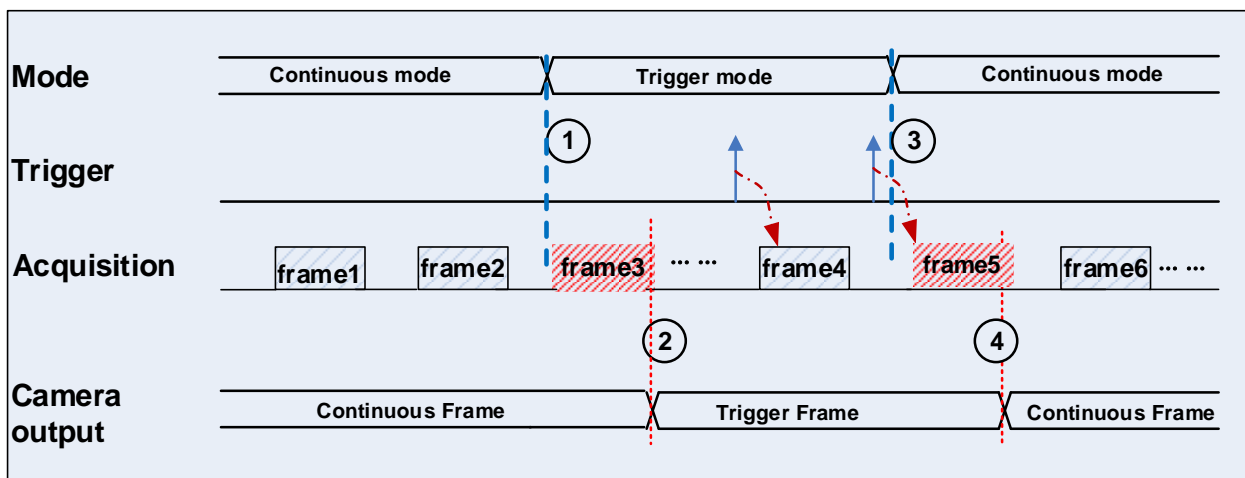

Figure 8-13 Switch acquisition mode in waiting time

As shown in Figure 8-13, the camera with trigger mode **OFF** begins after receiving an **AcquisitionStart** command.

At point 1, the camera gets a command of setting trigger mode **ON** while it is in wait state. The trigger mode is not active until the 3<sup>rd</sup> frame is finished (including exposure and reading out), i.e., point 2. Please note that the 3<sup>th</sup> frame does not belong to trigger mode. All trigger frames need trigger signals or software trigger commands. At point 3, the camera gets a command of switching back to continuous mode. It is also not active until the 5<sup>th</sup> frame is finished, it should wait a complete frame. The camera switches from trigger mode to continuous mode at point 4 actually, and then the camera works in continuous mode.



When switching from continuous mode to trigger mode, the trigger signal is blocked in the first 100ms after switching mode. Please make sure to send the trigger signal after 100ms. This is only required for the MER-1520-13U3C(-L), MER-1070-14U3M/C(-L) and MER-1810-21U3C(-L), not for all other models.

#### 8.2.4. Continuous Mode and Configuration

- Continuous mode configuration

The default value of **TriggerMode** is **OFF** in default user set. If the camera is opened with default user set, the camera works in continuous mode directly. Otherwise, user can set **Trigger Mode OFF** to use continuous mode.

Other parameters also can be changed in **Trigger Mode OFF**.

- Continuous mode features

In continuous acquisition mode, the camera captures and transfers images according to camera parameter settings.



In continuous mode, ROI size, bandwidth limitation and exposure time may have effects on frame rate.

#### 8.2.5. Software Trigger Acquisition and Configuration

- **Software trigger acquisition configuration**

The camera supports software trigger acquisition mode. Three steps followed should be ensured.

- 1) Set the Trigger Mode to ON.
- 2) Set the Trigger Source to Software.
- 3) Send Software Trigger command.

All the software trigger commands are sent by the host through the USB3.0 bus, to trigger the camera to acquire and transmit images.

- **Software trigger acquisition features**

In software trigger acquisition mode, the camera begins to acquire one image after receiving software trigger commands. In general, the number of frames is equal to the number of software trigger commands. The relative features are illustrated below:

- 1) In software trigger acquisition mode, if the trigger frequency is lower than permissible maximal FPS (Frame per Second) of the camera, the current frame rate is trigger frequency. If the trigger frequency is higher than permissible maximal FPS (Frame per Second) of the camera, some software triggers are ignored and the current frame rate is lower than trigger frequency.
- 2) The trigger delay feature can control the camera delay interval between your triggers and the camera acquiring frames. The default value of trigger delay time is zero.

### 8.2.6. External Trigger Acquisition and Configuration

- **External trigger acquisition configuration**

The camera supports external trigger acquisition mode. Three steps followed should be ensured:

- 1) Set the Trigger Mode to ON.
- 2) Set the Trigger Source to Line0, Line2 or Line3.
- 3) Connect external trigger signal to Line0.

If the Trigger Source is set by Line2 or Line3, it should be ensured that the corresponding Line is set as Input.

Please refer to [section 8.1.1](#) for more information of the programmable GPIOs.

- **External Trigger acquisition features**

The relative features about the camera's trigger signal process are illustrated below:

- 1) The polarity of lines can be set to inverted or not inverted, and the default setting is not inverted.
- 2) Improper signal can be filtered by setting appropriate value to trigger filter. Raising edge filter and falling edge can be set separately. The range is from 0 to 5000 us. The default configuration is not use trigger filter.
- 3) The time interval between trigger and exposure can be set through the trigger delay feature. The range of time interval covers from 0 to 3000000μs. The default value of trigger delay time is zero.

The features, like trigger polarity, trigger delay and trigger filter, can be select in the GalaxyView.



The camera's trigger source Line0 uses opto-isolated circuit to isolate signal. Its internal circuit delay trigger signal and rising edge's delay time is less than falling edge's. There are a dozen clock cycles delay of rising edge and dozens clock cycles delay of falling edge. If you use Line0 to trigger the camera, the positive pulse signal's positive width will be wider (about 20-40μs) and the negative pulse signal's negative width will be narrower (about 20-40μs). You can adjust filter parameter to accurately filter trigger signal.

There is small difference among there models of MER-U3 camera. These camera's different time intervals are shown below:

Camera model	GPIO delay time	opto-coupler delay time
MER-031-860U3M/C	Non-overlap/Overlap: 4μs	Non-overlap/Overlap: 8-12μs
MER-031-860U3M NIR	Non-overlap/Overlap: 4μs	Non-overlap/Overlap: 8-12μs
MER-041-436U3M/C	Non-overlap: 0.16μs Overlap: (0.16~4.08) μs	Non-overlap: 4.16~8.16μs Overlap: (4.16~12.08) μs
MER-050-560U3M/C	Non-overlap/Overlap: 4μs	Non-overlap/Overlap: 8-12μs

MER-050-560U3M NIR	Non-overlap/Overlap: 4μs	Non-overlap/Overlap: 8-12μs
MER-051-120U3M/C	Non-overlap: 4μs Overlap: 16.3-29.4μs	Non-overlap: 8-12μs Overlap: 20.3-37.4μs
MER-131-210U3M/C	Non-overlap: 4μs Overlap: 25-32μs	Non-overlap: 8-12μs Overlap: 30-40μs
MER-131-210U3M NIR	Non-overlap: 4μs Overlap: 25-32μs	Non-overlap: 8-12μs Overlap: 30-40μs
MER-132-43U3M/C	Non-overlap: 0.55μs Overlap: (0.55~24.1) μs	Non-overlap: 4.55~8.55μs Overlap: (4.55~32.1) μs
MER-133-54U3M/C	183μs	187μs ~191μs
MER-134-93U3M/C	Non-overlap: 4μs Overlap: 27.6-37.9μs	Non-overlap: 8-12μs Overlap: 31.6-45.9μs
MER-160-227U3M/C	Non-overlap: 0.16μs Overlap: (0.16~8) μs	Non-overlap: 4.16~8.16μs Overlap: (4.16~16) μs
MER-230-168U3M/C	Non-overlap: 0.16μs Overlap: (0.16~9.76) μs	Non-overlap: 4.16~8.16μs Overlap: (4.16~17.76) μs
MER-231-41U3M/C	Non-overlap: 0.16μs Overlap: (0.16~20) μs	Non-overlap: 4.16~8.16μs Overlap: (4.16~28) μs
MER-301-125U3M/C	Non-overlap: 0.16μs Overlap: (0.16~10.29) μs	Non-overlap: 4.16~8.16μs Overlap: (4.16~18.29) μs
MER-302-56U3M/C	Non-overlap: 0.16μs Overlap: (0.16~11.44) μs	Non-overlap: 4.16~8.16μs Overlap: (4.16~19.44) μs
MER-500-14U3M/C	Non-overlap: 292μs Overlap: 292±36μs	Non-overlap: 296-300μs Overlap: 296-300±36μs
MER-502-79U3M/C	Non-overlap: 0.16μs Overlap: (0.16~12.27) μs	Non-overlap: 4.16~8.16μs Overlap: (4.16~20.27) μs
MER-502-79U3M POL	Non-overlap: 0.16μs Overlap: (0.16~12.27) μs	Non-overlap: 4.16~8.16μs Overlap: (4.16~20.27) μs
MER-503-36U3M/C	Non-overlap: 0.16μs Overlap: (0.16~13.44) μs	Non-overlap: 4.16~8.16μs Overlap: (4.16~21.44) μs
MER-630-60U3M/C	BayerRG8/Mono8: 2357us BayerRG10/Mono10: 2707us	BayerRG8/Mono8: 2361-2365us BayerRG10/Mono10: 2711-2715us
MER-1070-14U3M/C	5250±25μs	5254-5258±25μs
MER-1220-32U3M/C	BayerRG8/Mono8: 650us BayerRG12/Mono12: 1260us	BayerRG8/Mono8: 654-658us BayerRG12/Mono12: 1264-1268us
MER-1520-13U3C	5800±150μs	5804-5808±150μs
MER-1810-21U3C	BayerGR8: 2.7ms BayerGR12: 3.3ms	BayerGR8: 2.7ms BayerGR12: 3.3ms
MER-2000-19U3M/C	BayerRG8/Mono8: 800us BayerRG12/Mono12: 1550us	BayerRG8/Mono8: 804-808us BayerRG12/Mono12: 1554-1558us

Table 8-2 Different time intervals of MER-U3 series Camera

### 8.2.7. Set Exposure

- **Global Shutter**

Model	Sensor Type
MER-031-860U3M/C(-L)/MER-031-860U3M(-L) NIR/MER-041-436U3M/C(-L)/ MER-050-560U3M/C(-L)/MER-050-560U3M(-L) NIR/MER-051-120U3M/C(-L)/ MER-131-210U3M/C(-L)/MER-131-210U3M(-L) NIR/MER-132-43U3M/C(-L)/ MER-131-210U3M/C(-L)/MER-134-93U3M/C(-L)/MER-160-227U3M/C(-L)/ MER-230-168U3M/C(-L)/MER-231-41U3M/C(-L)/MER-301-125U3M/C(-L)/ MER-302-56U3M/C(-L)/MER-502-79U3M/C(-L)/MER-502-79U3M(-L) POL/ MER-503-36U3M/C(-L)	Global Shutter

Table 8-3 Global Shutter camera models

The implementation process of global shutter sensor is as shown in Figure 8-14, all the lines of the sensor are exposed at the same time, and then the sensor will read out the image data one by one.

The advantage of the global shutter sensor is that all the lines are exposed at the same time, and the images do not appear offset and distortion when capturing moving objects.

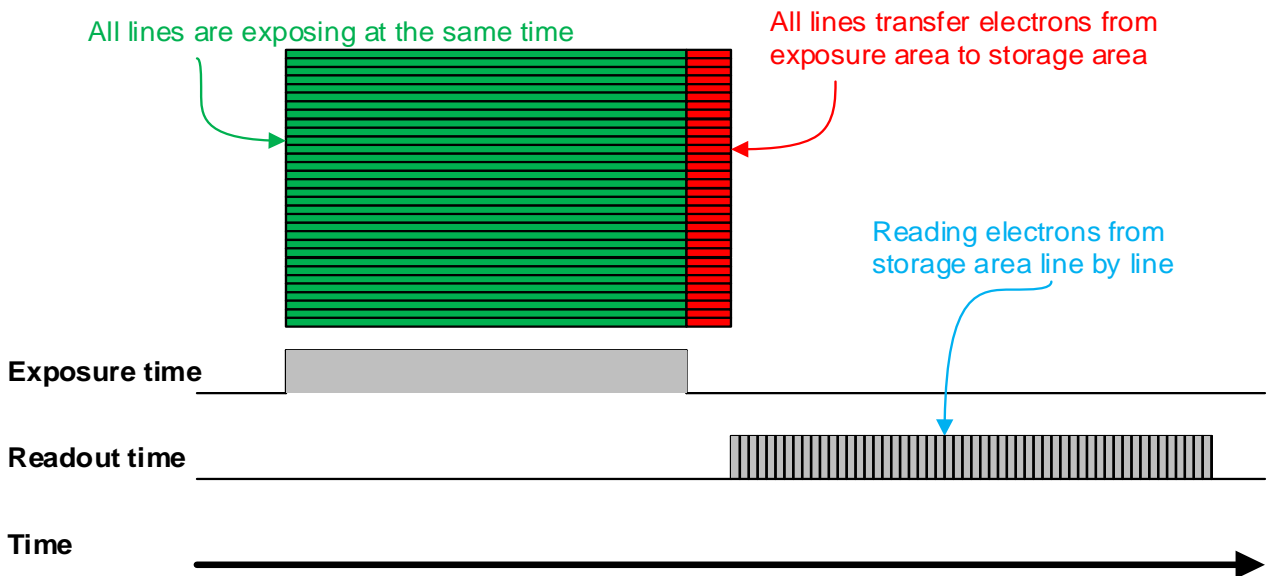

Figure 8-14 Global shutter



● **Electronic Rolling Shutter**

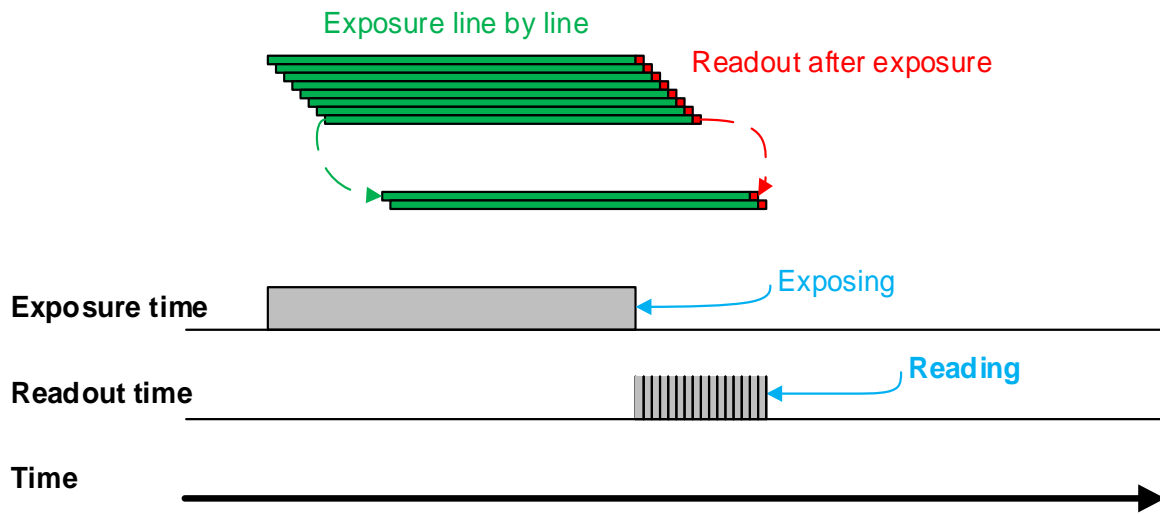

Figure 8-15 Electronic rolling shutter

Model	Sensor Type
MER-500-14U3M/C(-L)/MER-1070-14U3M/C(-L)/ MER-1520-13U3C(-L)/MER-1810-21U3C(-L)/ MER-630-60U3M/C(-L)/MER-2000-19U3M/C(-L)/ MER-1220-32U3M/C(-L)	Electronic rolling shutter

Table 8-4 Electronic rolling shutter camera models

The implementation process of electronic rolling shutter is as shown in Figure 8-15, different from the global shutter, electronic rolling shutter exposures from the first line, and starts the second line exposure after a row period. And so on, after N-1 line, the N line starts exposing. When the first line exposure ends, it begins to read out the data, and it need a row period time to read out one line (including the line blanking time). When the first line reads out completely, the second line just begins to read out, and so on, when the N-1<sup>th</sup> line is read out, the N<sup>th</sup> line begins to read out, until the whole image is read out completely.

The electronic rolling shutter has low price and high resolution, which is a good choice for some static image acquisition.

● **Setting the exposure time**

The MER-U3 series camera supports setting the exposure time, step: 1 $\mu$ s. The exposure time is shown as follows:

Model	Exposure Mode	Exposure Time Range( $\mu$ s)	Steps( $\mu$ s)
MER-031-860U3M/C(-L)	Global Shutter	20-1000000	1
MER-031-860U3M(-L) NIR	Global Shutter	20-1000000	1
MER-041-436U3M/C(-L)	Global Shutter	20-1000000	1
MER-050-560U3M/C(-L)	Global Shutter	20-1000000	1

MER-050-560U3M(-L) NIR	Global Shutter	20-1000000	1
MER-051-120U3M/C(-L)	Global Shutter	5-1000000	1
MER-131-210U3M/C(-L)	Global Shutter	20-1000000	1
MER-131-210U3M(-L) NIR	Global Shutter	20-1000000	1
MER-132-43U3M/C(-L)	Global Shutter	20-1000000	1
MER-131-210U3M/C(-L)	Global Shutter	20-1000000	1
MER-134-93U3M/C(-L)	Global Shutter	5-1000000	1
MER-160-227U3M/C(-L)	Global Shutter	20-1000000	1
MER-230-168U3M/C(-L)	Global Shutter	20-1000000	1
MER-231-41U3M/C(-L)	Global Shutter	20-1000000	1
MER-301-125U3M/C(-L)	Global Shutter	20-1000000	1
MER-302-56U3M/C(-L)	Global Shutter	20-1000000	1
MER-500-14U3M/C(-L)	Electronic Rolling Shutter	36-1000000	1
MER-502-79U3M/C(-L)	Global Shutter	20-1000000	1
MER-502-79U3M(-L) POL	Global Shutter	20-1000000	1
MER-503-36U3M/C(-L)	Global Shutter	20-1000000	1
MER-630-60U3M/C(-L)	Electronic Rolling Shutter	8-1000000	1
MER-1070-14U3M/C(-L)	Electronic Rolling Shutter	24-1000000	1
MER-1220-32U3M/C(-L)	Electronic Rolling Shutter	10-1000000	1
MER-1520-13U3C(-L)	Electronic Rolling Shutter	22-1000000	1
MER-1810-21U3C(-L)	Electronic Rolling Shutter	20-1000000	1
MER-2000-19U3M/C(-L)	Electronic Rolling Shutter	12-1000000	1

Table 8-5 MER-U3 series camera exposure time setting range

When the external light source is sunlight or direct current (DC), the camera has no special requirements for the exposure time. When the external light source is alternating current (AC), the exposure time must synchronize with the external light source (under 50Hz light source, the exposure time must be a multiple of 1/100s, under 60Hz light source, the exposure time must be a multiple of 1/120s), to ensure better image quality. You can set the exposure time that is synchronized with the external light source by using the demo or interface function.

The MER-U3 series camera supports Auto Exposure feature. If the Auto Exposure feature is enabled, the camera can adjust the exposure time automatically according to the environment brightness. See [section 8.3.4](#) for more details.

### 8.2.8. Overlapping Exposure and Non-overlapping Exposure

There are two stages in image acquisition of the MER-U3 series camera: exposure and readout. Once the camera is triggered, it begins to integrate and when the integration is over, the image data will be read out immediately.

The MER-U3 series camera supports two exposure modes: overlapping exposure and non-overlapping exposure. The user cannot assign the overlapping exposure or non-overlapping exposure directly, it depends on the frequency of trigger signal and the exposure time. The two exposure mode are described as below.

- **Non-overlapping exposure**

In non-overlapping exposure mode, after the exposure and readout of the current frame are completed, then the next frame will expose and read out. As shown in the Figure 8-16, the N<sup>th</sup> frame is read out, after a period of time, the N+1<sup>th</sup> frame to be exposed.

The formula of non-overlapping exposure frame period:

$$\text{non-overlapping exposure frame period} > \text{exposure time} + \text{readout time}$$

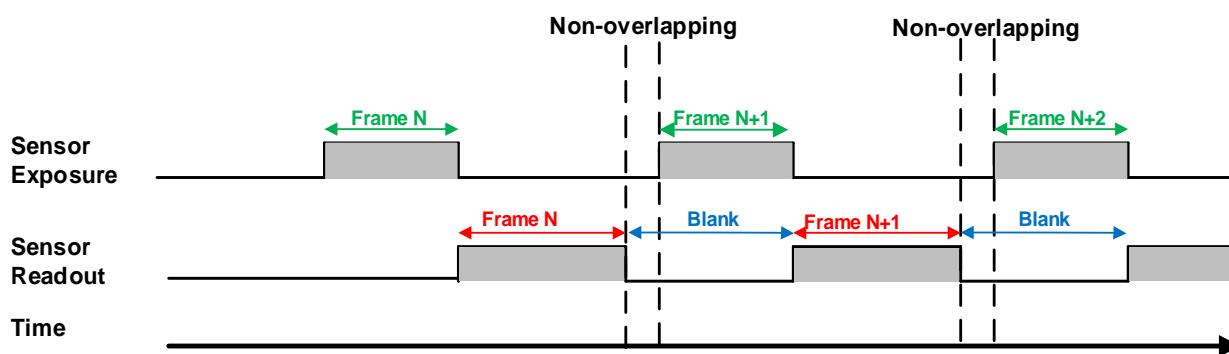

Figure 8-16 The exposure sequence diagram in non-overlapping exposure mode

- **Trigger acquisition mode**

If the interval between two triggers is greater than the sum of the exposure time and readout time, overlapping exposure will not occur, as shown in Figure 8-17.

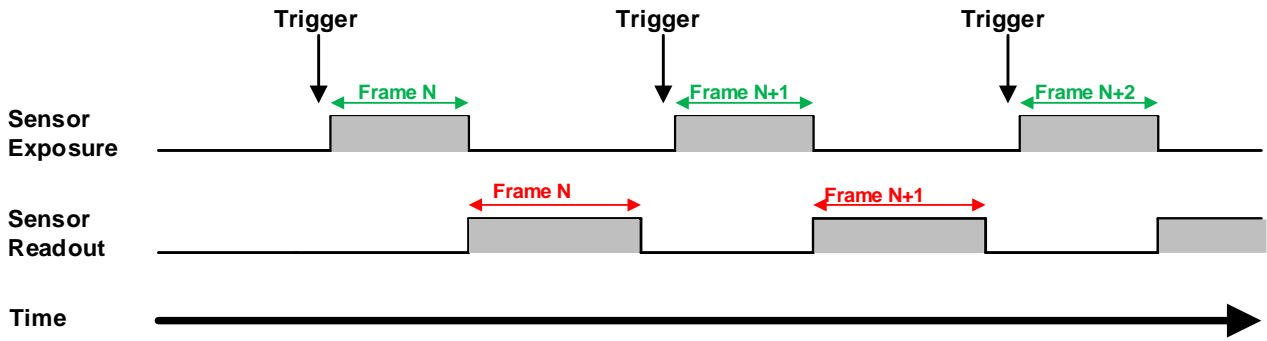

Figure 8-17 The trigger acquisition exposure sequence diagram in non-overlapping exposure mode

● **Overlapping exposure**

In overlapping exposure mode, the current frame image exposure process is overlap with the readout of the previous frame. That is, when the previous frame is reading out, the next frame image has been started exposure. As shown in the Figure 8-18, when the N<sup>th</sup> frame image is reading out, the N+1<sup>th</sup> frame image has been started exposure.

The formula of overlapping exposure frame period:

$$\text{overlapping exposure frame period} \leq \text{exposure time} + \text{readout time}$$

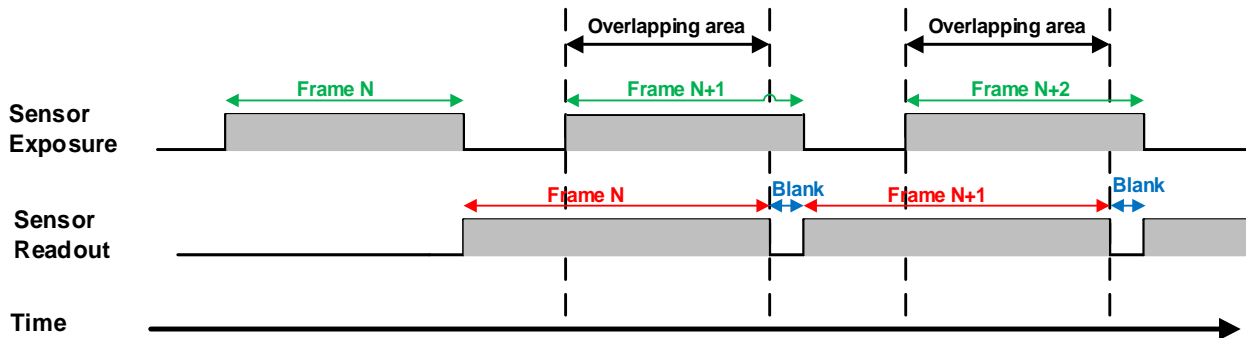

Figure 8-18 The exposure sequence diagram in overlapping exposure mode

● **Continuous acquisition mode**

If the exposure time is greater than the frame blanking time, the exposure time and the readout time will be overlapped. As shown in the Figure 8-18.

● **Trigger acquisition mode**

When the interval between two triggers is less than the sum of exposure time and the readout time, overlapping exposure will occur, as shown in Figure 8-19.

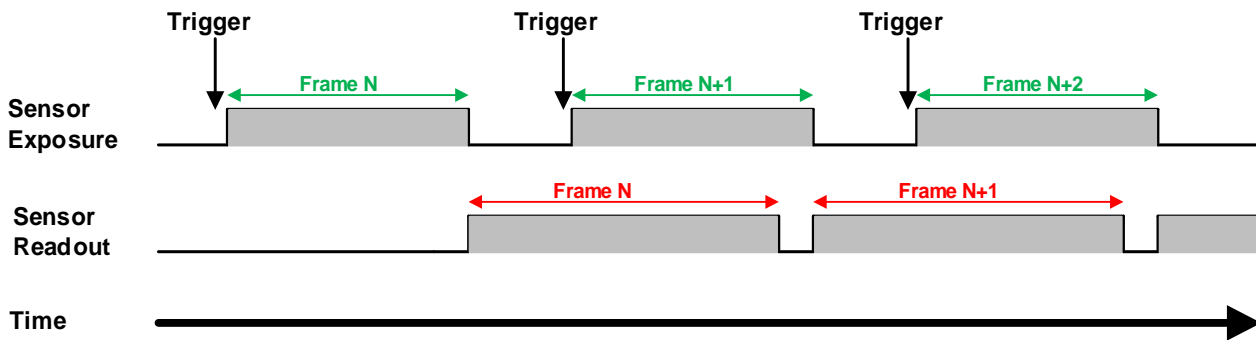

Figure 8-19 The trigger acquisition exposure sequence diagram in overlapping exposure mode

Compared with non-overlapping exposure mode, in overlapping exposure mode, the camera can obtain higher frame rate.



MER-131-210U3M/C(-L) , MER-630-60U3M/C(-L), MER-1070-14U3M/C(-L), MER-1220-32U3M/C(-L), MER-1520-13U3C(-L), MER-1810-21U3C(-L), MER-2000-19U3M/C(-L), these cameras only support non-overlapping exposure in trigger mode. When the trigger delay is less than the frame period, some trigger signals will be shield.

### 8.2.9. Strobe

Strobe is one of the ways to adjust the brightness of the image, which is a lot different from a global shutter camera and an electronic rolling shutter camera, especially in strobe control.

All the lines of the global shutter camera are exposed at the same time, and it is simple to supplement light, and the camera can get the same brightness images as long as the strobe is light during the exposure of the camera. The width of the flash signal is equal to the exposure time. The width of the flash signal can be obtained by the following formula:

$$T_{\text{strobe}} = T_{\text{exposure}}$$

The figure below identifies the exposure time of the global exposure product.

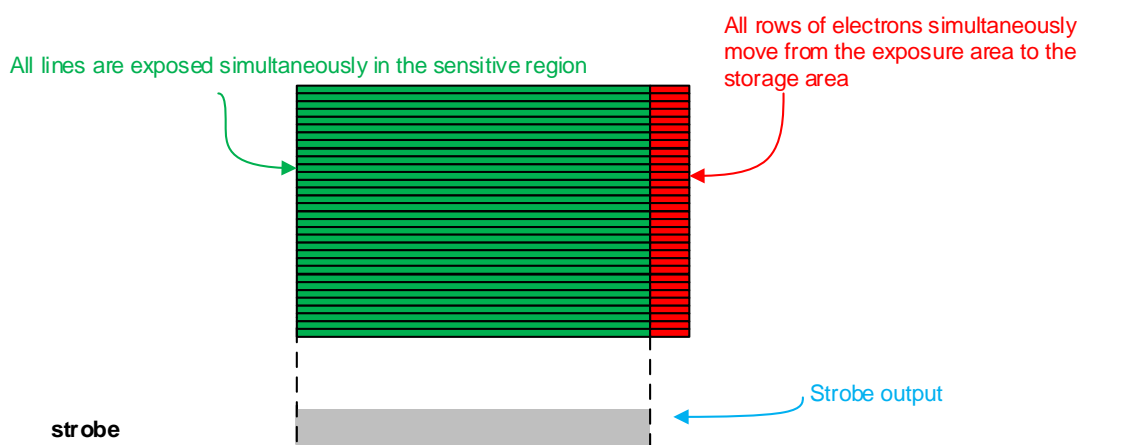

Figure 8-20 The relationship between strobe width and exposure time in global shutter mode

The global shutter sensors of MER-U3 series camera are as follows models:

Model	Sensor Type
MER-031-860U3M/C(-L)/MER-031-860U3M(-L) NIR/MER-041-436U3M/C(-L) /MER-050-560U3M/C(-L)/MER-050-560U3M(-L) NIR/MER-051-120U3M/C(-L) /MER-131-210U3M/C(-L)/MER-131-210U3M(-L) NIR/MER-132-43U3M/C(-L) /MER-131-210U3M/C(-L)/MER-134-93U3M/C(-L)//MER-160-227U3M/C(-L) /MER-230-168U3M/C(-L)/MER-231-41U3M/C(-L)/MER-301-125U3M/C(-L)/MER-302-56U3M/C(-L)/MER-502-79U3M/C(-L)/MER-502-79U3M(-L) POL/MER-503-36U3M/C(-L)	Global Shutter

Table 8-6 Global Shutter camera models

Because all the lines of electronic rolling shutter camera are exposed not at the same time, it is difficult to use flash light. The strobe is light only during all the lines at the same time exposure and no photons into the sensor at the other time, the camera can get consistent brightness image. If the strobe is light too early, the image above will be bright, if the strobe is delay to extinguish, the image below will brighter. The width of the flash signal can be obtained by the following formula:

$$T_{\text{strobe}} = T_{\text{exposure}} - (N - 1) * T_{\text{row}}$$

The following figure identifies the moment when the MER-500-14U3M/C(-L) electronic rolling shutter camera exposing:

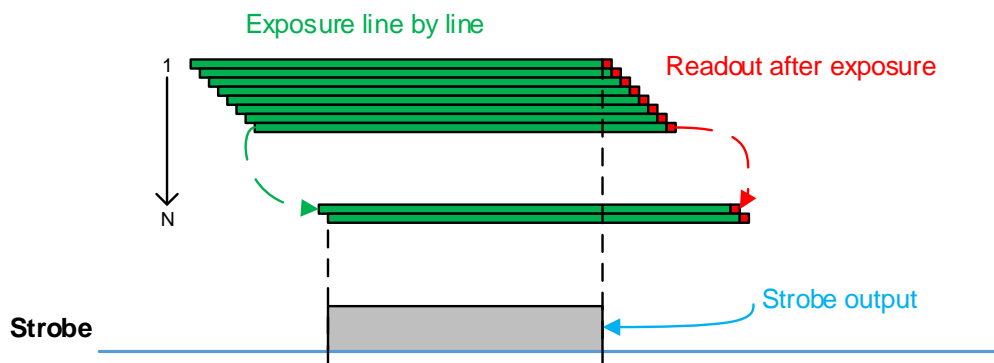

Figure 8-21 The relationship between strobe width and exposure time in rolling shutter mode

The MER-500-14U3M/C(-L) camera output a strobe signal when all the lines are exposed at the same time, and does not output the strobe signal at other stages. Therefore, when the exposure time is less than the preset frame period (approximately equal to readout time), there is no strobe output, and the flash light is off.

Example:

When the camera is at the full resolution, the bandwidth limit is closed, if set the exposure time as 100ms, then the preset frame period is about 71.5ms, the signal width of strobe is 28.5ms, if change the exposure time to 70ms, then no strobe signal output, because all the lines are not exposed at the same time.

## 8.3. Basic Features

### 8.3.1. Gain

The MER-U3 series camera can adjust the analog gain, and the range of analog gain is as follows:

Model	Adjustment range	Default/Steps
MER-031-860U3M/C(-L)	0-16dB	0dB, 0.1dB
MER-031-860U3M(-L) NIR	0-16dB	0dB, 0.1dB
MER-041-436U3M/C(-L)	0-24dB	0dB, 0.1dB
MER-050-560U3M/C(-L)	0-16dB	0dB, 0.1dB
MER-050-560U3M(-L) NIR	0-16dB	0dB, 0.1dB
MER-051-120U3M/C(-L)	0-16dB	0dB, 0.1dB
MER-131-210U3M/C(-L)	0-16dB	0dB, 0.1dB
MER-131-210U3M(-L) NIR	0-16dB	0dB, 0.1dB
MER-132-43U3M/C(-L)	0-25dB	0dB, 0.1dB
MER-131-210U3M/C(-L)	0-31dB	0dB, 0.1dB
MER-134-93U3M/C(-L)	0-16dB	0dB, 0.1dB
MER-160-227U3M/C(-L)	0-24dB	0dB, 0.1dB
MER-230-168U3M/C(-L)	0-24dB	0dB, 0.1dB
MER-231-41U3M/C(-L)	0-24dB	0dB, 0.1dB
MER-301-125U3M/C(-L)	0-24dB	0dB, 0.1dB
MER-302-56U3M/C(-L)	0-24dB	0dB, 0.1dB
MER-500-14U3M/C(-L)	0-17dB	0dB, 0.1dB

MER-502-79U3M/C(-L)	0-24dB	0dB, 0.1dB
MER-502-79U3M(-L) POL	0-24dB	0dB, 0.1dB
MER-503-36U3M/C(-L)	0-24dB	0dB, 0.1dB
MER-630-60U3M/C(-L)	0-24dB	0dB, 0.1dB
MER-1070-14U3M/C(-L)	0-25.9dB	0dB, 0.1dB
MER-1220-32U3M/C(-L)	0-24dB	0dB, 0.1dB
MER-1520-13U3C(-L)	0-22.5dB	0dB, 0.1dB
MER-1810-21U3C(-L)	0-20dB	0dB, 0.1dB
MER-2000-19U3M/C(-L)	0-24dB	0dB, 0.1dB

Table 8-7 MER-U3 series camera analog gain adjustment range

When the analog gain changes, the response curve of the camera changes, as shown in Figure 8-22. The horizontal axis represents the output signal of the sensor in the camera, and the vertical axis represents the gray value of the output image. When the amplitude of the sensor output signal remains constant, increasing the gain makes the response curve steeper, and that makes the image brighter. For every 6dB increases of the gain, the gray value of the image will double. For example, when the camera has a gain of 0dB, the image gray value is 126, and if the gain is increased to 6dB, the image gray will increase to 252. Note that increasing the analog gain or digital gain will amplify the image noise.

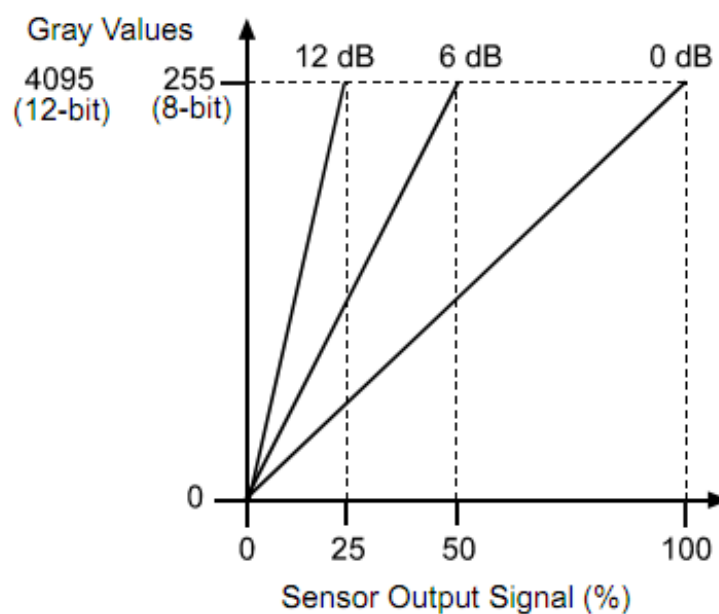

Figure 8-22 The cameras response curve



### 8.3.2. Pixel Format

By setting the pixel format, the user can select the format of output image. The available pixel formats depend on the camera model and whether the camera is monochrome or color. The following table shows the pixel format supported by the camera.

Model	Pixel Format
MER-031-860U3M/C(-L)	Mono8, Mono10, BayerRG8, BayerRG10
MER-031-860U3M(-L) NIR	Mono8, Mono10
MER-041-436U3M/C(-L)	Mono8, Mono10, BayerRG8, BayerRG10
MER-050-560U3M/C(-L)	Mono8, Mono10, BayerRG8, BayerRG10
MER-050-560U3M(-L) NIR	Mono8, Mono10
MER-051-120U3M/C(-L)	Mono8, Mono10, BayerRG8, BayerRG10
MER-131-210U3M/C(-L)	Mono8, Mono10, BayerRG8, BayerRG10
MER-131-210U3M(-L) NIR	Mono8, Mono10
MER-132-43U3M/C(-L)	Mono8, Mono12, BayerRG8, BayerRG12
MER-131-210U3M/C(-L)	Mono8, Mono10, BayerRG8, BayerRG10
MER-134-93U3M/C(-L)	Mono8, Mono10, BayerRG8, BayerRG10
MER-160-227U3M/C(-L)	Mono8, Mono10, BayerRG8, BayerRG10
MER-230-168U3M/C(-L)	Mono8, Mono10, BayerRG8, BayerRG10
MER-231-41U3M/C(-L)	Mono8, Mono10, BayerRG8, BayerRG10
MER-301-125U3M/C(-L)	Mono8, Mono10, BayerRG8, BayerRG10
MER-302-56U3M/C(-L)	Mono8, Mono10, BayerRG8, BayerRG10
MER-500-14U3M/C(-L)	Mono8, Mono10, BayerGR8, BayerGR10
MER-502-79U3M/C(-L)	Mono8, Mono10, BayerRG8, BayerRG10

MER-502-79U3M(-L) POL	Mono8, Mono10
MER-503-36U3M/C(-L)	Mono8, Mono10, BayerRG8, BayerRG10
MER-630-60U3M/C(-L)	Mono8, Mono10, BayerRG8, BayerRG10
MER-1070-14U3M/C(-L)	Mono8, Mono12, BayerGR8, BayerGR12
MER-1220-32U3M/C(-L)	Mono8, Mono12, BayerRG8, BayerRG12
MER-1520-13U3C(-L)	BayerGR8, BayerGR12
MER-1810-21U3C(-L)	BayerGR8, BayerGR12
MER-2000-19U3M/C(-L)	Mono8, Mono12, BayerRG8, BayerRG12

Table 8-8 Pixel format that the MER-U3 series camera supported

The image data starts from the upper left corner, and each pixel is output brightness value of each pixel line from left to right and from top to bottom.

- Mono8

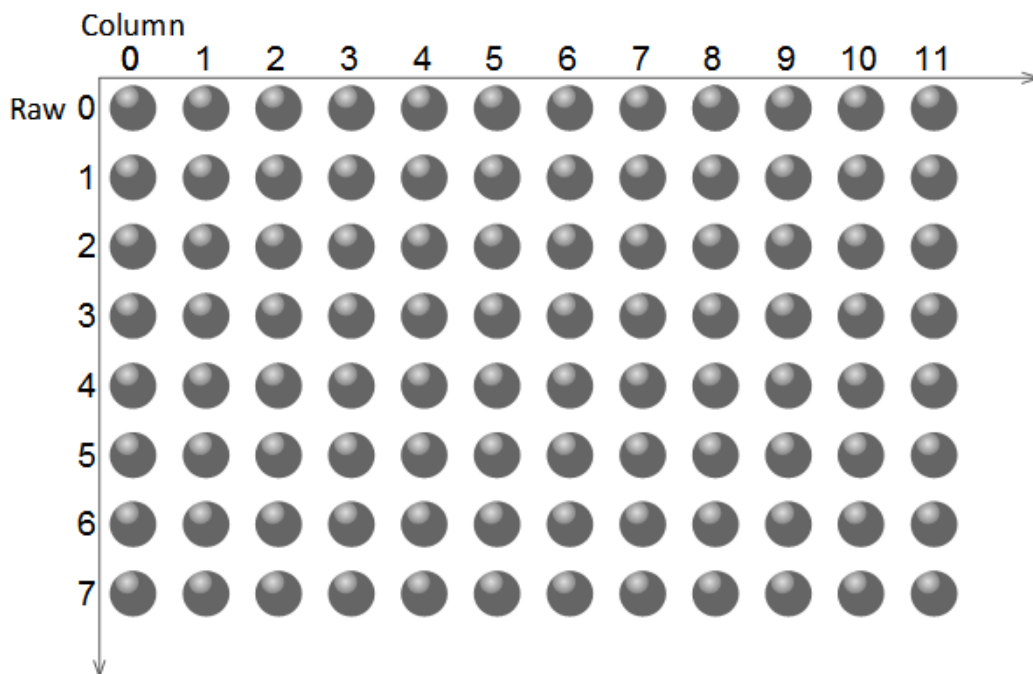

Figure 8-23 Mono8 pixel format

When the pixel format is set to Mono8, the brightness value of each pixel is 8 bits. The format in the memory is as follows:

Y00	Y01	Y02	Y03	Y04	.....
-----	-----	-----	-----	-----	-------

Y10	Y11	Y12	Y13	Y14	.....
.....					

Among them Y00, Y01, Y02 ... are the gray value of each pixel that starts from the first row of the image. Then the gray value of the second row pixels of the images is Y10, Y11, and Y12...

● **Mono10/Mono12**

When the pixel format is set to mono10 or Mono12, each pixel is 16 bits. When Mono10 is selected, the effective data is only 10 bits, the six unused most significant bits are filled with zero. When Mono12 is selected, the effective data is only 12 bits, the 4 of the MSB 16 bits data are set to zero. Note that the brightness value of each pixel contains two bytes, arranged in little-endian mode. The format is as follows:

Y00	Y01	Y02	Y03	Y04	.....
Y10	Y11	Y12	Y13	Y14	.....
.....					

Among them Y00, Y01, Y02...are the gray value of each pixel that start with the first row of the image. The first byte of each pixel is low 8 bits of brightness, and the second byte of each pixel is high 8 bits of brightness.

● **BayerGR8**

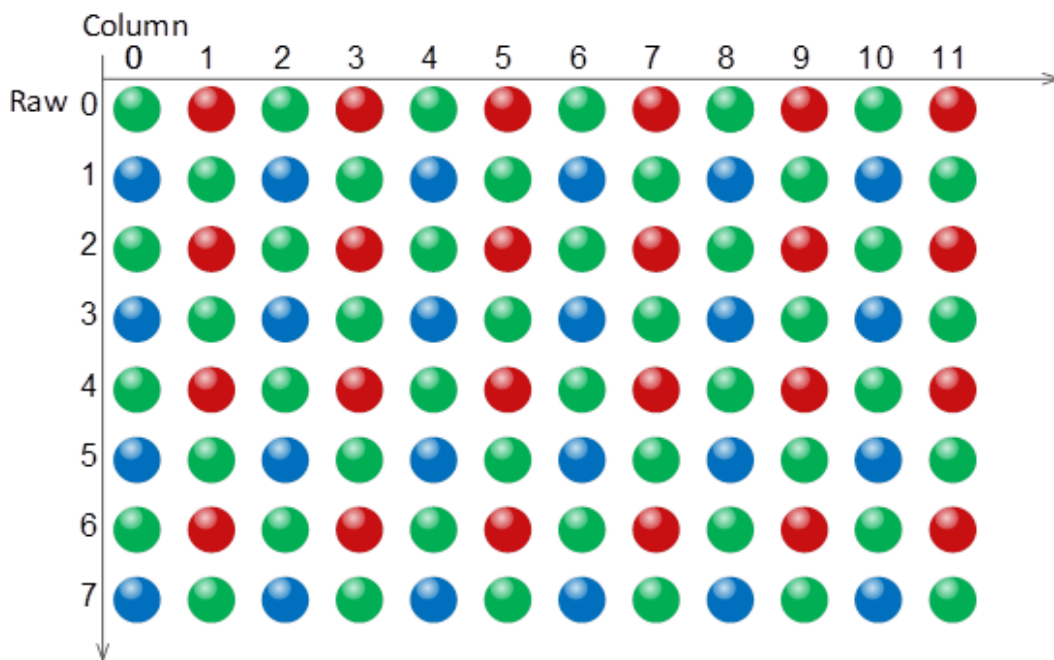

Figure 8-24 BayerGR8 pixel format

When the pixel format is set to BayerGR8, the value of each pixel in the output image of the camera is 8 bits. According to the location difference, the three components of red, green and blue are respectively represented. The format in the memory is as follows:

G00	R01	G02	R03	G04	.....
-----	-----	-----	-----	-----	-------

B10	G11	B12	G13	B14	.....
.....					

Where G00 is the first pixel value of the first row (for the green component), R01 represents the second pixel value (for the red component), and so on, so that the first row pixel values are arranged. B10 is the first pixel value of the second row (for the blue component), the G11 is the second pixel value (for the green component), and so on, and the second row of pixel values are arranged.

● **BayerGR10/BayerGR12**

When the pixel format is set to BayerGR10 or BayerGR12, the value of each pixel in the output image of the camera is 16 bits. According to the location difference, the three components of red, green and blue are respectively represented. The format in the memory is as follows:

G00	R01	G02	R03	G04	.....
B10	G11	B12	G13	B14	.....
.....					

Each pixel is the same as BayerGR8, the difference is that each pixel is made up of two bytes, the first byte is the low 8 bits of the pixel value, and the second byte is the high 8 bits of the pixel value.



When changing the pixel format, the device should stop acquisition.

8.3.3. ROI

By setting the ROI of the image, the camera can transmit the specific region of the image, and the output region's parameters include OffsetX, OffsetY, width and height of the output image. The camera only reads the image data from the sensor's designated region to the memory, and transfer it to the host, and the other regions' image of the sensor will be discarded.

By default, the image ROI of the camera is the full resolution region of the sensor. By changing the OffsetX, OffsetY, width and height, the location and size of the image ROI can be changed. The OffsetX refers to the starting column of the ROI, and the OffsetY refers to the starting row of the ROI. Among them, the step of OffsetX and width is 4, and the step of OffsetY and height is 2.

The coordinates of the ROI of the image are defined the 0<sup>th</sup> raw and 0<sup>th</sup> column as the origin of the upper left corner of the sensor. As shown in the figure, the OffsetX of the ROI is 4, the OffsetY is 4, the height is 8 and the width is 12.

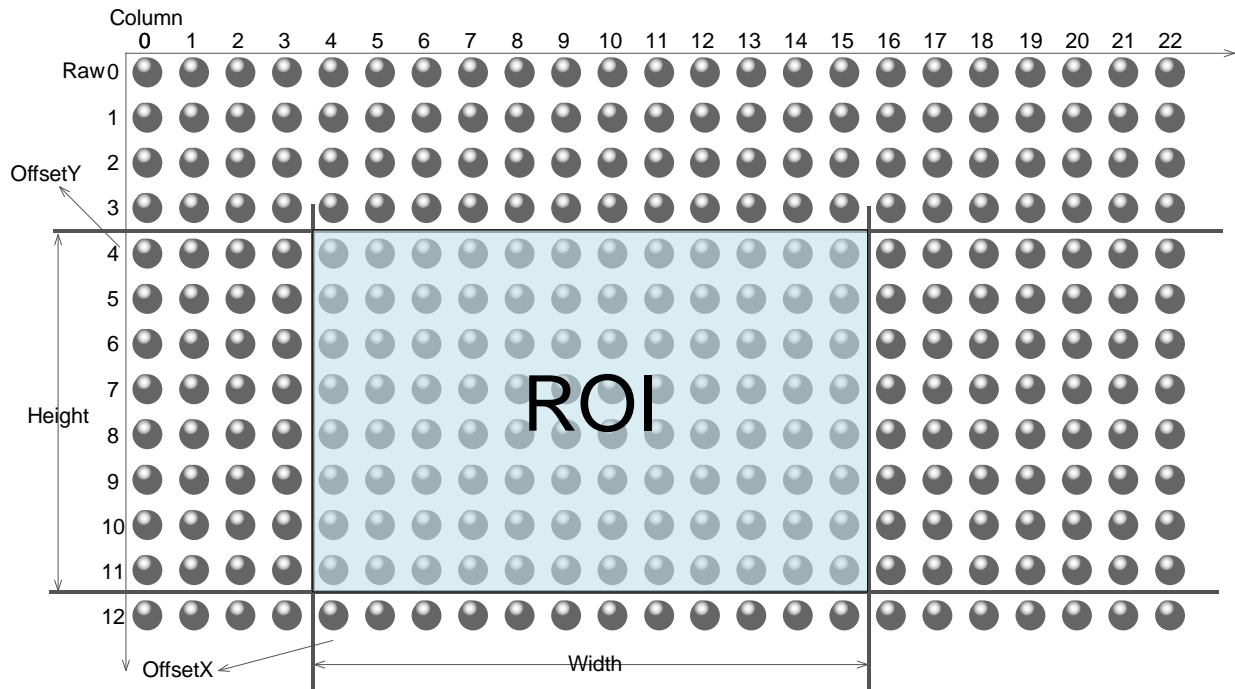

Figure 8-25 ROI

When reducing the height of the ROI, the maximum frame rate of the camera will be raised. Please refer to [section 8.5.1](#) for specific effects on the acquisition frame rate.



When setting the ROI of the image, the device should stop acquisition.

### 8.3.4. Auto Exposure/Auto Gain

#### 8.3.4.1. ROI Setting of Auto Exposure/Auto Gain

For Auto Exposure and Auto Gain, you can specify a portion of the sensor array and only the pixel data from the specified portion will be used for auto function control.

AAROI is defined by the following way:

AAROIOffsetX: The offset of the X axis direction.

AAROIOffsetY: The offset of the Y axis direction.

AAROIWidth: The width of ROI.

AAROIHeight: The height of ROI.

Offset is the offset value that relative to the upper left corner of the image. The step of AAROIOffsetX and AAROIWidth is 4. The step of AAROIOffsetY and AAROIHeight is 2. The setting of the AAROI depends on the size of the current image and cannot exceed the range of the current image. That is to say, assuming the Width and Height are parameters for users captured image, then the AAROI setting need to meet the condition 1:

$$\text{AAROIWidth} + \text{AAROIOffsetX} \leq \text{Width}$$

$$AAROIHeight + AAROIOffsetY \leq Height$$

If condition 1 is not met, the user cannot set the ROI.

The default value of ROI is the entire image, you can set the ROI according to your need. Where the minimum value of AAROIWidth can be set to 16, and the maximum value is equal to the current image width. The minimum value of AAROIHeight can be set to 16, and the maximum value is equal to the current image height, they are all need to meet the condition1.

For example: the current image width is 1024, the height is 1000, and then the ROI setting is:

$$AAROIOffsetX = 100$$

$$AAROIOffsetY = 50$$

$$AAROIWidth = 640$$

$$AAROIHeight = 480$$

The relative position of the ROI and the image is shown in Figure 8-26.

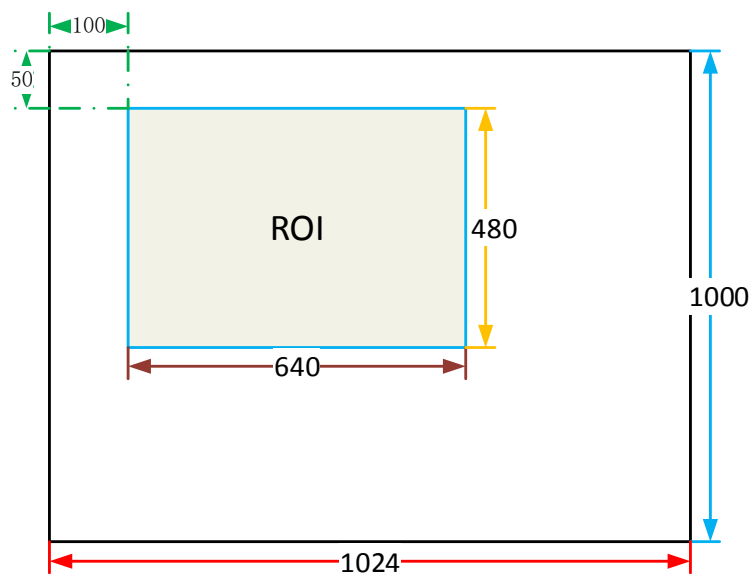

Figure 8-26 An example for the relative position between the ROI and the current image

#### 8.3.4.2. Auto Gain

The auto gain can adjust the camera's gain automatically, so that the average gray value in AAROI is achieved to the expected gray value. The auto gain can be controlled by "Once" and "Continuous" mode.

When using the "Once" mode, the camera adjusts the image data in the AAROI to the expected gray value once, then the camera will turn off the auto gain feature. When using the "Continuous" mode, the camera will continuous adjust the gain value according to the data of the AAROI, so that the data in the AAROI is kept near to the expected gray level.

The expected gray value is set by the user, and it is related to the data bit depth. For 8bit pixel data, the expected gray value range is 0-255, for 10bit pixel data, the expected gray value range is 0-1023.

The camera adjusts the gain value within the range [minimum gain value, maximum gain value] which is set by the user.

The auto gain feature can be used with the auto exposure at the same time, when target grey is changed from dark to bright, the auto exposure adjust is prior to auto gain adjust. Vice versa, when target grey is changed from bright to dark, the auto gain adjust is prior to auto exposure adjust.

#### 8.3.4.3. Auto Exposure

The auto exposure can adjust the camera's exposure time automatically, so that the average gray value in AAROI can achieve to the expected gray value. The auto exposure can be controlled by "Once" and "Continuous" mode.

When using the "Once" mode, the camera adjusts the image data in the AAROI to the expected gray value once, then the camera will close the auto exposure feature. When using the "Continuous" mode, the camera will continuous adjusting the exposure time according to the data of the AAROI, so that the data in the AAROI is kept near to the expected gray level.

The expected gray value is set by the user and it is related to the data bit depth. For 8bit pixel data, the expected gray value range is 0-255, for 10bit pixel data, the expected gray value range is 0-1023, and for 12bit pixel data, the expected gray value range is 0-4095.

The camera adjusts the exposure time in the range [minimum exposure time, maximum exposure time] which is set by the user.

The auto exposure feature can be used with the auto gain at the same time, when target grey is changed from dark to bright, the auto exposure adjust is prior to auto gain adjust. Vice versa, when target grey is changed from bright to dark, the auto gain adjust is prior to auto exposure adjust.

#### 8.3.5. Auto White Balance

##### 8.3.5.1. Auto White Balance ROI

Auto White Balance feature use the image data from AWBROI to calculate the white balance ratio, and then the white balance ratio is used to adjust the components of the image.

ROI is defined in the following way:

AWBROIOffsetX: The offset of the X axis direction.

AWBROIOffsetY: The offset of the Y axis direction.

AWBROIWidth: The width of ROI.

AWBROIHeight: The height of ROI.

Offset is the offset value that relative to the upper left corner of the image. Where the step of AWBROIOffsetX and AWBROIWidth is 4, the step of AWBROIOffsetY and AWBROIHeight is 2. The ROI setting depends on the current image and cannot exceed the current image range. Assuming the current

image width is Width, the image height is Height, then the ROI setting need to meet the following condition 2:

$$AWBROIWidth + AWBROIOffsetX \leq Width$$

$$AWBROIHeight + AWBROIOffsetY \leq Height$$

If condition 2 is not met, the user cannot set the ROI.

The default value of ROI is the entire image, you can set the "white dot" area (ROI) according to your need. Where the minimum value of AWBROIWidth can be set is 16, the maximum value is equal to the current image width. The minimum value of AWBROIHeight can be set is 16, the maximum value is equal to the current image height, they are all need to meet the condition 2.

Assuming the current image width is 1024, the height is 1000, and then the "white dot" area ROI setting is:

$$AWBROIOffsetX = 100$$

$$AWBROIOffsetY = 50$$

$$AWBROIWidth = 640$$

$$AWBROIHeight = 480$$

The relative position of the ROI and the image is shown in Figure 8-27.

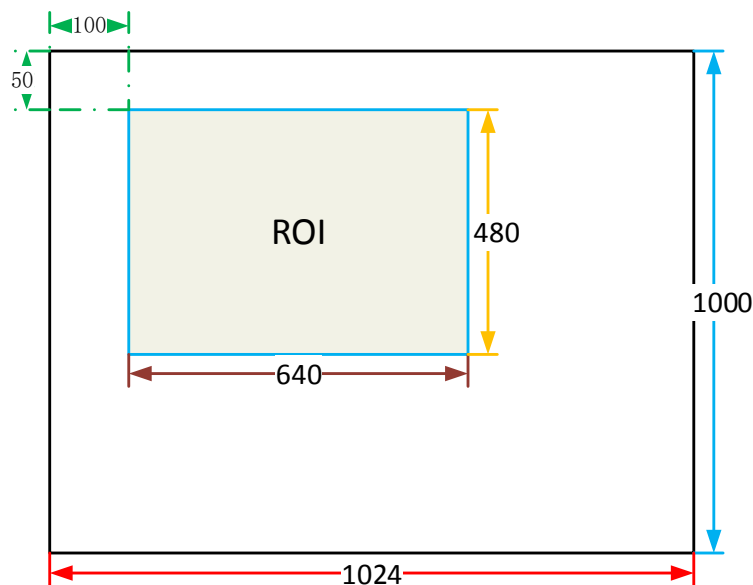

Figure 8-27 An example for the relative position between the ROI and the current image

### 8.3.5.2. Auto White Balance Adjustment

The auto white balance can be set to "Once" or "Continuous" mode. When using the "Once" mode, the camera just adjusts the white balance ratio once, when using the "Continuous" mode, the camera continuously adjusts the white balance ratio based on the data in AWBROI.

The auto white balance feature can also select the color temperature. When the color temperature of the selection is "Adaptive", the data in ROI always adjusting the red, green and blue to the same. When selecting the specific color temperature, the camera adjusts the factor according to the light source, so



that the hue of the ROI is the same as the hue of the light source. That is: high temperature is cold, low color temperature is warm.

The auto white balance feature is only available on color sensors.

### 8.3.6. Test Pattern

The MER-U3 series camera supports three test images: gray gradient test image, static diagonal gray gradient test image, and moving diagonal gray gradient test image. When the camera captures in RAW10 mode, the gray value of test image is: the pixel gray value in RAW8 mode multiplies by 4, as the output of pixel gray value in RAW10 mode.

The following three test images are illustrated in the RAW8 mode.

- **GrayFrameRampMoving**

In the gray gradient test image, all the pixels' gray values are the same in the frame. In the adjacent frame, the gray value of the next frame increases by 1 compared to the previous frame, until to 255, and then the next frame gray value returns to 0, and so on. A printscreen of a single frame is shown in Figure 8-28.



Figure 8-28 Gray gradient test image

- **SlantLineMoving**

In the moving diagonal gray gradient test image, the first pixel value of adjacent row in each frame increases by 1, until the last row. When the pixel gray value increases to 255, the next pixel gray value returns to 0. The first pixel gray value of adjacent column increases by 1, until the last column. When the pixel gray value increases to 255, the next pixel gray value returns to 0.

In the moving diagonal gray gradient test image, in the adjacent frame, the first pixel gray value of the next frame increases by 1 compared to the previous frame. So, in the dynamic image, the image is scrolling to the left. A printscreen of the moving diagonal gray gradient test image is shown in Figure 8-29:

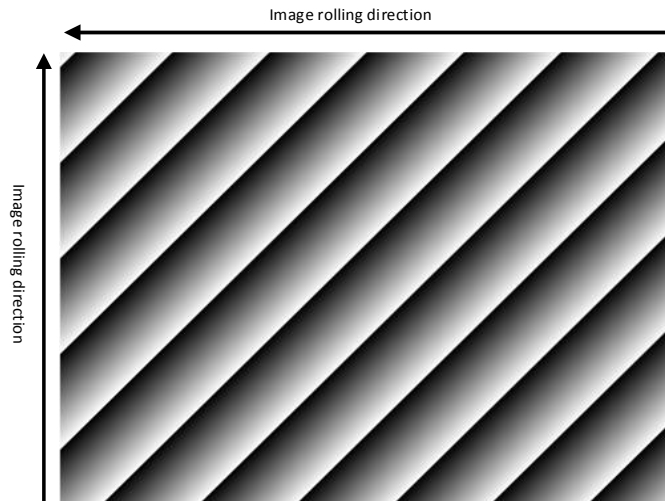

Figure 8-29 Moving diagonal gray gradient test image

● **SlantLine**

In the static diagonal gray gradient test image, the first pixel gray value is 0, the first pixel gray value of adjacent row increases by 1, until the last row. When the pixel gray value increases to 255, the next pixel gray value returns to 0. The first pixel gray value of adjacent column increases by 1, until the last column. When the pixel gray value increases to 255, the next pixel gray value returns to 0.

Compared to the moving diagonal gray gradient test image, in the adjacent image of the static diagonal gray gradient test image, the gray value in the same position remains unchanged. A printscreen of the static diagonal gray gradient test image is shown in Figure 8-30.



Figure 8-30 Static diagonal gray gradient test image

8.3.7. User Set Control

By setting various parameters of the camera, the camera can perform the best performance in different environments. There are two ways to set parameters: one is to modify the parameters manually, and the other is to load parameter set. In order to save the specific parameters of the users, avoiding to set the parameters every time when you open the camera, the MER-U3 series camera provides a function to save the parameter set, which can easily save the parameters that the user use, including the control parameters that the camera needed. There three types of configuration parameters: the currently effective

configuration parameters, the vendor default configuration parameters (Default), and the user configuration parameters (UserSet).

Three operations can be performed on the configuration parameters, including save parameters (UserSetSave), load parameters (UserSetLoad), and set the startup parameter set (UserSetDefault). The UserSetSave is to save the effective configuration parameters to the user configuration parameter set which is set by the user. The UserSetLoad is to load the vendor default configuration parameters (Default) or the user configuration parameters (UserSet) to the current effective configuration parameters. The UserSetDefault is refer to the user can specify a set of parameters which to be loaded into the effective configuration parameters automatically when the camera is reset or powered on. And the camera can work under this set of parameters. This set of parameters can be vendor default configuration parameters or user configuration parameters.

### 1) The type of configuration parameters

The type of configuration parameters includes: the current effective configuration parameters, vendor default configuration parameters, user configuration parameters.

The current effective configuration parameters: Refers to the current control parameters used by the camera. Using API function or Demo program to modify the current control parameters of the camera is to modify the effective configuration parameters. The effective parameters are stored in volatile memory of the camera, so when the camera is reset or powered on again, the effective configuration parameters will be lost.

The vendor default configuration parameters (Default): Before the camera leaves the factory, the camera manufacturer will test the camera to assess the camera's performance and optimize the configuration parameters of the camera. The vendor default configuration parameters are the camera configuration parameters optimized by the vendor in a particular environment, these parameters are stored in the non-volatile memory of the camera, so when the camera is reset or powered on again, the effective configuration parameters will not be lost, and these parameters cannot be modified.

The user configuration parameters (UserSet): The effective parameters are stored in volatile memory of the camera, so when the camera is reset or powered on again, the effective configuration parameters will be lost. You can store the effective configuration parameters to the user configuration parameters, the user configuration parameters are stored in the non-volatile memory of the camera, so when the camera is reset or powered on again, the user configuration parameters will not be lost. The MER-U3 series camera can store a set of user configuration parameters.

### 2) The operation of configuration parameters

The operations for configuration parameters include the following three types: save parameters, load parameters and set the UserSetDefault.

**Save parameters (UserSetSave):** Save the current effective configuration parameters to the user configuration parameters. The storage steps are as follows:

- 1) Modify the camera's configuration parameters, until the camera runs to the user's requirements.
- 2) Use UserSetSelector to select UserSet0. Execute UserSetSave command.

The camera's configuration parameters which are saved in the user parameter set include:

- DeviceLinkThroughputLimitMode, DeviceLinkThroughputLimit
- OffsetX, OffsetY, Width, Height
- PixelFormat
- TestPattern
- TriggerMode, TriggerSource, TriggerPolarity, TriggerDelay
- TriggerFilterRisingEdge, TriggerFilterFallingEdge
- ExposureTime
- ExposureAuto, AutoExposureTimeMax, AutoExposureTimeMin
- AAROIOffsetX, AAROIOffsetY, AAROIWidth, AAROIHeight
- ExpectedGrayValue
- LineMode, LineInverter, LineSource, UserOutputValue
- Gain
- GainAuto, AutoGainMax,AutoGainMin
- BalanceRatio
- BalanceWhiteAuto, AWBLampHouse
- AWBROIOffsetX, AWBROIOffsetY, AWBROIWidth, AWBROIHeight
- DeadPixelCorrect
- ChunkModeActive, ChunkEnable

**Load parameters (UserSetLoad):** Load the vendor default configuration parameters or the user configuration parameters into the effective configuration parameters. After this operation is performed, the effective configuration parameters will be covered by the loaded parameters which are selected by the user, and the new effective configuration parameters are generated. The operation steps are as follows:

- 1) Use UserSetSelector to select Default or UserSet0.
- 2) Execute UserSetLoad command to load the UserSet specified by UserSetSelector to the device and makes it active.

**Change startup parameter set (UserSetDefault):** The user can use UserSetDefault to select Default or UserSet0 as the UserSetDefault. When the camera is reset or powered on again, the parameters in the UserSetDefault will be loaded into the effective configuration parameters.

### 8.3.8. Device User ID

The MER-U3 series camera provides programmable device user ID function, the user can set a unique identification for the camera, and can open and control the camera by the unique identification.

The user-defined name is a string which maximum length is 64 bytes, the user can set it by the following ways:

- 1) Set by the GalxyView, as shown in the Figure 8-31.

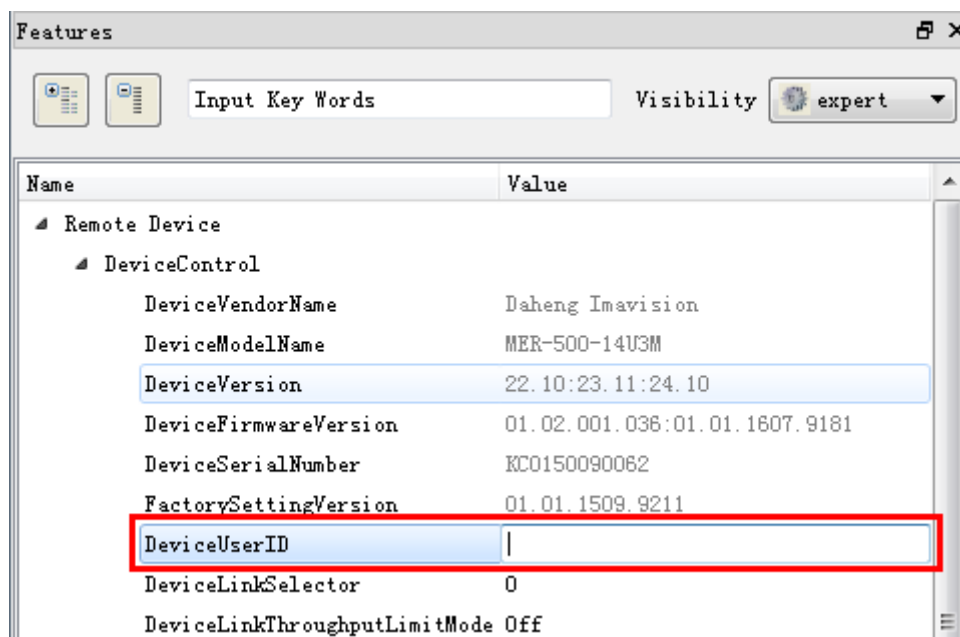

Figure 8-31 DeviceUserID

- 2) Set by calling the software interface, for details please see the Programmer's Guide.



When using multi-cameras at the same time, it is necessary to ensure the uniqueness of the user-defined name of each camera, otherwise, an exception will occur when the camera is opened.

### 8.3.9. Timestamp

The timestamp feature counts the number of ticks generated by the camera's internal device clock. As soon as the camera is powered on, it starts generating and counting clock ticks. The counter is reset to 0 whenever the camera is powered off and on again. Some of the camera's features use timestamp values, such as frame information, and timestamps can be used to test the time spent on some of the camera's operations.

The unit of timestamp is ns.

### 8.3.10. Binning

The feature of Binning is to combine multiple pixels adjacent to each other in the sensor into a single value, and process the average value of multiple pixels or sum the multiple pixel values, which may increase the signal-to-noise ratio or the camera's response to light.

● **How Binning Works**

On color cameras, the camera combines (sums or averages) the pixel values of adjacent pixels of the same color:

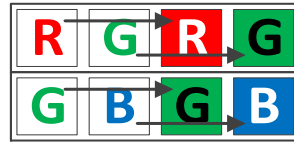

Figure 8-32 Horizontal color Binning by 2



Figure 8-33 Vertical color Binning by 2

When the horizontal Binning factor and the vertical Binning factor are both set to 2, the camera combines the adjacent 4 sub-pixels of the same color according to the corresponding positions, and outputs the combined pixel values as one sub-pixel.

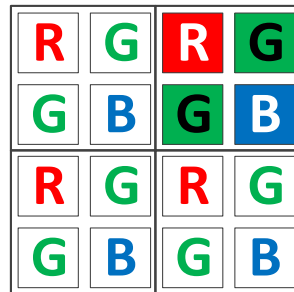

Figure 8-34 Horizontal and vertical color Binning by 2x2

On monochrome cameras, the camera combines (sums or averages) the pixel values of directly adjacent pixels:

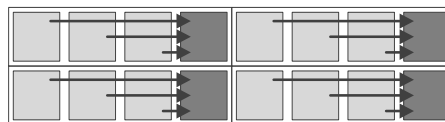

Figure 8-35 Horizontal mono Binning by 4

● **Binning Factors**

Two types of Binning are available: horizontal Binning and vertical Binning. You can set the Binning factor in one or two directions.

Horizontal Binning is the processing of pixels in adjacent rows.

Vertical Binning is the processing of pixels in adjacent columns.

Binning factor 1: Disable Binning.

Binning factor 2, 4: Indicate the number of rows or columns to be processed.

For example, the horizontal Binning factor 2 indicates that the Binning is enabled in the horizontal direction, and the pixels of two adjacent rows are processed.

### ● Binning Modes

The Binning mode defines how pixels are combined when Binning is enabled. Two types of the Binning mode are available: Sum and Average.

**Sum:** The values of the affected pixels are summed and then output as one pixel. This improves the signal-to-noise ratio, but also increases the camera's response to light.

**Average:** The values of the affected pixels are averaged. This greatly improves the signal-to-noise ratio without affecting the camera's response to light.

### ● Considerations when Using Binning

#### 1) Effect on ROI settings

When Binning is used, the value of the current ROI of the image, the maximum ROI of the image, the auto function ROI, and the auto white balance ROI will change. The changed value is the original value (the value before the setting) divided by the Binning factor.

For example, assume that you are using a camera with a 1200 x 960 sensor. Horizontal Binning by 2 and vertical Binning by 2 are enabled. In this case, the maximum ROI width is 600 and the maximum ROI height is 480.

#### 2) Increased response to light

Using Binning with the Binning mode set to **Sum** can significantly increase the camera's response to light. When pixel values are summed, the acquired images may look overexposed. If this is the case, you can reduce the lens aperture, the intensity of your illumination, the camera's exposure time setting, or the camera's gain setting.

#### 3) Possible image distortion

Objects will only appear undistorted in the image if the numbers of binned rows and columns are equal. With all other combinations, objects will appear distorted. For example, if you combine vertical Binning by 2 with horizontal Binning by 4, the target objects will appear squashed.

#### 4) Mutually exclusive with Decimation

Binning and Decimation cannot be used simultaneously in the same direction. When the horizontal Binning value is set to a value other than 1, the horizontal Decimation feature cannot be used. When the vertical Binning value is set to a value other than 1, the vertical Decimation feature cannot be used.

Camera models that support this feature:

Model
MER-301-125U3M/C(-L)
MER-302-56U3M/C(-L)

### 8.3.11. Decimation

The Decimation can reduce the number of sensor pixel columns or rows that are transmitted by the camera, reducing the amount of data that needs to be transmitted and reducing bandwidth usage.

- **How Vertical Decimation Works**

On mono cameras, if you specify a vertical Decimation factor of  $n$ , the camera transmits only every  $n^{\text{th}}$  row. For example, when you specify a vertical Decimation factor of 2, the camera skips row 1, transmits row 2, skips row 3, and so on.

On color cameras, if you specify a vertical Decimation factor of  $n$ , the camera transmits only every  $n^{\text{th}}$  pair of rows. For example, when you specify a vertical Decimation factor of 2, the camera skips rows 1 and 2, transmits rows 3 and 4, skips rows 5 and 6, and so on.

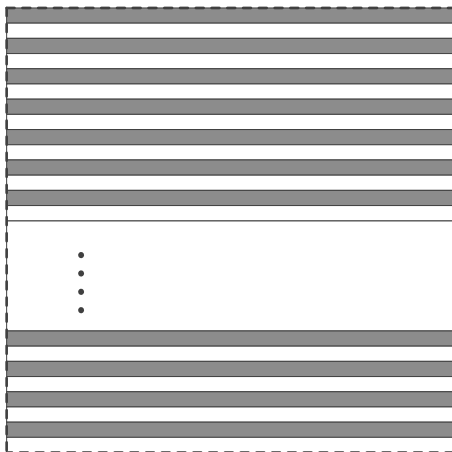

Figure 8-36 Mono camera vertical Decimation

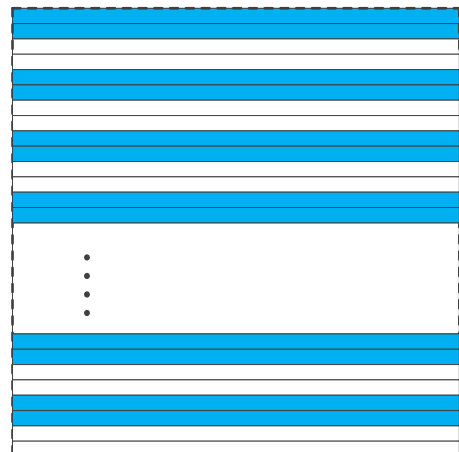

Figure 8-37 Color camera vertical Decimation

As a result, the image height is reduced. For example, enabling vertical Decimation by 2 halves the image height. The camera automatically adjusts the image ROI settings.

Vertical Decimation significantly increases the camera's frame rate. For details, please refer to the [MER-U3 Frame Rate Calculation Tool](#).

- **How Horizontal Decimation Works**

On mono cameras, if you specify a horizontal Decimation factor of  $n$ , the camera transmits only every  $n^{\text{th}}$  column. For example, if specify set a horizontal Decimation factor of 2, the camera skips column 1, transmits column 2, skips column 3, and so on.



On color cameras, if you specify a horizontal Decimation factor of  $n$ , the camera transmits only every  $n^{\text{th}}$  pair of columns. For example, if you specify a horizontal Decimation factor of 2, the camera skips columns 1 and 2, transmits columns 3 and 4, skips columns 5 and 6, and so on.

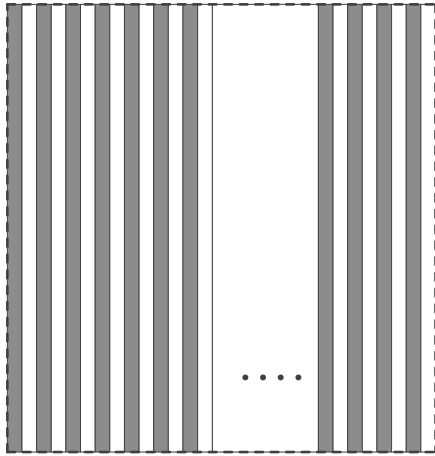

Figure 8-38 Mono camera horizontal Decimation

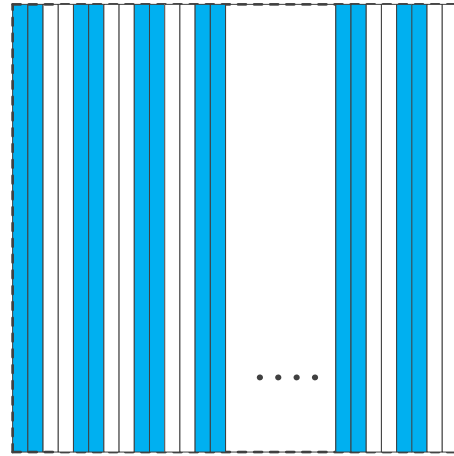

Figure 8-39 Color camera horizontal Decimation

As a result, the image width is reduced. For example, enabling horizontal Decimation by 2 halves the image width. The camera automatically adjusts the image ROI settings.

Horizontal Decimation does not (or only to a very small extent) increase the camera's frame rate.

### ● Configuring Decimation

To configure vertical Decimation, enter a value for the DecimationVertical parameter. To configure horizontal Decimation, enter a value for the DecimationHorizontal parameter.

The value of the parameters defines the Decimation factor. Depending on your camera model, the following values are available:

- 1: Disable Decimation.
- 2: Enable Decimation.

### ● Considerations When Using Decimation

#### 1) Effect on ROI settings

When you are using Decimation, the settings for your image ROI refer to the resulting number of rows and columns. Taking MER-502-79U3M/C(-L) as an example, the camera's default resolution is 2448×2048. When horizontal Decimation by 4 and vertical Decimation by 4 are enabled, the maximum ROI width would be 612, and the maximum ROI height would be 512.

#### 2) Reduced resolution

Using Decimation effectively reduces the resolution of the camera's imaging sensor. Taking MER-502-79U3M/C(-L) as an example, the camera's default resolution is 2448×2048. When horizontal Decimation by 4 and vertical Decimation by 4 are enabled, the effective resolution of the sensor is reduced to 612×512.

#### 3) Possible image distortion

The displayed image will not be distorted if the vertical and horizontal Decimation factors are equal. When only horizontal Decimation or vertical Decimation is used, the displayed image will be reduced in width or height.

4) Mutually exclusive with Binning

Decimation and Binning cannot be used simultaneously in the same direction. When the horizontal Decimation value is set to a value other than 1, the horizontal Binning feature cannot be used. When the vertical Decimation value is set to a value other than 1, the vertical Binning feature cannot be used.

Camera models that support this feature:

Model
MER-031-860U3M/C(-L)
MER-031-860U3M(-L)NIR
MER-050-560U3M/C(-L)
MER-050-560U3M(-L) NIR
MER-131-210U3M/C(-L)
MER-131-210U3M(-L) NIR

8.3.12. Reverse X and Reverse Y

The Reverse X and Reverse Y features can mirror acquired images horizontally, vertically, or both.

● Enabling Reverse X

To enable Reverse X, set the **ReverseX** parameter to **true**. The camera mirrors the image horizontally.



Figure 8-40 The original image



Figure 8-41 Reverse X enabled

● Enabling Reverse Y

To enable Reverse Y, set the **ReverseY** parameter to **true**. The camera mirrors the image vertically.



Figure 8-42 The original image

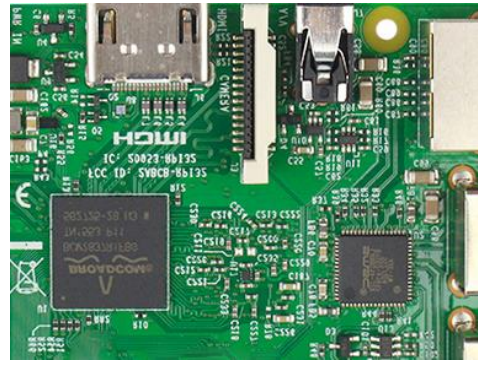

Figure 8-43 Reverse Y enabled

- **Enabling Reverse X and Y**

To enable Reverse X and Y, set the **ReverseX** and **ReverseY** parameters to **true**. The camera mirrors the image horizontally and vertically.



Figure 8-44 The original image

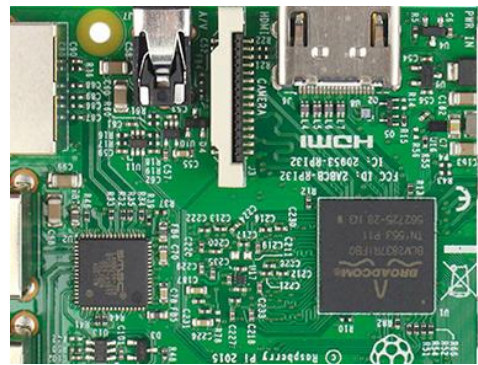

Figure 8-45 Reverse X and Y enabled

- **Using Image ROI with Reverse X or Reverse Y**

If you have specified an image ROI while using Reverse X or Reverse Y, you must bear in mind that the position of the ROI relative to the sensor remains the same. Therefore, the camera acquires different portions of the image depending on whether the Reverse X or the Reverse Y feature are enabled:



Figure 8-46 The original image



Figure 8-47 Reverse X enabled

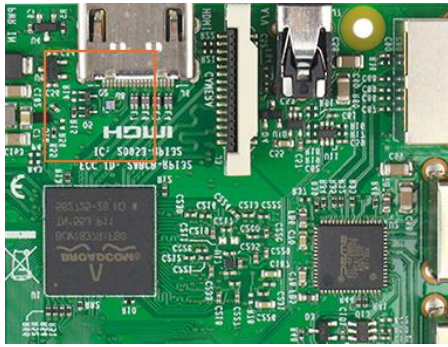

Figure 8-48 Reverse Y enabled

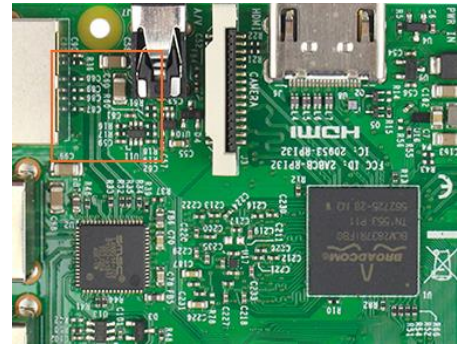

Figure 8-49 Reverse X and Y enabled

● **Pixel Format Alignment**

The alignment of the Bayer format does not change when the camera is using the reverse feature.

Camera models that support this feature:

Model
MER-031-860U3M(-L)
MER-031-860U3M(-L)NIR
MER-041-436U3M/C(-L)
MER-131-210U3M(-L)
MER-131-210U3M(-L) NIR
MER-230-168U3M(-L)

8.3.13. User Data Area

The user data area is a FLASH data area reserved for the user, and the user can use the area to save algorithm factors, parameter configurations, etc.

The user data area is 16K bytes and is divided into 4 data segments, each of which is 4K bytes. The user can access the user data area through the API interface. The data is saved to the camera flash area immediately after being written, and the data will not disappear after the camera is powered off.

Camera models that support this feature:

Model
MER-500-14U3M/C(-L)

8.3.14. Timer

The camera only supports one timer (Timer1), which can be started by a specified event or signal (only ExposureStart signal is supported). The Timer can configure a timer output signal that goes high on a specific event or signal and goes low after a specific duration. And the timer is cleared when the output signal goes low. A schematic diagram of the timer working process is as follows:

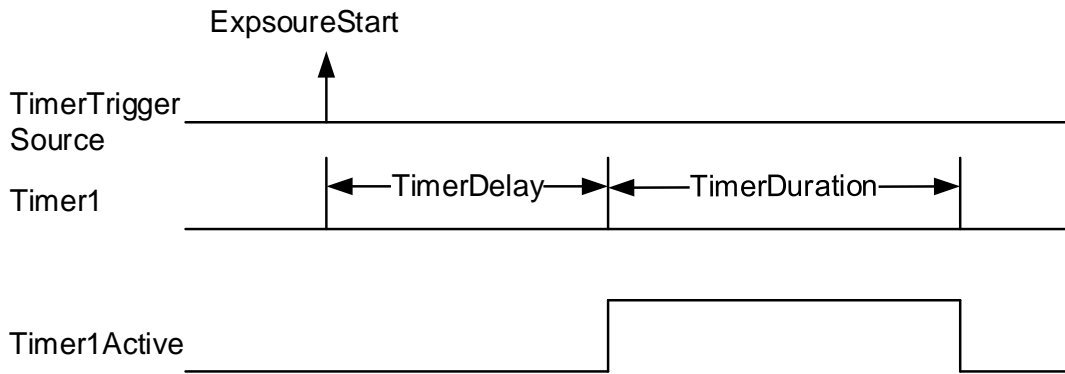

Figure 8-50 Timer1Active schematic diagram

The timer configuration process is as follows:

1. Set TimerSelector, currently only Timer1 supported.
  2. Set LineSelector.
  3. Set the LineSource to Timer1Active.
  4. Set TimerTriggerSource, currently only ExposureStart supported.
  5. Set TimerDelay, the range of TimerDelay is [0, 16777215], the unit is  $\mu\text{s}$ .
  6. Set TimerDuration, the range of TimerDuration is [0, 16777215], the unit is  $\mu\text{s}$ .
- 1) From the start of the timer to the full output of Timer1Active, this process will not be interrupted by the ExposureStart signal, and Timer1Active must be completely output to start timing according to the next ExposureStart signal. As shown in the figure below, the red ExposureStart signals are ignored.

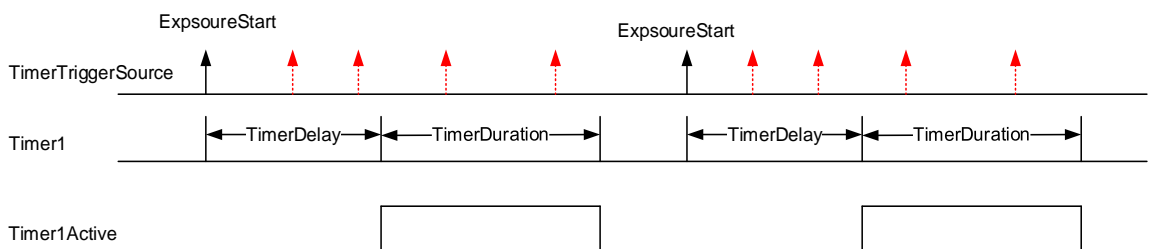

Figure 8-51 The relationship of Timer1Active and ExposureStart signal

- 2) After the acquisition is stopped, the timer is immediately cleared and the Timer1Active signal goes low immediately.

Camera models that support this feature:

Model
MER-302-56U3M/C(-L)

### 8.3.15. Counter

The camera only supports one counter (Counter1), which can count the number of FrameTrigger, AcquisitionTrigger and FrameStart signals received by the camera. The counter starts counting from 0. You can select one of the above three signals to count by CounterEventSource. The FrameTrigger and AcquisitionTrigger signals of the counter statistics refer to the signals that have been triggered for filtering without a trigger delay.

If CounterValue is enabled, the statistical data can be inserted into the frame information and output with the image.

The counter can be reset by an external signal. The reset source is selected by CounterResetSource. Currently, the CounterResetSource option supports Off, SoftWare, Line0, Line2, and Line3. Among them, Off means no reset, SoftWare means software reset, Line0, Line2 or Line3 means reset through IO port input signal. The polarity of the reset signal only supports RisingEdge, which means reset the Counter on the rising edge of the reset signal.

Counter configuration:

1. Set CounterSelector, currently only Counter1 supported.
2. Set CounterEventSource, the values that can be set are FrameStart, FrameTrigger, AcquisitionTrigger.
3. Set CounterResetSource, the values that can be set are Off, SoftWare, Line0, Line2, Line3.
4. Set CounterResetActivation, currently only RisingEdge supported.



- 1) After the acquisition is stopped, the Counter continues to work, will not be cleared, and it will be cleared when the camera is powered off.
- 2) CounterReset is used to software reset the counter.

Camera models that support this feature:

Model
MER-302-56U3M/C(-L)

## 8.4. Image Processing

### 8.4.1. Defect Pixel Correction

Due to the technical defects of the image sensor, the camera has defect pixels. Some of these defect pixels are fixed at the same gray value and do not change with the scene, which are called dead pixels. In acquired images, some pixels may appear significantly brighter or darker than the rest, even if uniform light is used, resulting in a significant difference between the gray value and the surrounding pixels, which is called dark pixels or bright pixels.

The defect pixel correction feature minimizes the influence of these sensitivity differences. The camera identifies pixels that have a significantly higher or lower intensity value than their neighboring pixels ("outlier pixels") and adjusts their intensity value.

Camera models that support this feature:

Model
MER-051-120U3M/C(-L)
MER-131-210U3M/C(-L)
MER-500-14U3M/C(-L)
MER-1070-14U3M/C(-L)
MER-1520-13U3C
MER-1520-13U3C-L
MER-1810-21U3C
MER-1810-21U3C-L

## 8.5. Image Transmission

### 8.5.1. Calculate Frame Rate

#### 1) Frame Period

You can calculate the frame period of the MER-U3 series camera by the following formula:

$$T_f = \text{Max}\left(\frac{\text{ImageSize} * 10^6}{\text{BandWidth}_{\text{USB}}}, \frac{\text{ImageSize} * 10^6}{\text{DeviceLinkThroughputLimit}}, T_{\text{acq}}, T_{\text{exp}}\right)$$

Among them:

$$\text{ImageSize} = \text{Width} * \text{Height} * \text{PixelSize} + 84$$

$T_f$ : The camera's frame period, unit:  $\mu\text{s}$ .

Width: The current image width.

Height: The current image height.

PixelSize: The size of the pixel, in 8bit mode, the value is 1, and in 10bit/12bit mode, the value is 2.

$\text{BandWidth}_{\text{USB}}$ : The bandwidth of the USB interface, unit: Bps, for details please see [section 8.5.2](#).

$\text{DeviceLinkThroughputLimit}$ : The limit of the device link throughput bandwidth, unit: Bps, for details please see [section 8.5.3](#).

$T_{\text{acq}}$ : The acquisition time of the camera, unit:  $\mu\text{s}$ , for details please see [section 8.5.4](#).

$T_{\text{exp}}$ : The exposure time of the camera, unit:  $\mu\text{s}$ .

#### 2) Frame rate (Unit: fps)

$$F = \frac{10^6}{T_f}$$



It is recommended to use the frame rate calculation tool, the frame rate will be calculated automatically after the configuration parameters are filled.

### 8.5.2. USB Interface Bandwidth

The theoretical bandwidth of the USB interface of MER-U3 series camera is 400MBps, but actually the value will decrease with the type of the USB3.0 host controller, the version of the host controller driver, the wastage of the HUB and the host performance. The user can refer the test result of the interface bandwidth in <TN-USB3.0 host controller bandwidth and CPU utilization> document.

### 8.5.3. DeviceLinkThroughputLimit

The MER-U3 series camera provides bandwidth limit function, in order to control the upper limit bandwidth of single device. When the DeviceLinkThroughputLimit is greater than the current device acquisition bandwidth, the current device acquisition bandwidth will not change, when the DeviceLinkThroughputLimit is less than the current device acquisition bandwidth, the current device acquisition bandwidth will be reduced to the limit of the DeviceLinkThroughputLimit, the current device acquisition bandwidth can be read from the camera.

When the camera is working in trigger mode, the bandwidth limit will restrict the maximum trigger frequency.

Example 1:

The MER-500-14U3M/C(-L) is working in continuous mode, the DeviceLinkCurrentThroughput is 35000000Bps, the DeviceLinkThroughputLimit is 40000000Bps, and then the DeviceLinkCurrentThroughput is still 35000000Bps. If the DeviceLinkCurrentThroughput is 70000000Bps, the DeviceLinkThroughputLimit is 40000000Bps, and then the DeviceLinkCurrentThroughput will be 40000000Bps.

Example 2:

The MER-500-14U3M/C(-L) is working in trigger mode, the DeviceLinkCurrentThroughput is 400000000Bps, the maximum trigger frequency is 14Hz @ full resolution (8bit), when the DeviceLinkCurrentThroughput is 35000000Bps, the maximum trigger frequency is 7Hz @ full resolution (8bit).

Model	Min. of DeviceLink ThroughputLimit	Max. of DeviceLink ThroughputLimit	Step of DeviceLinkThroughputLimit
MER-031-860U3M/C(-L)	35000000Bps (8bit)	400000000 Bps	1000000Bps
	70000000Bps (10bit)		
MER-031-860U3M(-L) NIR	35000000Bps (8bit)	400000000 Bps	1000000Bps
	70000000Bps (10bit)		
MER-041-436U3M/C(-L)	35000000Bps (8bit)	400000000 Bps	1000000Bps



	70000000Bps (10bit)		
MER-050-560U3M/C(-L)	35000000Bps (8bit)	400000000 Bps	1000000Bps
	70000000Bps (10bit)		
MER-050-560U3M(-L) NIR	35000000Bps (8bit)	400000000 Bps	1000000Bps
	70000000Bps (10bit)		
MER-051-120U3M/C(-L)	35000000Bps (8bit)	400000000 Bps	1000000Bps
	70000000Bps (10bit)		
MER-131-210U3M/C(-L)	35000000Bps (8bit)	400000000 Bps	1000000Bps
	70000000Bps (10bit)		
MER-131-210U3M(-L) NIR	35000000Bps (8bit)	400000000 Bps	1000000Bps
	70000000Bps (10bit)		
MER-132-43U3M/C(-L)	35000000Bps (8bit)	400000000 Bps	1000000Bps
	70000000Bps (12bit)		
MER-131-210U3M/C(-L)	35000000Bps (8bit)	400000000 Bps	1000000Bps
	70000000Bps (10bit)		
MER-134-93U3M/C(-L)	35000000Bps (8bit)	400000000 Bps	1000000Bps
	70000000Bps (10bit)		
MER-160-227U3M/C(-L)	35000000Bps (8bit)	400000000 Bps	1000000Bps
	70000000Bps (10bit)		
MER-230-168U3M/C(-L)	35000000Bps (8bit)	400000000 Bps	1000000Bps
	70000000Bps (10bit)		
MER-231-41U3M/C(-L)	35000000Bps (8bit)	400000000 Bps	1000000Bps
	70000000Bps (10bit)		
MER-301-125U3M/C(-L)	35000000Bps (8bit)	400000000 Bps	1000000Bps
	70000000Bps (10bit)		
MER-302-56U3M/C(-L)	35000000Bps (8bit)	400000000 Bps	1000000Bps
	70000000Bps (10bit)		
MER-500-14U3M/C(-L)	35000000Bps (8bit)	400000000 Bps	1000000Bps
	70000000Bps (10bit)		

MER-502-79U3M/C(-L)	35000000Bps (8bit)	400000000 Bps	1000000Bps
	70000000Bps (10bit)		
MER-502-79U3M(-L) POL	35000000Bps (8bit)	400000000 Bps	1000000Bps
	70000000Bps (10bit)		
MER-503-36U3M/C(-L)	35000000Bps (8bit)	400000000 Bps	1000000Bps
	70000000Bps (10bit)		
MER-630-60U3M/C(-L)	35000000Bps (8bit)	400000000 Bps	1000000Bps
	70000000Bps (10bit)		
MER-1070-14U3M/C(-L)	35000000Bps (8bit)	400000000 Bps	1000000Bps
	70000000Bps (12bit)		
MER-1220-32U3M/C(-L)	35000000Bps (8bit)	400000000 Bps	1000000Bps
	70000000Bps (12bit)		
MER-1520-13U3C(-L)	35000000Bps (8bit)	400000000 Bps	1000000Bps
	70000000Bps (12bit)		
MER-1810-21U3C(-L)	35000000Bps (8bit)	400000000 Bps	1000000Bps
	70000000Bps (12bit)		
MER-2000-19U3M/C(-L)	35000000Bps (8bit)	400000000 Bps	1000000Bps
	70000000Bps (12bit)		

Table 8-9 MER-U3 camera bandwidth control



When setting the DeviceLinkThroughputLimitMode or change the DeviceLinkThroughputLimit, some devices need to be stopped acquisition. The models are as follows:

Model	Support setting device's bandwidth limit when acquiring images?
MER-031-860U3M/C(-L)/MER-031-860U3M(-L) NIR MER-050-560U3M/C(-L)/MER-050-560U3M NIR MER-131-210U3M/C(-L)/MER-131-210U3M/C(-L) NIR MER-132-43U3M/C(-L)/MER-230-168U3M/C(-L) MER-231-41U3M/C(-L)/MER-500-14U3M/C(-L) MER-1070-14U3M/C(-L)/MER-1520-13U3C(-L)	No
The other models of MER-U3 series camera	Yes

Table 8-10 The models which support setting device 's bandwidth control function when acquiring images

### 8.5.4. Camera Acquisition Time

The acquisition time of the camera is related to the horizontal offset, vertical offset, width, and height of the image ROI.

The formulas are as follows:

1) For MER-031-860U3M/C(-L)/MER-031-860U3M NIR camera:

Row period (unit:  $\mu\text{s}$ )

$$T_{\text{row}} = 13889 * \max\left(\left(\frac{\text{Width}}{4} + 4\right), 84\right) * 10^{-6}$$

The acquisition time (unit:  $\mu\text{s}$ )

$$T_{\text{acq}} = (\text{Height}) * T_{\text{row}} + 85.5$$

2) For MER-041-436U3M/C(-L) camera:

Row period (unit:  $\mu\text{s}$ )

$$T_{\text{row}} = \frac{147}{37.5} = 3.92$$

The acquisition time (unit:  $\mu\text{s}$ )

$$T_{\text{acq}} = (\text{Height} + 32) * T_{\text{row}}$$

3) For MER-050-560U3M/C(-L) /MER-050-560U3M(-L) NIR camera:

Row period (unit:  $\mu\text{s}$ )

$$T_{\text{row}} = 13889 * \max\left(\left(\frac{\text{Width}}{4} + 4\right), 84\right) * 10^{-6}$$

The acquisition time (unit:  $\mu\text{s}$ )

$$T_{\text{acq}} = (\text{Height}) * T_{\text{row}} + 19.8$$

4) For MER-051-120U3M/C(-L) camera:

Row period (unit:  $\mu\text{s}$ )

$$T_{\text{row}} = 14706 * (74 + \text{Width}) * 10^{-6}$$

The acquisition time (unit:  $\mu\text{s}$ )

$$T_{\text{acq}} = (\text{Height}) * T_{\text{row}} + 78.2$$

5) For MER-131-210U3M/C(-L)/MER-131-210U3M(-L) NIR camera:

Row period (unit:  $\mu\text{s}$ )

$$T_{\text{row}} = 14705 * \max \left( \left( \frac{\text{Width}}{4} + 4 \right), 84 \right) * 10^{-6}$$

The acquisition time (unit:  $\mu\text{s}$ )

$$T_{\text{acq}} = (\text{Height}) * T_{\text{row}} + 11.4$$

6) For MER-132-43U3M/C(-L) camera:

Row period (unit:  $\mu\text{s}$ )

$$T_{\text{row}} = 1532 * 15.384 * 10^{-3} \approx 23.569$$

The acquisition time (unit:  $\mu\text{s}$ )

$$T_{\text{acq}} = \left( \text{int} \left( \frac{996 - (\text{height} + \text{offsety} + 16)}{8} \right) + \text{int} \left( \frac{\text{offsety} + 16}{8} \right) + (\text{offsety} + 16) \right) - \left( \left( \text{int} \left( \frac{\text{offsety} + 16}{8} \right) - 1 \right) * 8 \right) + \text{Height} + 1 \right) * T_{\text{row}}$$

7) For MER-131-210U3M/C(-L) camera:

In continuous mode, the row period (unit:  $\mu\text{s}$ )

$$T_{\text{row}} = \frac{1388}{74.25} = 18.69$$

In trigger mode, the row period (unit:  $\mu\text{s}$ )

$$T_{\text{row}} = \frac{1650}{74.25} = 22.222$$

The acquisition time (unit:  $\mu\text{s}$ )

$$T_{\text{acq}} = (\text{Height} + 30) * T_{\text{row}}$$

8) For MER-134-93U3M/C(-L) camera:

Row period (unit:  $\mu\text{s}$ )

$$T_{\text{row}} = \frac{86 + \frac{\text{Width}}{2} + 10}{72}$$

The acquisition time (unit:  $\mu\text{s}$ )

$$T_{\text{acq}} = \text{Height} * T_{\text{row}} + 149.5$$

When using a single ROI, the width and height represent the image width and image height of the Region0, when using multi-ROI, the width and height represent the equivalent width and equivalent height which are calculated by the Region0, Region1, Region2, and Region3. The specific calculate method can see [section 8.2.2](#).

9) For MER-160-227U3M/C(-L) camera:

When the pixel format is Mono8 or BayerRG8, the row period (unit:  $\mu\text{s}$ )

$$T_{\text{row}} = \frac{147}{37.5} = 3.92$$

When the pixel format is Mono10 or BayerRG10, the row period (unit:  $\mu\text{s}$ )

$$T_{\text{row}} = \frac{147 * 2}{37.5} = 7.84$$

The acquisition time (unit:  $\mu\text{s}$ )

$$T_{\text{acq}} = (\text{Height} + 32) * T_{\text{row}}$$

10) For MER-230-168U3M/C(-L) camera:

When the pixel format is Mono8 or BayerRG8, the row period (unit:  $\mu\text{s}$ )

$$T_{\text{row}} = \frac{180}{37.5} = 4.8$$

When the pixel format is Mono10 or BayerRG10, the row period (unit:  $\mu\text{s}$ )

$$T_{\text{row}} = \frac{360}{37.5} = 9.6$$

The acquisition time (unit:  $\mu\text{s}$ )

$$T_{\text{acq}} = (\text{Height} + 38) * T_{\text{row}}$$

11) For MER-231-41U3M/C(-L) camera:

Row period (unit:  $\mu\text{s}$ )

$$T_{\text{row}} = \frac{746}{37.5} \approx 19.89$$

The acquisition time (unit:  $\mu\text{s}$ )

$$T_{\text{acq}} = (\text{Height} + 38) * T_{\text{row}}$$

12) For MER-301-125U3M/C(-L) camera:

When the pixel format is Mono8 or BayerRG8, the row period (unit:  $\mu\text{s}$ )

$$T_{\text{row}} = \frac{190}{37.5} = 5.07$$

When the pixel format is Mono10 or BayerRG10, the row period (unit:  $\mu\text{s}$ )

$$T_{\text{row}} = \frac{380}{37.5} = 10.13$$

The acquisition time (unit:  $\mu\text{s}$ )

$$T_{\text{acq}} = (\text{Height} + 38) * T_{\text{row}}$$

13) For MER-302-56U3M/C(-L) camera:

Row period (unit:  $\mu\text{s}$ )

$$T_{\text{row}} = \frac{423}{37.5} = 11.28$$

The acquisition time (unit:  $\mu\text{s}$ )

$$T_{\text{acq}} = (\text{Height} + 32) * T_{\text{row}}$$

14) For MER-500-14U3M/C(-L) camera:

Row period (unit:  $\mu\text{s}$ )

$$T_{\text{row}} = 20832 * \max\left(\left(\frac{(\text{Width} + 1)}{2} + 450\right), 487\right) * 10^{-6}$$

The acquisition time (unit:  $\mu\text{s}$ )

$$T_{\text{acq}} = (\text{Height} + 19) * T_{\text{row}}$$

15) For MER-502-79U3M/C(-L) /MER-502-79U3M(-L) POL camera:

When the pixel format is Mono8 or BayerRG8, the row period (unit:  $\mu\text{s}$ )

$$T_{\text{row}} = \frac{227}{37.5} = 6.053$$

When the pixel format is Mono10 or BayerRG10, the row period (unit:  $\mu\text{s}$ )

$$T_{\text{row}} = \frac{454}{37.5} = 12.107$$

The acquisition time (unit:  $\mu\text{s}$ )

$$T_{\text{acq}} = (\text{Height} + 38) * T_{\text{row}}$$

16) For MER-503-36U3M/C(-L) camera:

Row period (unit:  $\mu\text{s}$ )

$$T_{\text{row}} = \frac{498}{37.5} = 13.28$$

The acquisition time (unit:  $\mu\text{s}$ )

$$T_{\text{acq}} = (\text{Height} + 32) * T_{\text{row}}$$

17) For MER-630-60U3M/C(-L) camera:

When the pixel format is Mono8 or BayerRG8, the row period (unit:  $\mu\text{s}$ )

$$T_{\text{row}} = \frac{420}{54} = 7.78$$

When the pixel format is Mono10 or BayerRG10, the row period (unit:  $\mu\text{s}$ )

$$T_{\text{row}} = \frac{420 * 2}{54} = 15.56$$

The acquisition time (unit:  $\mu\text{s}$ )

$$T_{\text{acq}} = (\text{Height} + 78) * T_{\text{row}}$$

18) For MER-1070-14U3M/C(-L) camera:

Row period (unit:  $\mu\text{s}$ )

$$T_{\text{row}} = 24.7$$

The acquisition time (unit:  $\mu\text{s}$ )

$$T_{\text{acq}} = (\text{Height} + 143) * T_{\text{row}}$$

19) For MER-1220-32U3M/C(-L) camera:

When the pixel format is BayerRG8, the row period (unit:  $\mu\text{s}$ )

$$T_{\text{row}} = \frac{720}{72} = 10$$

When the pixel format is BayerRG12, the row period (unit:  $\mu\text{s}$ )

$$T_{\text{row}} = \frac{720 * 2}{72} = 20$$

The acquisition time (unit:  $\mu\text{s}$ )

$$T_{\text{acq}} = (\text{Height} + 38) * T_{\text{row}}$$

20) For MER-1520-13U3C(-L) camera:

Row period (unit:  $\mu\text{s}$ )

$$T_{\text{row}} = \frac{246}{11} \approx 22.4$$

The acquisition time (unit:  $\mu\text{s}$ )

$$T_{\text{acq}} = (\text{Height} + 146) * T_{\text{row}}$$

21) For MER-1810-21U3C(-L) camera:

When the pixel format is BayerGR8, the row period (unit:  $\mu\text{s}$ )

$$T_{\text{row}} = \frac{5568}{55 * 8} = 12.655$$

When the pixel format is BayerGR12, the row period (unit:  $\mu\text{s}$ )

$$T_{\text{row}} = \frac{5568 * 2}{55 * 8} = 25.3$$

The acquisition time (unit:  $\mu\text{s}$ )

$$T_{\text{acq}} = (\text{Height} + 77) * T_{\text{row}}$$

22) For MER-2000-19U3M/C(-L) camera:

When the pixel format is BayerRG8, the row period (unit:  $\mu\text{s}$ )

$$T_{\text{row}} = \frac{900}{72} = 12.5$$

When the pixel format is BayerRG12, the row period (unit:  $\mu\text{s}$ )

$$T_{\text{row}} = \frac{900 * 2}{72} = 25$$

The acquisition time (unit:  $\mu\text{s}$ )

$$T_{\text{acq}} = (\text{Height} + 38) * T_{\text{row}}$$



## 9. Software Tool

### 9.1. Frame Rate Calculation Tool

B	C
Width	1280
Height	1024
DecimationHorizontal	1
DecimationVertical	1
ExposureTime (us)	10000
PixelFormat (8/10)	8
DeviceLinkThroughputLimit (Bps)	300000000
MaxUSBControllerThroughput (Bps)	380000000
AcquisitionFrameRateMode	off
AcquisitionFrameRate	210
<b>FPS</b>	<b>100.00</b>

Figure 9-1 Frame rate calculation tool

The frame rate calculation tool is currently provided in the form of Excel. When using it, firstly select the camera model in the table, and then achieve the expected frame rate by modifying the parameter of the camera. There are four major types of influencing factors, including image readout time (image width, image height, pixel format), exposure time, acquisition frame rate control, and device link throughput limit.

Table parameter explanation:

- 1) The Width and Height are the set ROI size.
- 2) For more details about BinningHorizontal, BinningVertical, DecimationHorizontal and DecimationVertical, please refer to [section 8.3.10](#) and [section 8.3.11](#). These four parameters affect the transmission time of the image data.
- 3) The ExposureTime is the exposure time when the camera acquires one frame of image.
- 4) The PixelFormat is the pixel format corresponding to the camera output image, including 8 bits, 10 bits or 12 bits.
- 5) The DeviceLinkThroughputLimit represents the maximum bandwidth of the image transmitted by the camera.
- 6) The MaxUSBControllerThroughputLimit represents the recommended maximum transmission bandwidth of the camera. If this value is exceeded, frame losing may occur.
- 7) The AcquisitionFrameRate represents the maximum value of the frame rate control when the AcquisitionFrameRateMode is set to on, and whether the maximum value can be reached depends on whether the camera is affected by other acquisition parameters.

- 8) AcquisitionFrameRateMode indicates whether frame rate control is enabled, On means frame rate control is enabled, and Off means frame rate control is disabled. When frame rate control is enabled, the camera acquires images at a frame rate no higher than the AcquisitionFrameRate. When frame rate control is disabled, the camera acquires images without being affected by the AcquisitionFrameRate.

When using the frame rate calculation tool, please fill in the above information of the camera into the corresponding table. When the filled value exceeds the range or does not conform to the rules, the calculation tool will report an error. Please modify and fill in the value again according to the prompt information. When all parameters are correctly filled in, the FPS shown in the last column of the table is the theoretical frame rate currently acquired by the camera, and usually the error between this value and the actual frame rate acquired by the camera is no more than 1%.

## 10. FAQ

No.	General Question	Answer
1	On the unactivated Windows7 64bit system, the installation of Galaxy SDK has been successfully, but open the demo program failed.	1) Activate Windows7 64bit system, uninstall the package, restart the system, reinstall the package and reopen the demo program.
2	The cameras cannot be enumerated.	1) Please check whether the LED is green, and check whether the USB cable is connected properly, re-enumerate after re-plugging the camera. 2) Please check whether the driver of connected controller works well, reinstall the controller driver and enumerate repeatedly. 3) Please check whether the driver of host controller works well, and whether the camera displays as "USB3 Vision Digital Camera", if not, try to reinstall the setup driver.
3	Fail to open device, it shows "Load XML failed".	1) Contact with the technical support to obtain upgrade program, and then upgrade your cameras.
4	Fail to open device, it shows that "The device has been opened".	1) Please close the software which has opened the camera.
5	Fail to open device, it shows that "This device can only be operated on an USB3.0 Port".	1) Please check whether the camera is connected to USB2.0 port or USB2.0 HUB. Be sure to connect the camera to USB3.0 port.
6	No images after acquisition start.	1) Please load the default parameter set, reopen the demo, execute the command AcquisitionStart again, and then check the frame rate. 2) Open the demo, switch to stream features page, and decrease the number of StreamTransferNumberUrb to 10. Then try to execute the command AcquisitionStart again and check the frame rate. 3) Open the demo, switch to stream features page, check the statistic information, and check if any packet has been received. If there are some incomplete frames, please refer to <a href="#">section 2.2</a> .
7	The frame rate is not up to the nominal value.	1) Change another PC with high performance. 2) It's recommended to use Intel host controller. 3) Be sure the main board support PCI-E2.0 or above. 4) If you have any other questions, please contact us.
8	Lose frames seriously in a multiple cameras' application.	1) The bandwidth of the camera is more than the bandwidth of the host controller. You can decrease the bandwidth through the DeviceLinkThroughputLimit function. 2) Connect the camera to the host controller separately.

9	Camera crashes on Advantech AIIIS-1440 IPC.	1) Be sure the driver version of AMD USB controller is later than 2.20.
---	---	---

## 11. Revision History

No.	Version	Changes	Date
1	V1.0.0	Initial release	2016-05-25
2	V1.0.1	Update to MER-133-54U3M	2016-07-04
3	V1.0.2	Update to MER-301-125U3x	2016-07-15
4	V1.0.3	Add SNR and definition to MER-133-54U3M	2016-07-28
5	V1.0.4	Add SNR and definition to MER-502-79U3x	2016-08-24
6	V1.0.5	Update to MER-1810-21U3C	2016-08-30
7	V1.0.6	Add SNR and definition to MER-1810-21U3C	2016-10-12
8	V1.0.7	Update to MER-031-860U3M NIR, MER-050-560U3M NIR, MER-131-210U3M NIR	2016-11-08
9	V1.0.8	Update to MER-503-36U3x	2016-11-11
10	V1.0.9	Update section 1.2 and 1.3	2016-12-02
11	V1.0.10	Update MER-XXX-XXXU3M NIR-L to MER-XXX-XXXU3M-L NIR	2016-12-26
12	V1.0.11	Update table 4-2, Update SNR and definition NIR camera, MER-1810-21U3C, MER-301-125U3x	2017-01-12
13	V1.0.12	Update FAQ	2017-04-01
14	V1.0.13	Add section 3.2, update table 1-16 and table 1-17, update to MER-133-54U3x	2017-04-05
15	V1.0.14	Change MER-503-36U3x ADC bit width to 12bit	2017-05-11
16	V1.0.15	Update SNR and definition to MER-133-54U3C and MER-133-54U3M	2017-05-25
17	V1.0.16	Update to MER-302-56U3x, except Gain SNR Definition Add GPIO delay time and opto-isolated delay time of the MER-134-93U3x Rename MER-133-54U3m and MER-134-93U3m to MER-133-54U3x and MER-134-93U3x	2017-06-15
18	V1.0.17	Unify Sensor Type	2017-06-21

19	V1.0.18	Revise MER-1520-13U3C frame rate	2017-06-22
20	V1.0.19	Update section 1.5 Update section 2	2017-07-27
21	V1.0.20	Modify some descriptive languages and some minor bugs.	2017-09-05
22	V1.0.21	Update SNR and definition to MER-302-56U3x	2017-09-19
23	V1.0.22	Update to MER-051-120U3x	2017-10-11
24	V1.0.23	Modify sales Tel., delete MER-132-30U3x, specify sensor type for MER-132-43U3x	2017-10-24
25	V1.0.24	Update SNR and definition to MER-134-93U3C and MER-134-93U3M	2017-11-08
26	V1.0.25	Update definition to MER-1810-21U3C	2017-11-10
27	V1.0.26	Update gain to MER-051-120U3x	2017-12-22
28	V1.0.27	Add MER-630-60U3x	2017-12-29
29	V1.0.28	Update SNR to MER-051-120U3x Change the company's logo	2018-01-25
30	V1.0.29	Change the E-mail Update definition to MER-051-120U3C and MER-051-120U3M	2018-02-26
31	V1.0.30	Modify section 2.2.2.2 , since MER-630-60U3x doesn't support Multi-ROI	2018-03-05
32	V1.0.31	Fix error for table 1-33 Update SNR and definition to MER-630-60U3x	2018-03-19
33	V1.0.32	Fix error for table 2-2 Add MER-2000-19U3x	2018-04-18
34	V1.0.33	Fix error for table 1-32 and table 1-33	2018-04-18
35	V1.0.34	Fix error for section 1.3.18	2018-04-18
36	V1.0.35	Change the frame rate of MER-200-19U3x to 19.6fps	2018-04-25
37	V1.0.36	Update SNR and definition to MER-2000-19U3x	2018-05-10
38	V1.0.37	Add FCC Certifications	2018-05-23

39	V1.0.38	Add MER-041-436U3x	2018-08-12
40	V1.0.39	Add MER-502-79U3M POL	2018-08-30
41	V1.0.40	Update SNR and definition to MER-502-79U3M POL Update SNR and definition to MER-041-436U3x	2018-09-07
42	V1.0.41	Update Figure1- 25 to MER-502-79U3M POL Add MER-160-227U3x	2018-09-21
43	V1.0.42	Update SNR and definition to MER-160-227U3x Update SNR and definition to MER-301-125U3M	2018-10-26
44	V1.0.43	Add MER-1220-32U3x Update Figure1- 1 to MER-041-436U3C Update SNR to part of the camera	2018-12-27
45	V1.0.44	Update 3.3 IO Port	2019-01-04
46	V1.0.45	Update SNR for MER-051-120U3C	2019-01-08
47	V1.0.46	Update SNR and definition for MER-1220-32U3x	2019-01-21
48	V1.0.47	Update definition for MER-133-54U3M Update definition for MER-132-43U3x	2019-02-18
49	V1.0.48	Update definition for these cameras: MER-131-210U3C, MER-134-93U3C, MER-230-168U3M, MER-231-41U3M, MER-302-56U3M, MER-500-14U3C, MER-502-79U3M/C, MER-503-36U3M/C, MER-1070-14U3C, MER_1810-21U3C, MER-2000-19U3M Update SNR for MER-2000-19U3M	2019-02-26
50	V1.0.49	Update definition for MER-302-56U3M	2019-03-01
51	V1.0.50	Update definition for MER-051-120U3M	2019-03-20
52	V1.0.51	Update definition for MER-230-168U3x	2019-04-30
53	V1.0.52	Adjust the structure Update definition for new sections Modify power consumption	2019-10-22
54	V1.0.53	Add the spectral response of MER-160-227U3x	2019-10-31
55	V1.0.54	Modify Figure 1-1 and Figure 7-4 Rename camera models, for example, rename MER-041-436U3x to MER-041-436U3M/C(-L)	2020-03-09

## 12. Contact Us

### 12.1. Contact Sales

If you need to order products or inquire product information, please contact our sales:

1) Beijing Headquarters

Tel: 010-82828878

Fax: 010-82563343

Email: [isales@deheng-imaging.com](mailto:isales@deheng-imaging.com)

2) Shanghai Office

Tel: 021-35312826

Fax: 021-65201839-128

Email: [shanghai@daheng-imaging.com](mailto:shanghai@daheng-imaging.com)

3) Shenzhen Office

Tel: 0755-83479565

Fax: 0755-82044020

E-mail: [shenzhen@daheng-imaging.com](mailto:shenzhen@daheng-imaging.com)

4) Wuhan Office

Tel: 027-87223690

Fax: 027-87223690

Email: [wuhan@daheng-imaging.com](mailto:wuhan@daheng-imaging.com)

5) Chengdu Office

Tel: 028-63167707

Fax: 028-63167707

E-mail: [chengdu@daheng-imaging.com](mailto:chengdu@daheng-imaging.com)

6) Xi'an Office

Tel: 029-84501012

Fax: 029-89588451



Email: [xian@daheng-imaging.com](mailto:xian@daheng-imaging.com)

## 12.2. Contact Support

If you have any questions in using DAHENG IMAGING products, please contact the experts on our support team:

Tel: 400-999-7595

Email: [isupport@daheng-imaging.com](mailto:isupport@daheng-imaging.com)